

Assembly Instructions

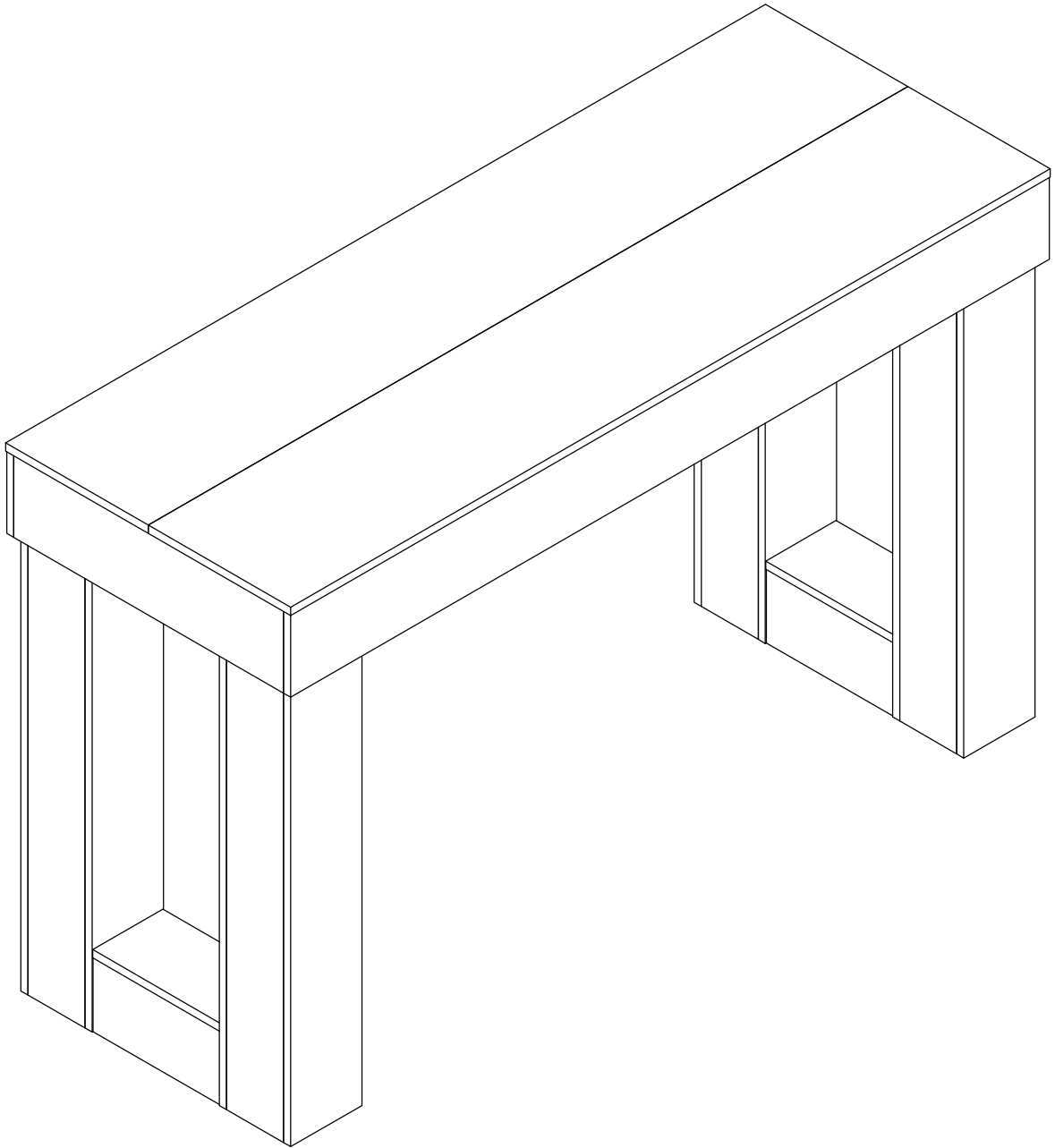

Bar Table

Model No.
HOGA-RY0324

Contact Us

We're here to help you.

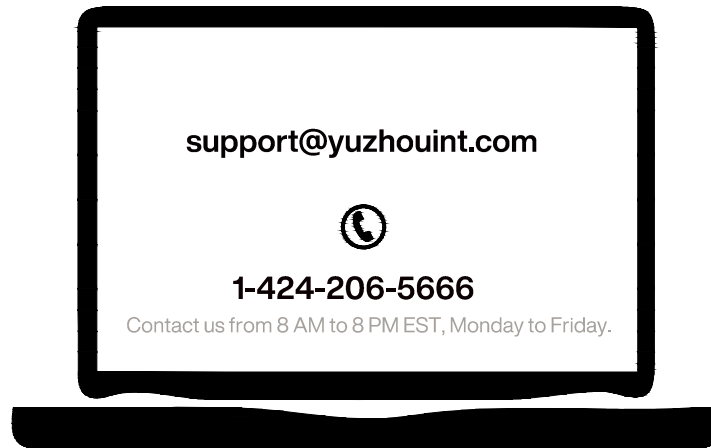

Your satisfaction is our top priority. If you encounter any issues with this product, such as missing or damaged parts, we're here to help. Please retain the original packaging and take photos of the packaging and the product, then contact us as soon as possible.

Warm Tips

1. Carefully read these instructions and keep them for future reference.
2. Check the parts list and confirm everything's there before starting assembly.
3. When assembling, put all parts on a soft, smooth surface like a carpet to avoid scratches.
4. Don't fully tighten screws until all parts are confirmed in place to avoid misalignment.

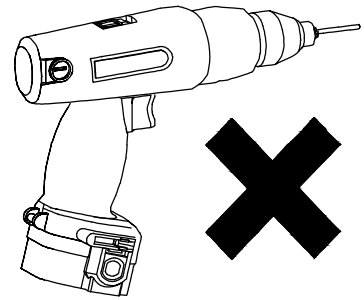
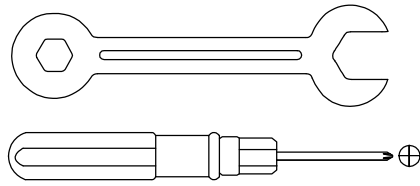
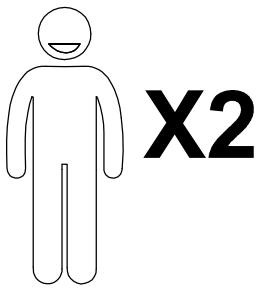

We recommend using hand tools for assembly.

If an electric screwdriver is used, reduce power and torque to avoid damage to the product.

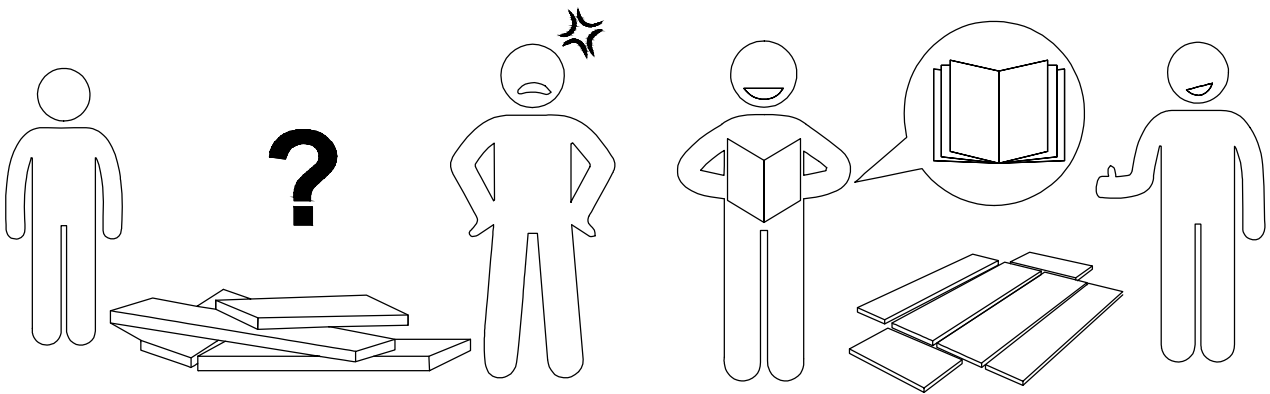

AVOID SCRATCHES

In order to avoid scratching, this furniture should be assembled on a soft surface, such as a rug.

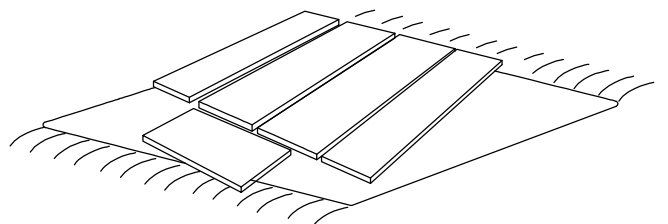
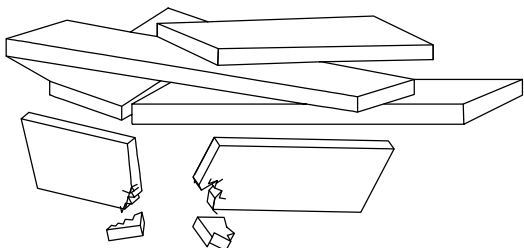

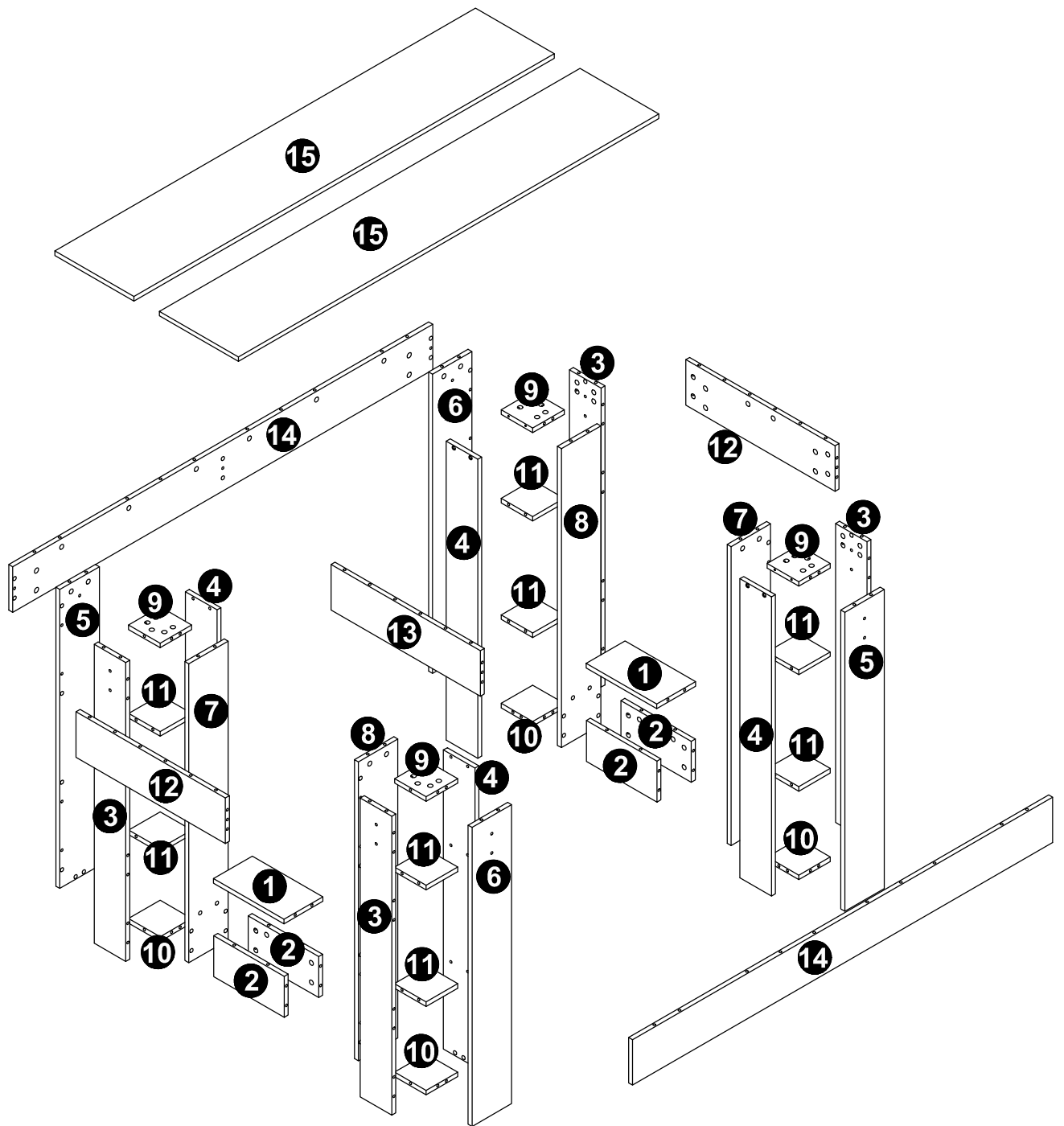







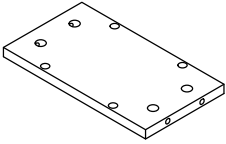
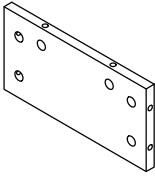

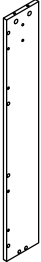

⚠ Caution

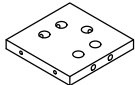
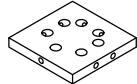
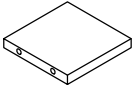
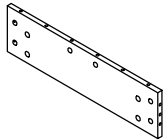
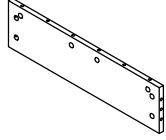
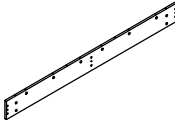
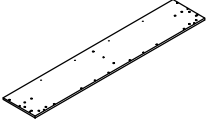

Make sure all parts are included. Most board parts are labeled or stamped on the raw edge. Contact us for a free replacement if you encounter any damaged or missing parts.

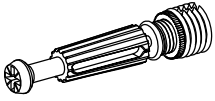
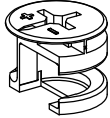
Parts List

<p>1</p>  <p>2 pcs</p>	<p>2</p>  <p>4 pcs</p>	<p>3</p>  <p>4 pcs</p>	<p>4</p>  <p>4 pcs</p>	<p>5</p>  <p>2 pcs</p>
<p>6</p>  <p>2 pcs</p>	<p>7</p>  <p>2 pcs</p>	<p>8</p>  <p>2 pcs</p>	<p>9</p>  <p>4 pcs</p>	<p>10</p>  <p>4 pcs</p>
<p>11</p>  <p>8 pcs</p>	<p>12</p>  <p>2 pcs</p>	<p>13</p>  <p>1 pc</p>	<p>14</p>  <p>2 pcs</p>	<p>15</p>  <p>2 pcs</p>

Hardware List

A	B	C	D	E	F
 <p>Ø6x40mm</p> <p>168 pcs</p>	 <p>Ø15x12mm</p> <p>168 pcs</p>	 <p>Ø7x38mm</p> <p>8 pcs</p>	 <p>M4x58mm</p> <p>1 pc</p>	 <p>M6x25mm</p> <p>16 pcs</p>	 <p>Ø8x30mm</p> <p>88 pcs</p>

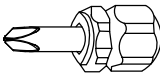
G	H	I	J
 <p>Ø3.5x14mm</p> <p>8 pcs</p>	 <p>76x14mm</p> <p>4 pcs</p>	 <p>Ø20mm</p> <p>48 pcs</p>	 <p>1 pc</p>

Installation of Cams and Pins

Step 1-2: Align the plastic part with the mounting hole and press it in. If you can't press it in, loosen the screw counter clockwise or completely remove the screw from the plastic part and try again.
Step 3-4: After pressing the plastic part into place, use a screwdriver to tighten the screw clockwise.

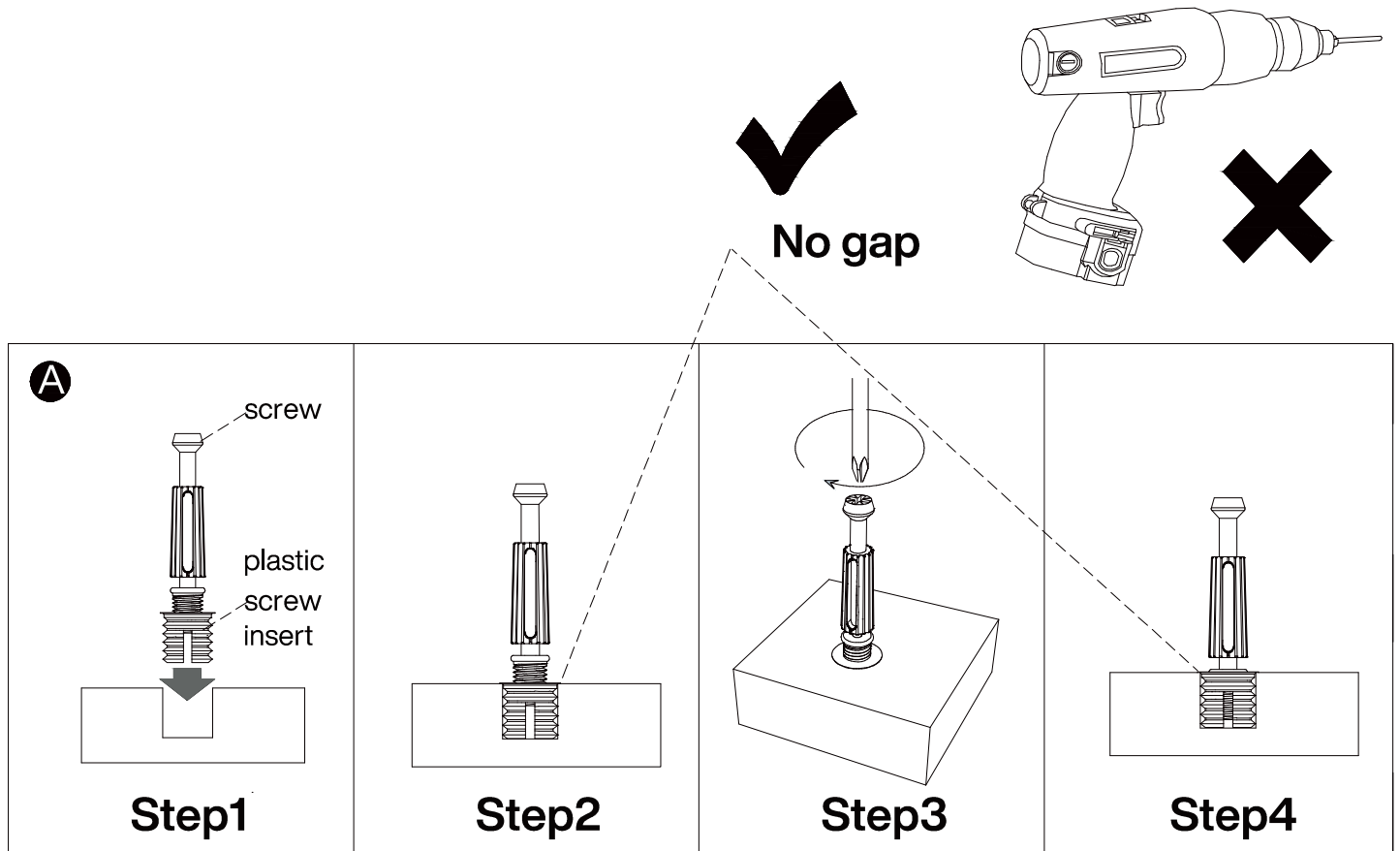

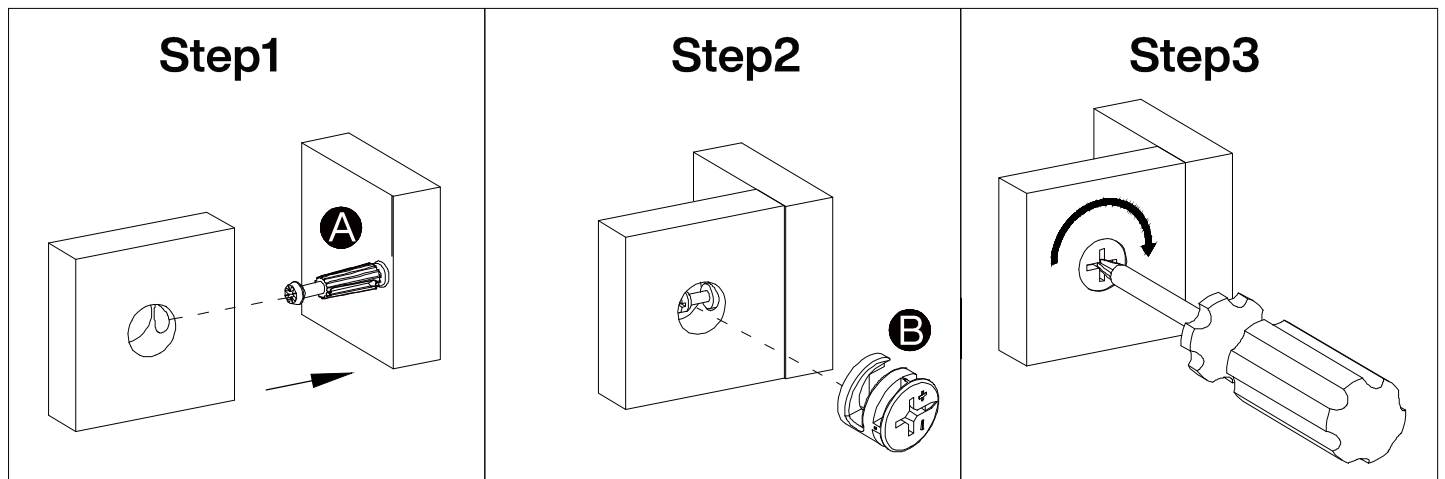

Screw the pin into the hole. Set the cams correctly by aligning the head of the cams with the lock pins. Lock the cam by turning the cam head with a screwdriver until it is tightened. Please do not use an electric screwdriver to assemble the unit.

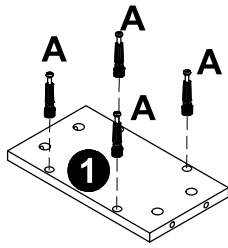

1

x2



A	B
	
Ø6x40mm	Ø15x12mm
8 pcs	8 pcs

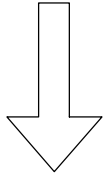

x2

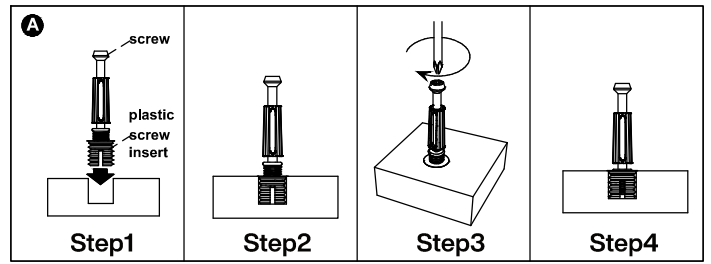
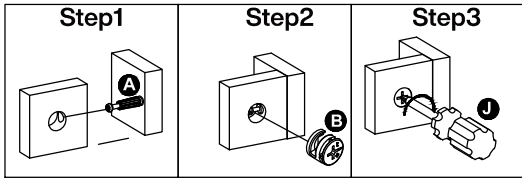
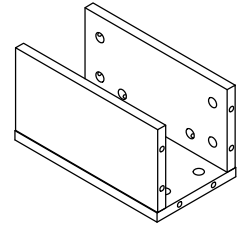
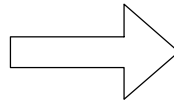
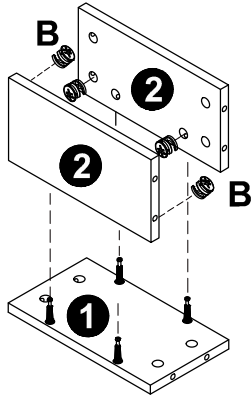

2

x2

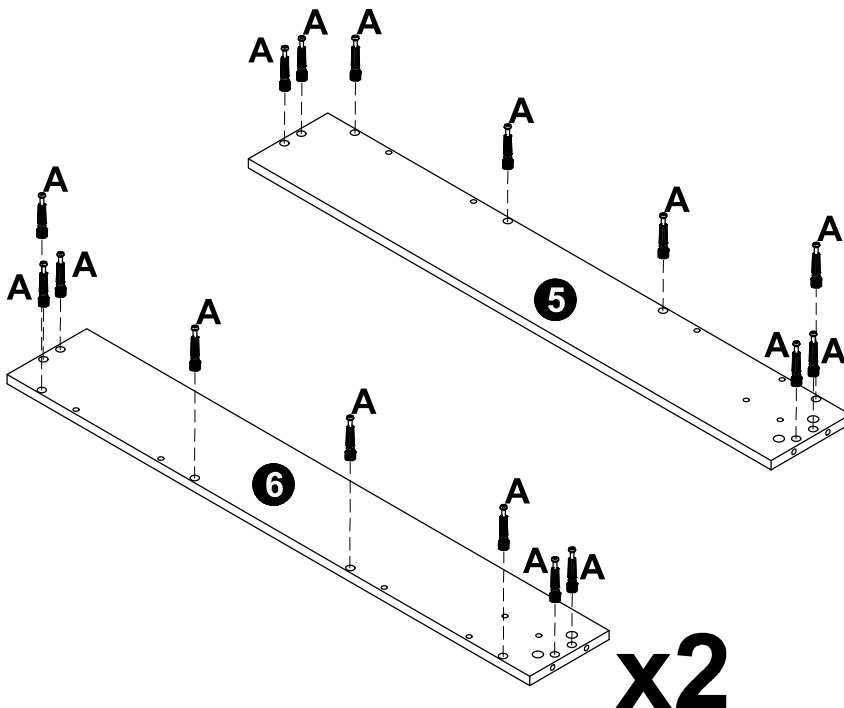

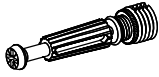
A

Ø6x40mm
32 pcs

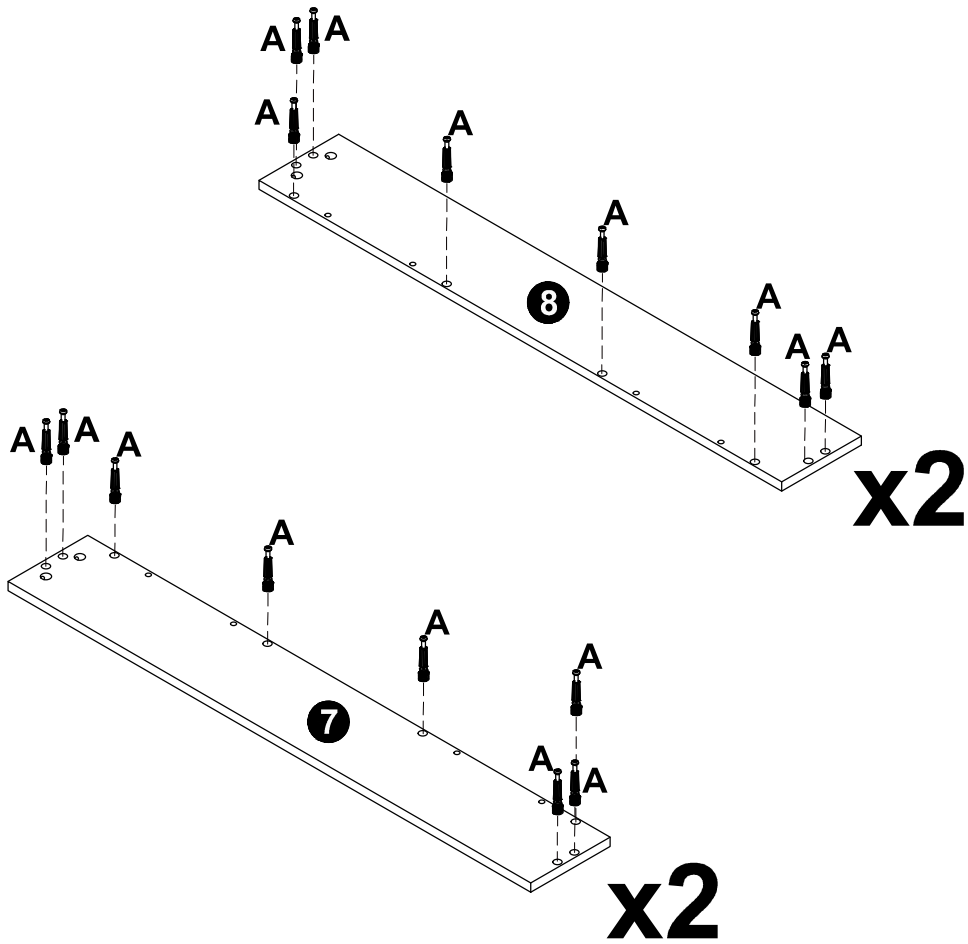

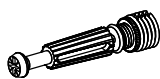
3

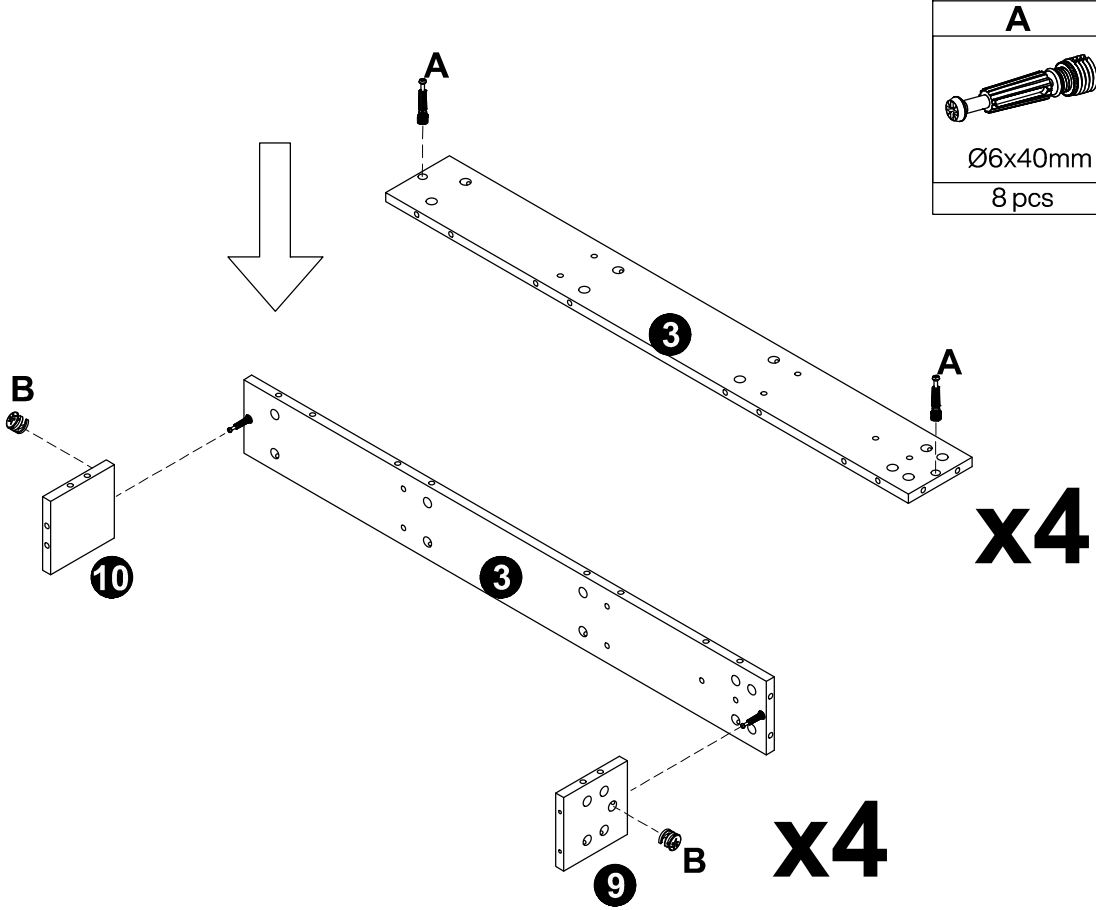

A

Ø6x40mm
32 pcs



4

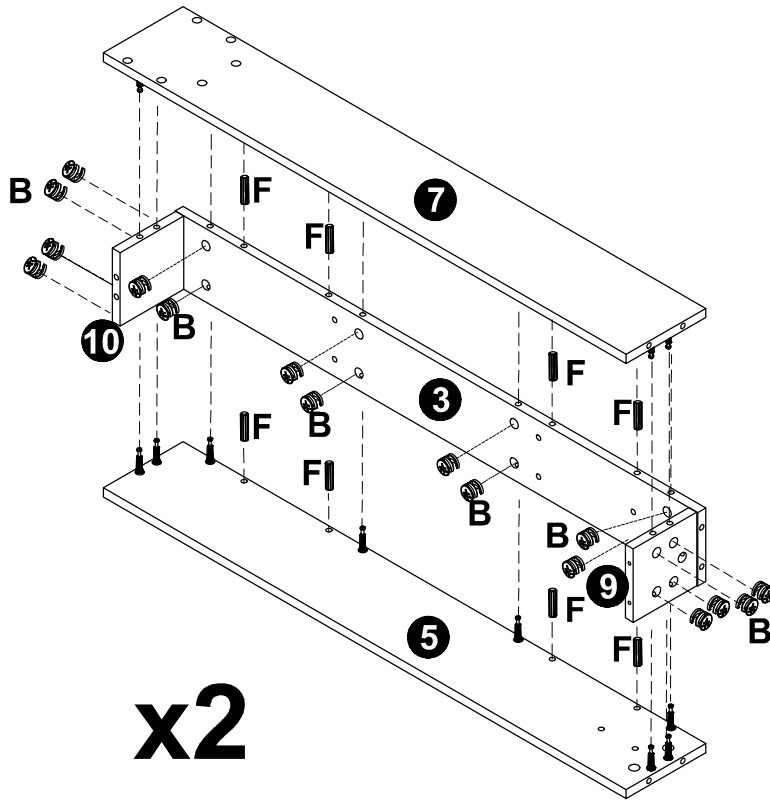

A	B
	
Ø6x40mm	Ø15x12mm
8 pcs	8 pcs

5



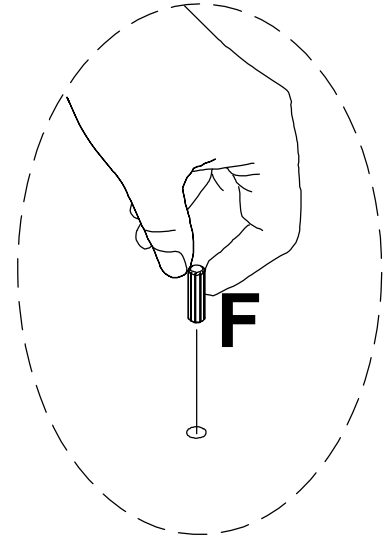

B	F
	
Ø15x12mm	Ø8x30mm
32 pcs	16 pcs

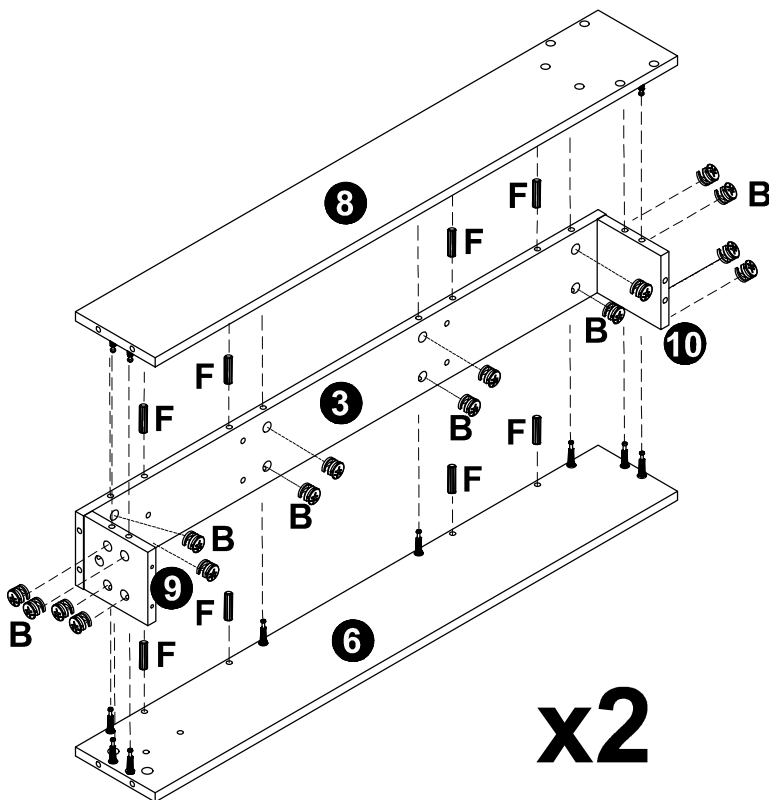

6



B	F
	
Ø15x12mm	Ø8x30mm
32 pcs	16 pcs

7

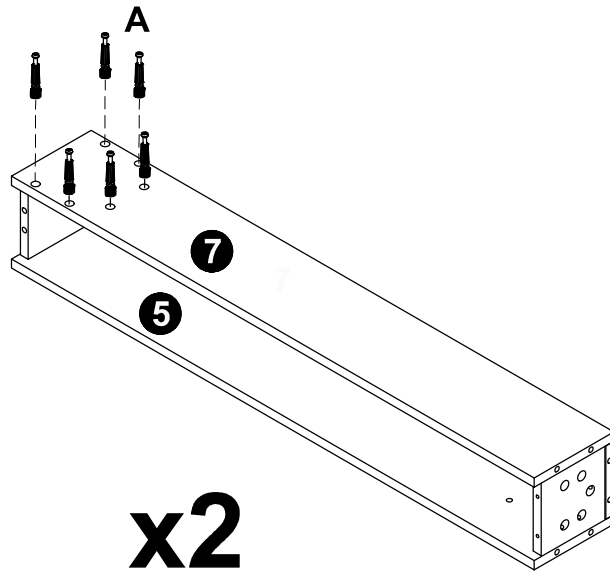

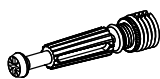
A

Ø6x40mm
12 pcs

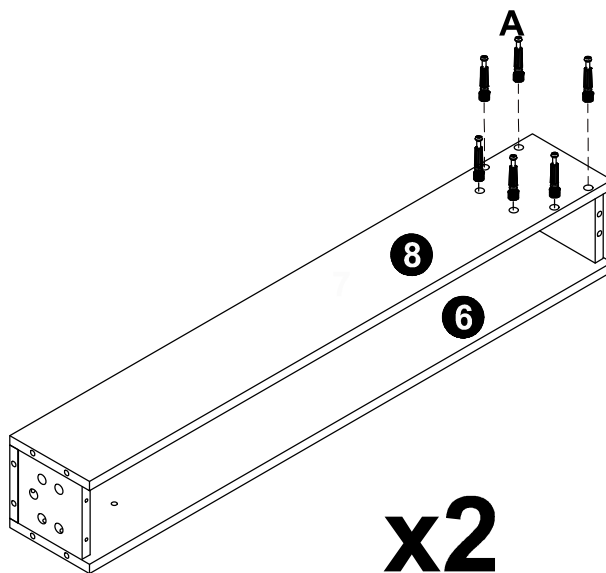
8

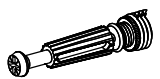

A

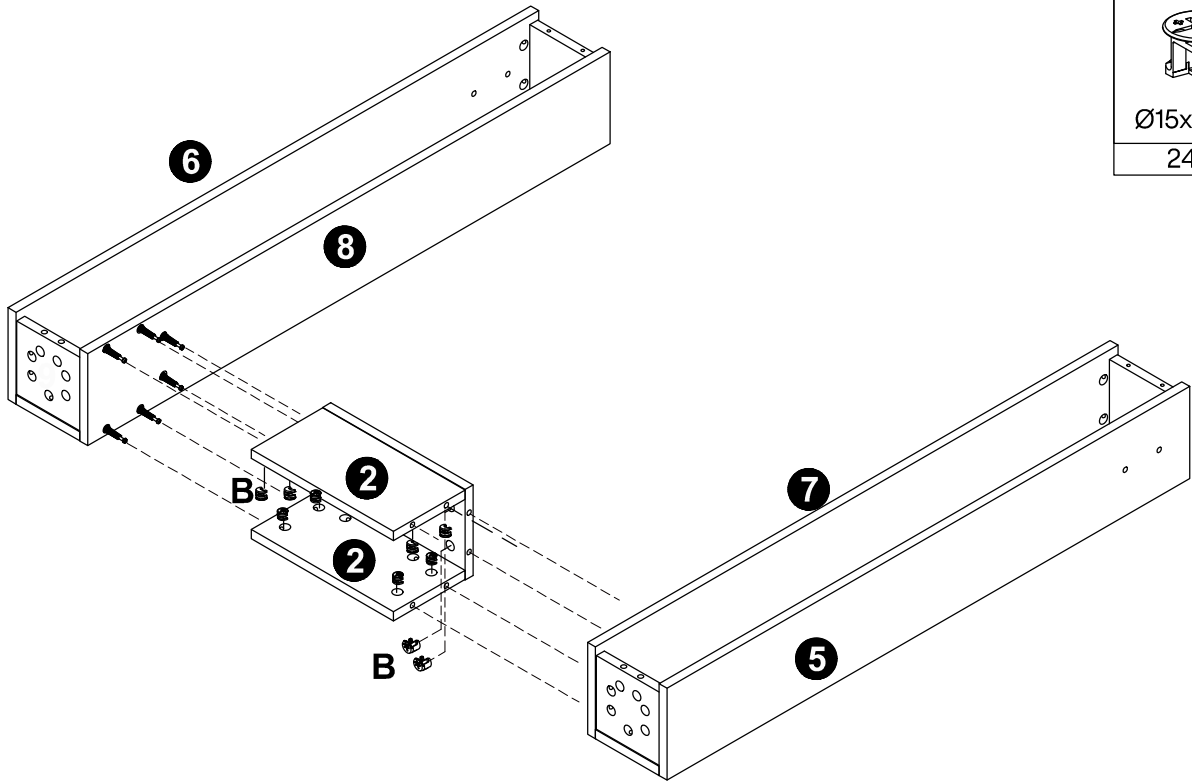
Ø6x40mm
12 pcs

9

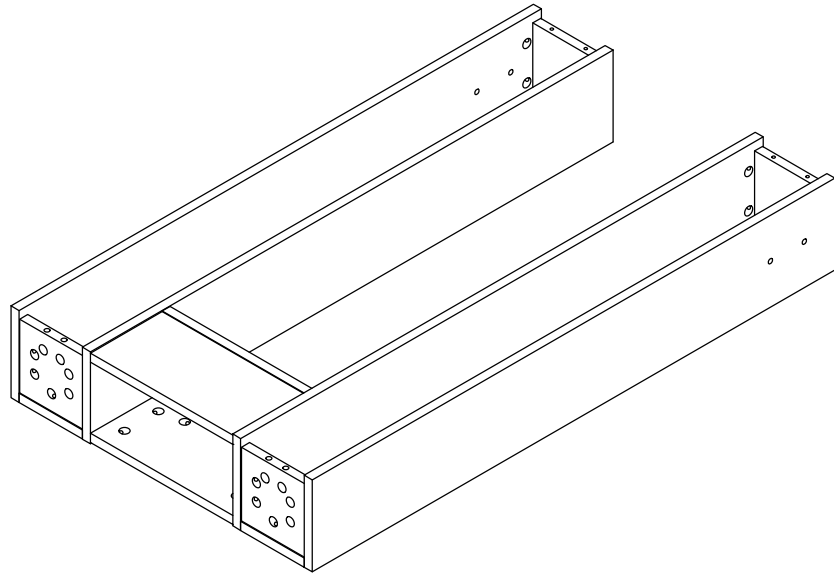
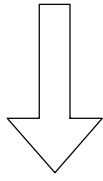

B

Ø15x12mm
24 pcs

x2

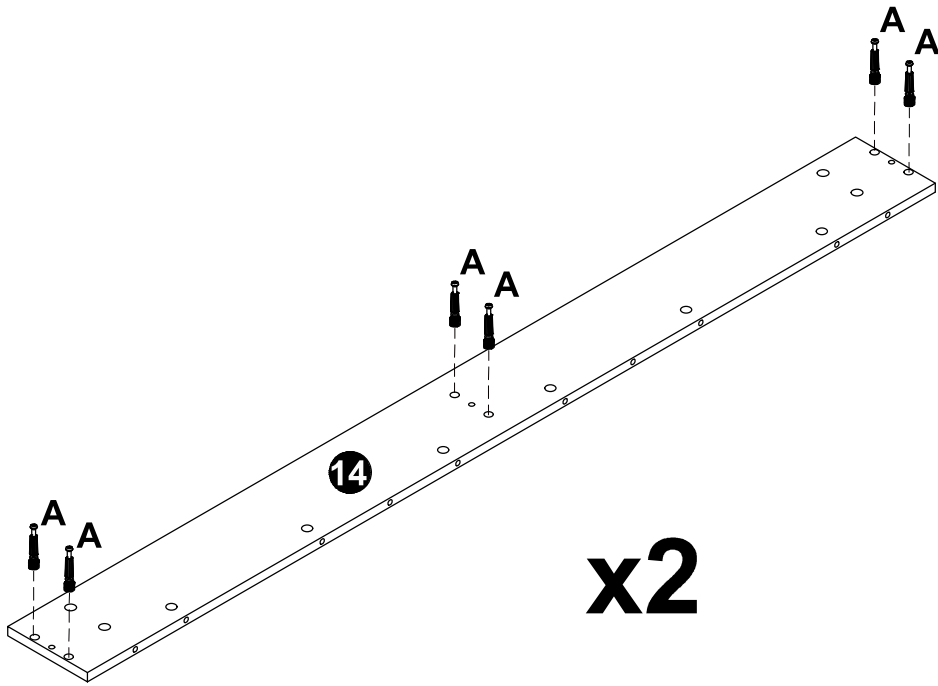

x2

10



A

Ø6x40mm
12 pcs

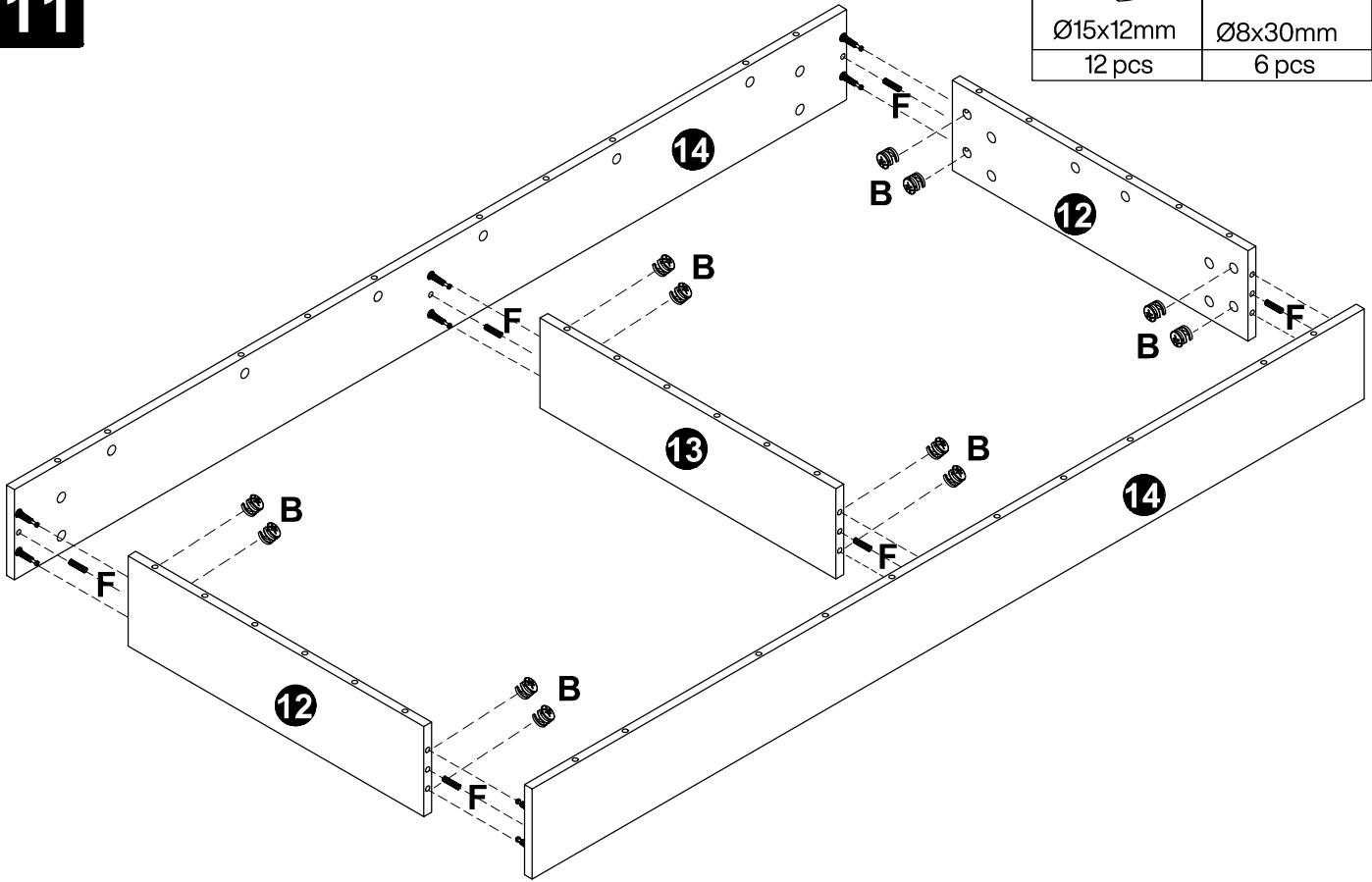
11

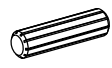

B	F
	
Ø15x12mm	Ø8x30mm
12 pcs	6 pcs

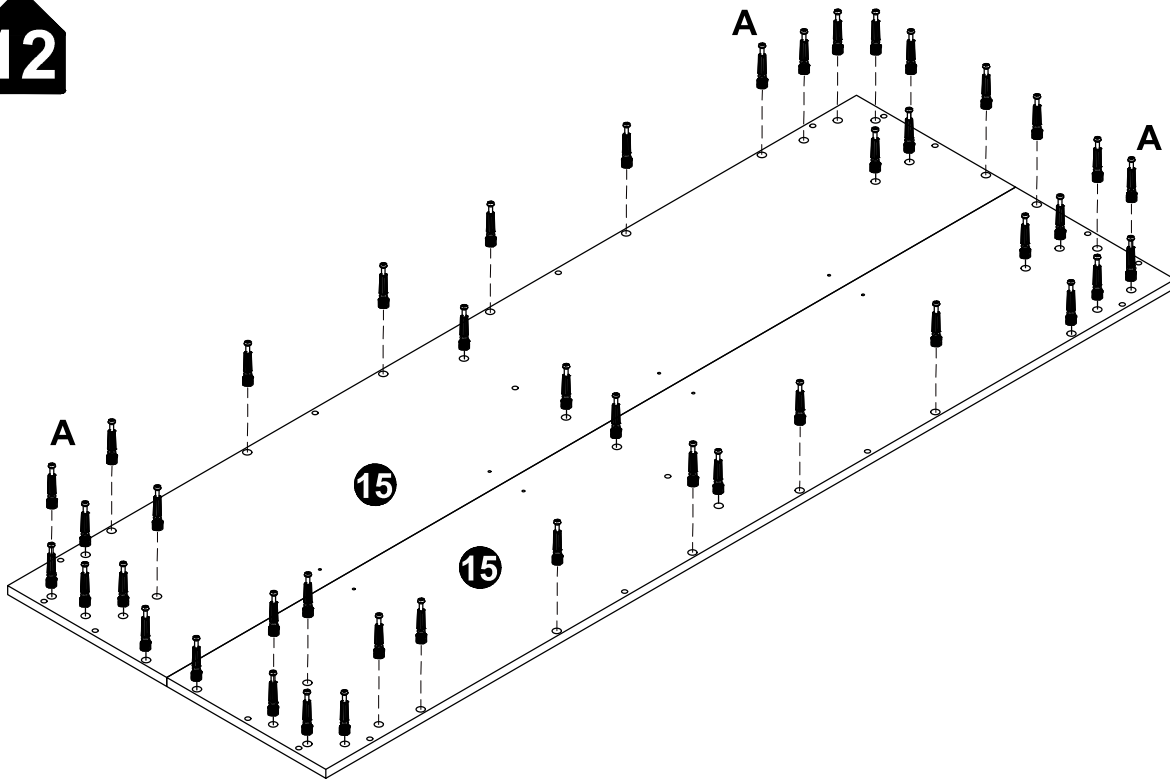
12



A

Ø6x40mm
44 pcs

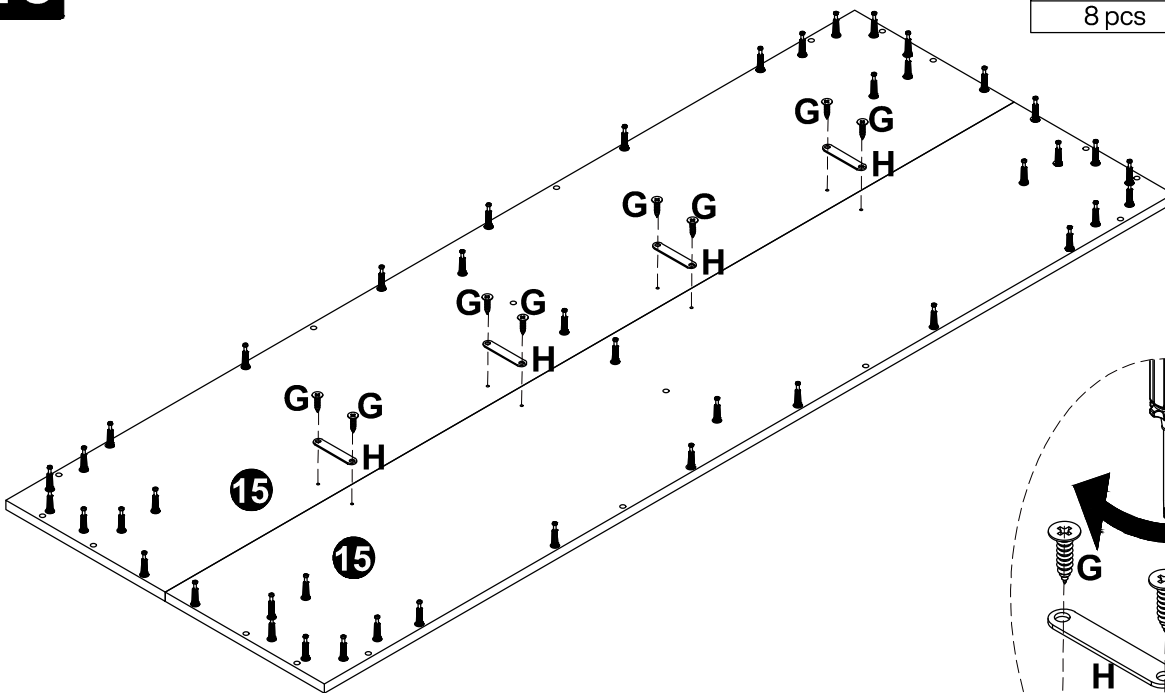

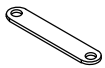
13

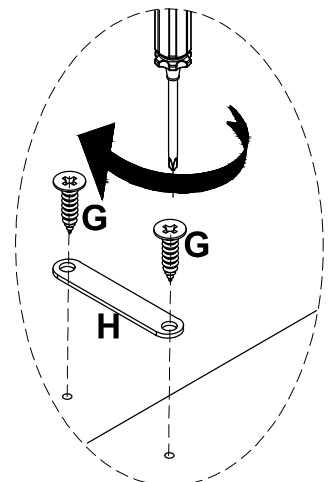

G	H
	
Ø3.5x14mm	76x14mm
8 pcs	4 pcs



14

B	F
	
Ø15x12mm 20 pcs	Ø8x30mm 18 pcs

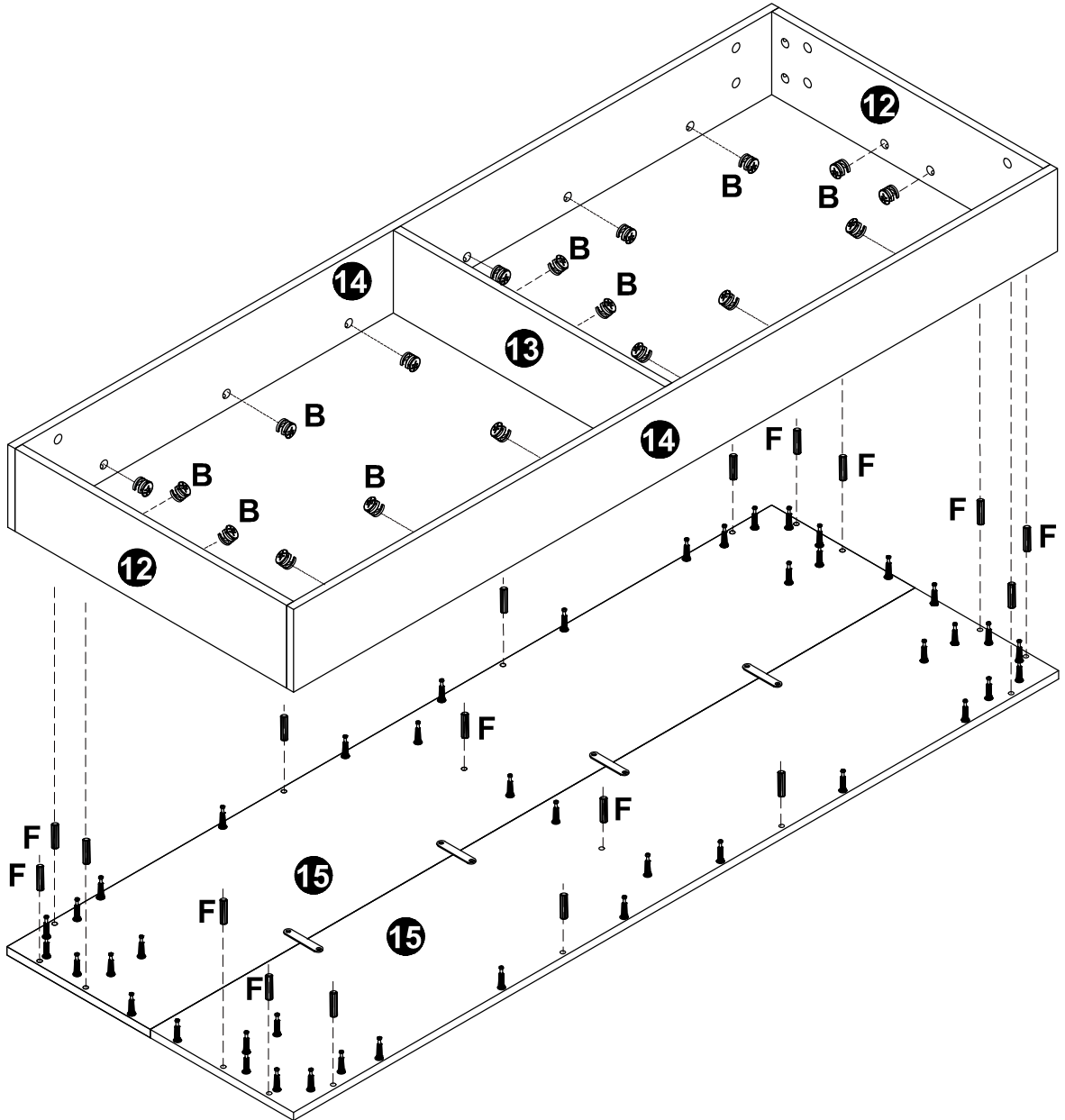

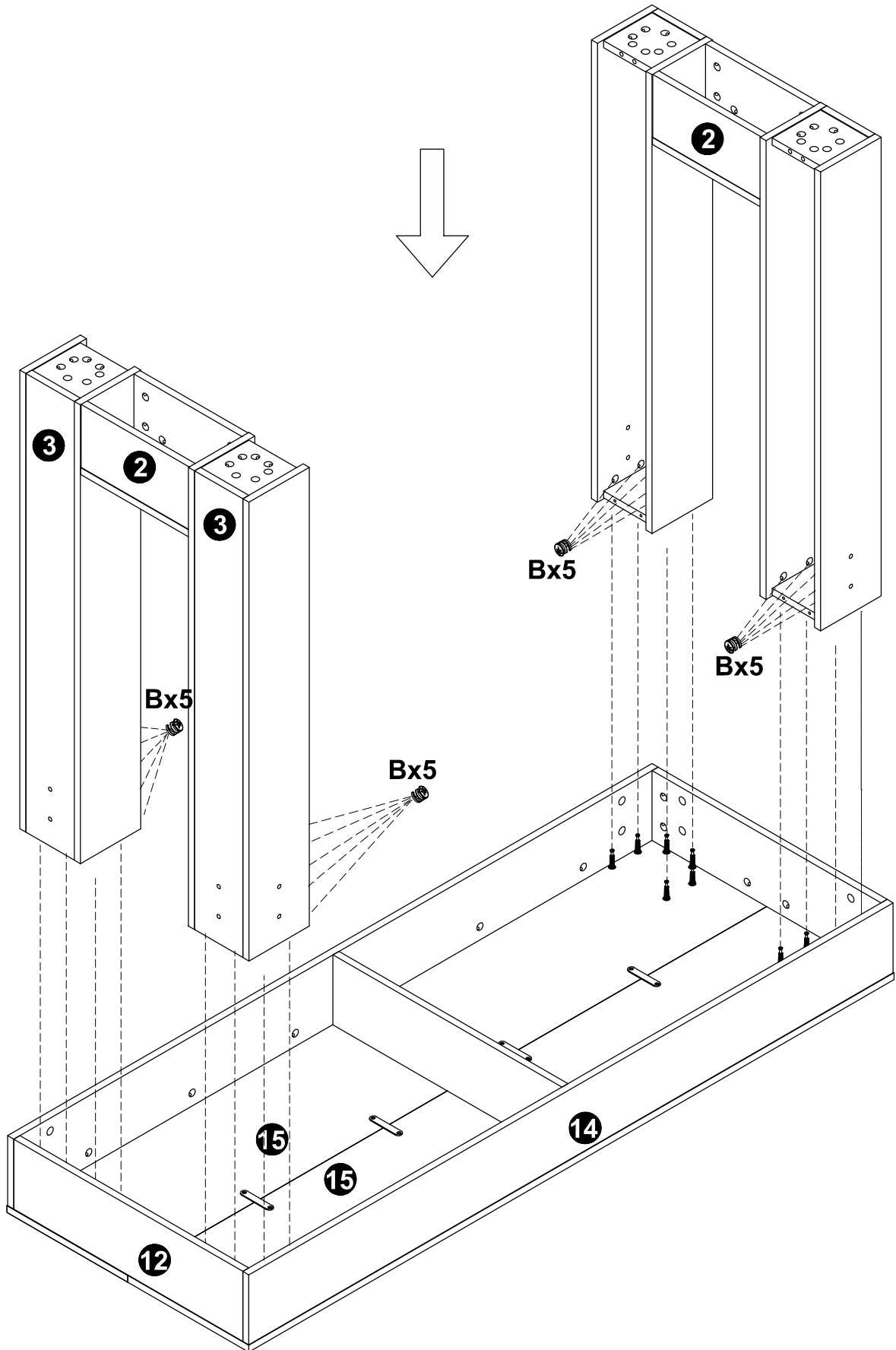

15

B

Ø15x12mm
24 pcs

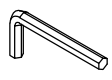

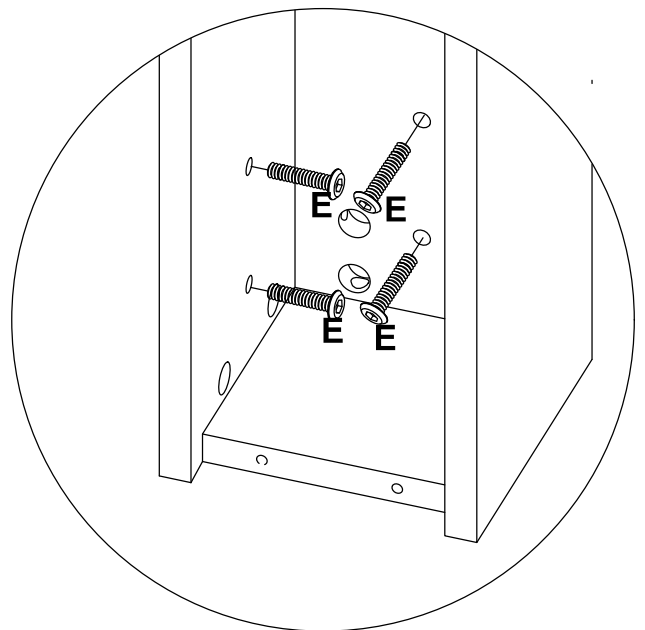
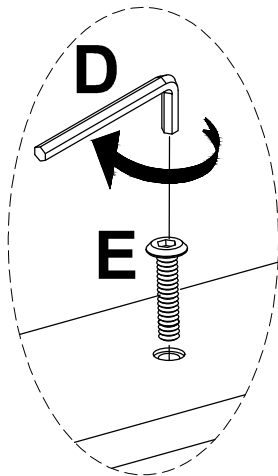
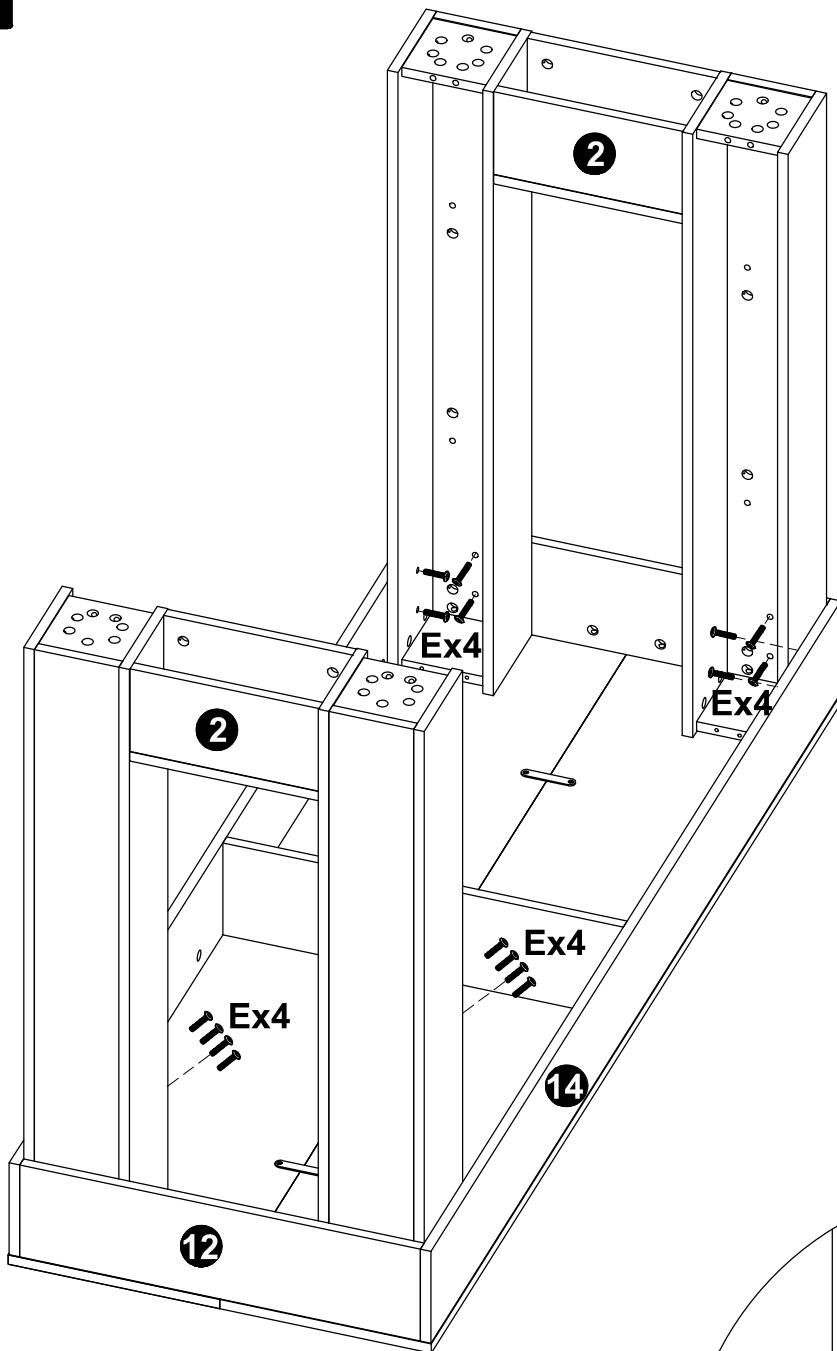

16

D	E
	
M4x58mm	M6x25mm
1 pc	16 pcs

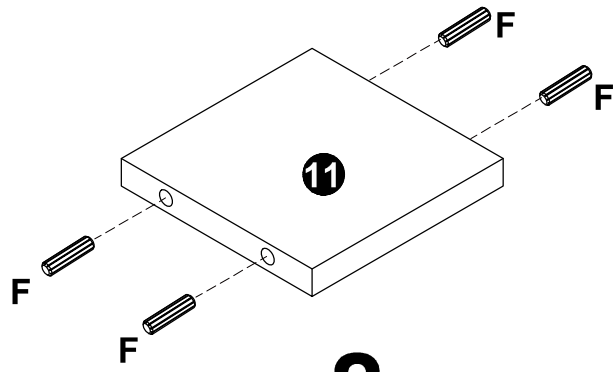

17



F

Ø8x30mm
32 pcs

x8

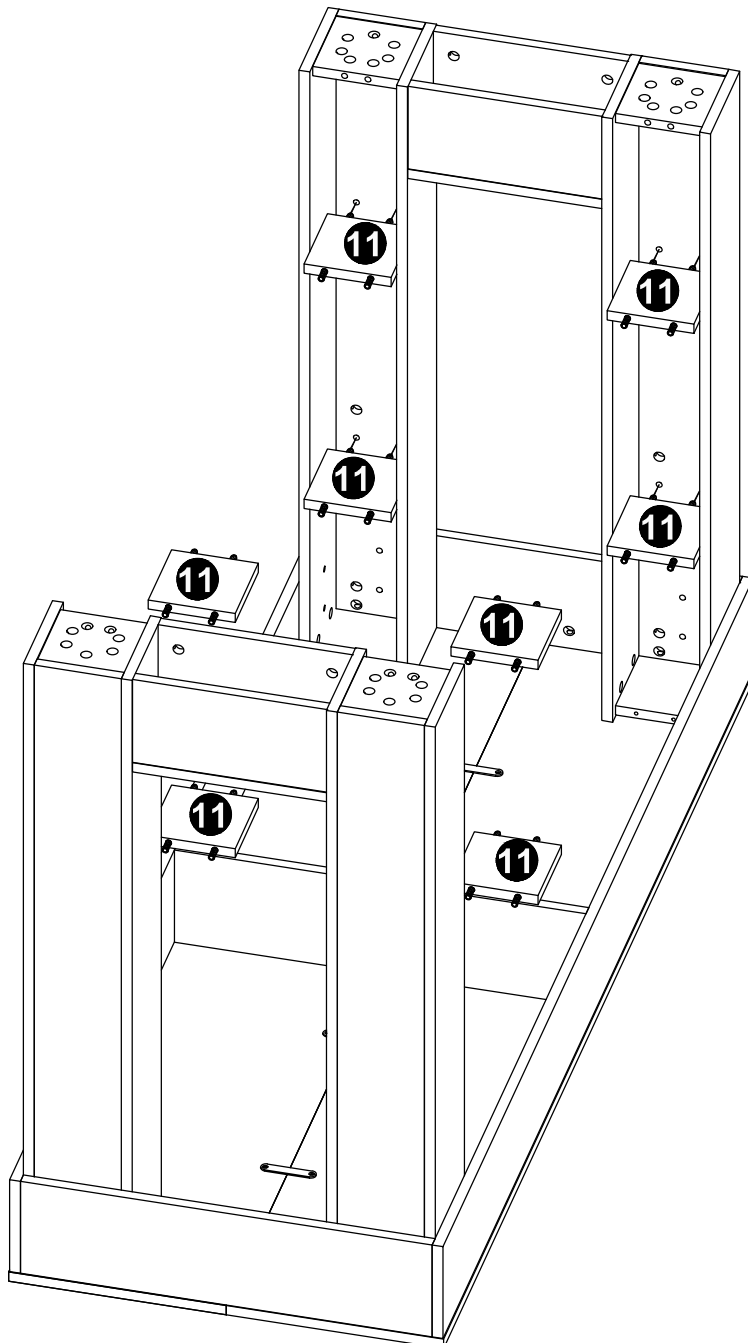
18



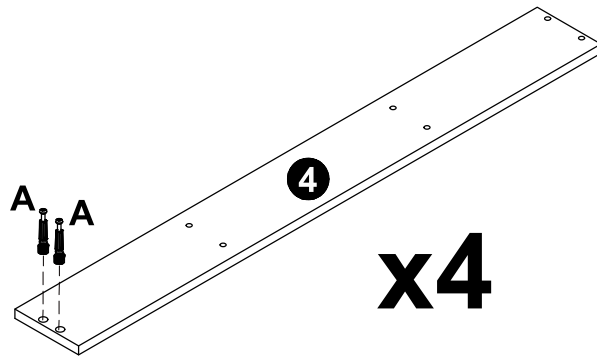

19

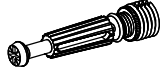

A

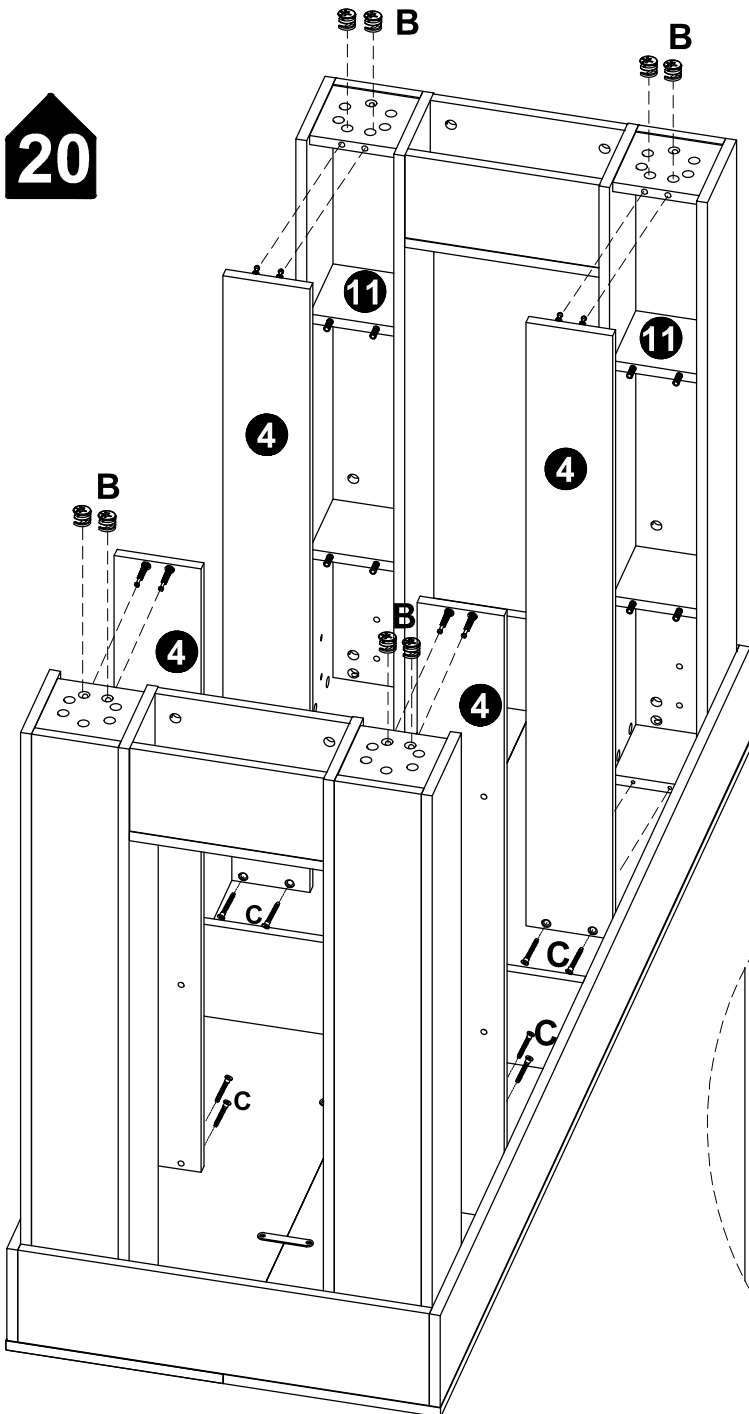
Ø6x40mm
8 pcs

20

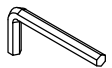

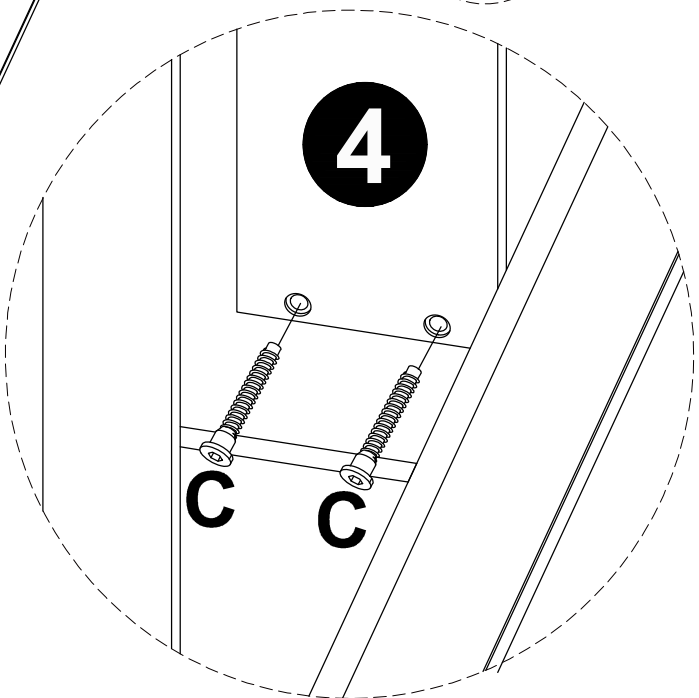
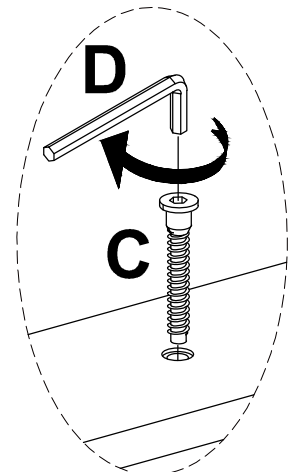
B	C	D
		
Ø15x12mm	Ø7x38mm	M4x58mm
8 pcs	8 pcs	1 pc



21

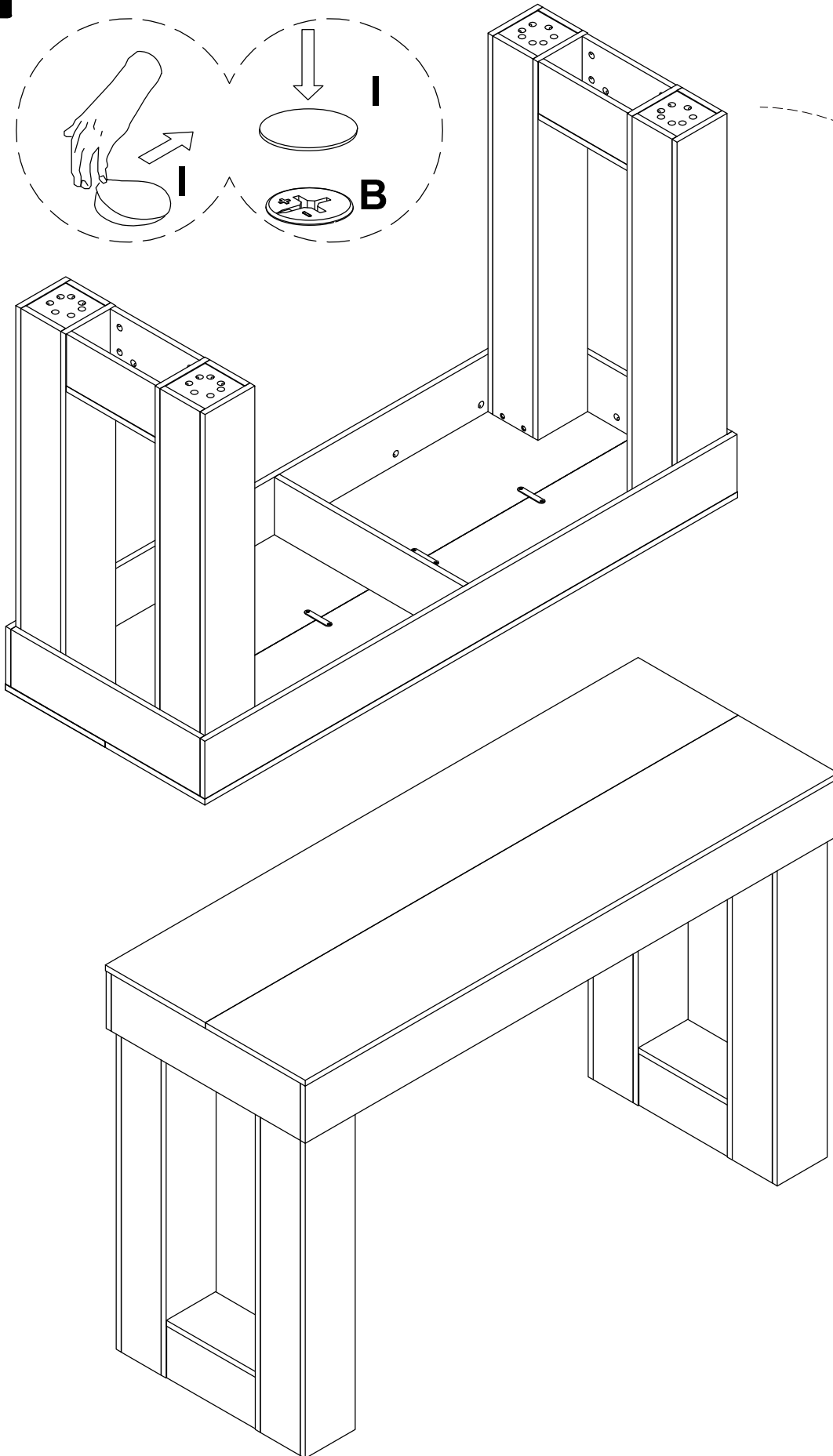
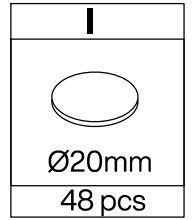
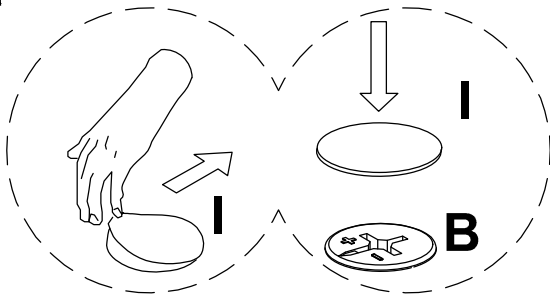

Thank you for your support!

