

Assembly Instructions

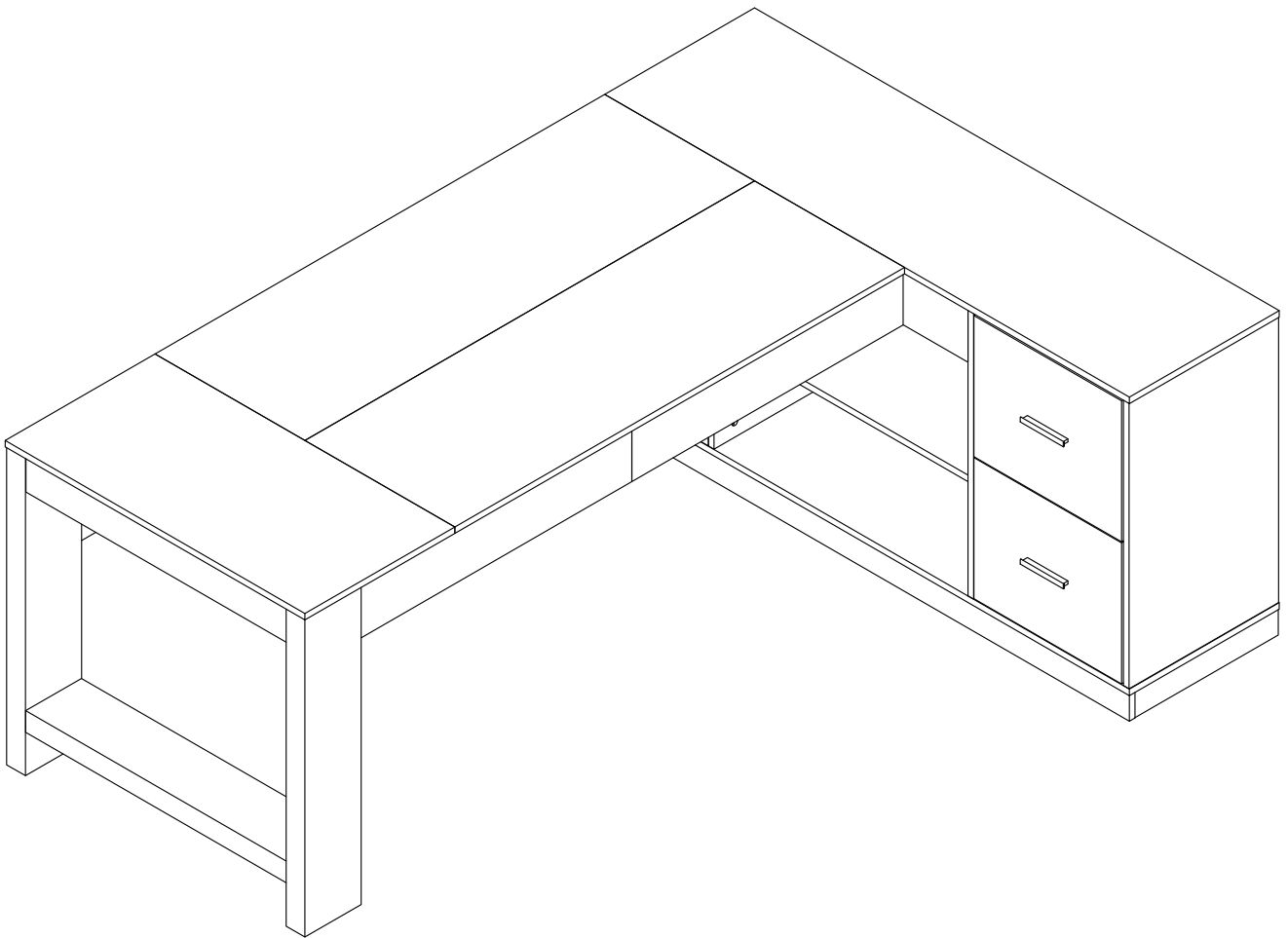

Office Table

Model No.
HOGA-F2445-AB

Contact Us

We're here to help you.

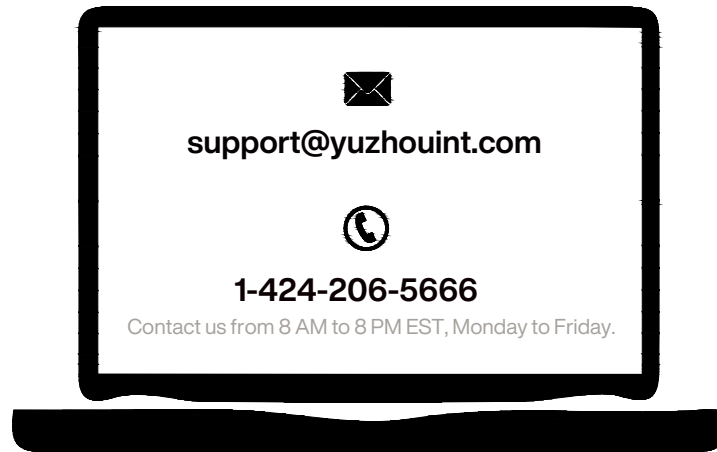

Your satisfaction is our top priority. If you encounter any issues with this product, such as missing or damaged parts, we're here to help. Please retain the original packaging and take photos of the packaging and the product, then contact us as soon as possible.

Warm Tips

1. Carefully read these instructions and keep them for future reference.
2. Check the parts list and confirm everything's there before starting assembly.
3. When assembling, put all parts on a soft, smooth surface like a carpet to avoid scratches.
4. Don't fully tighten screws until all parts are confirmed in place to avoid misalignment.

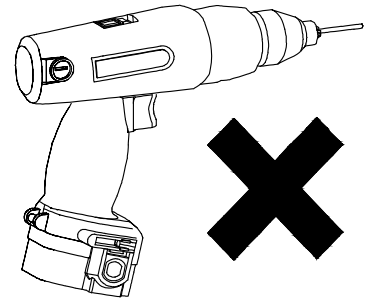
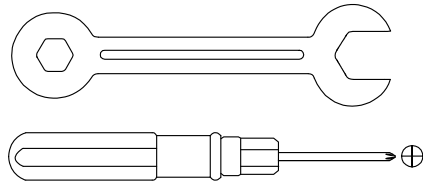
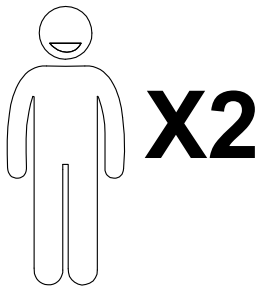

We recommend using hand tools for assembly.

If an electric screwdriver is used, reduce power and torque to avoid damage to the product.

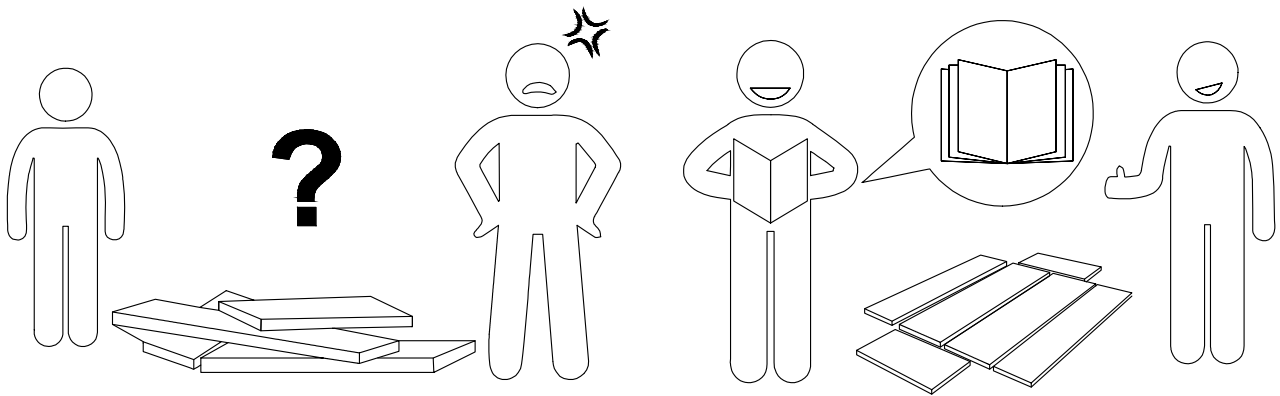

AVOID SCRATCHES

In order to avoid scratching, this furniture should be assembled on a soft surface, such as a rug.

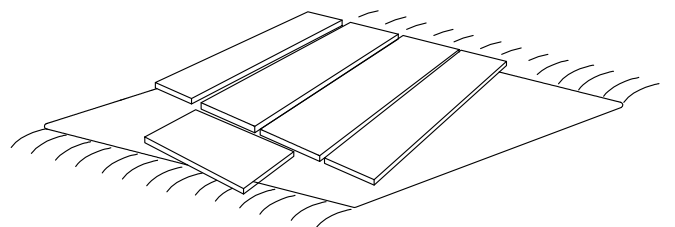
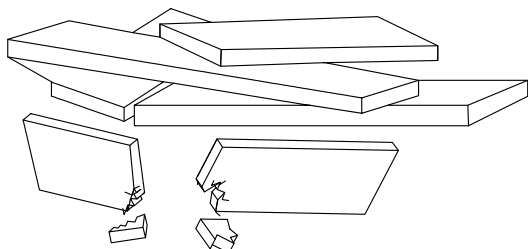

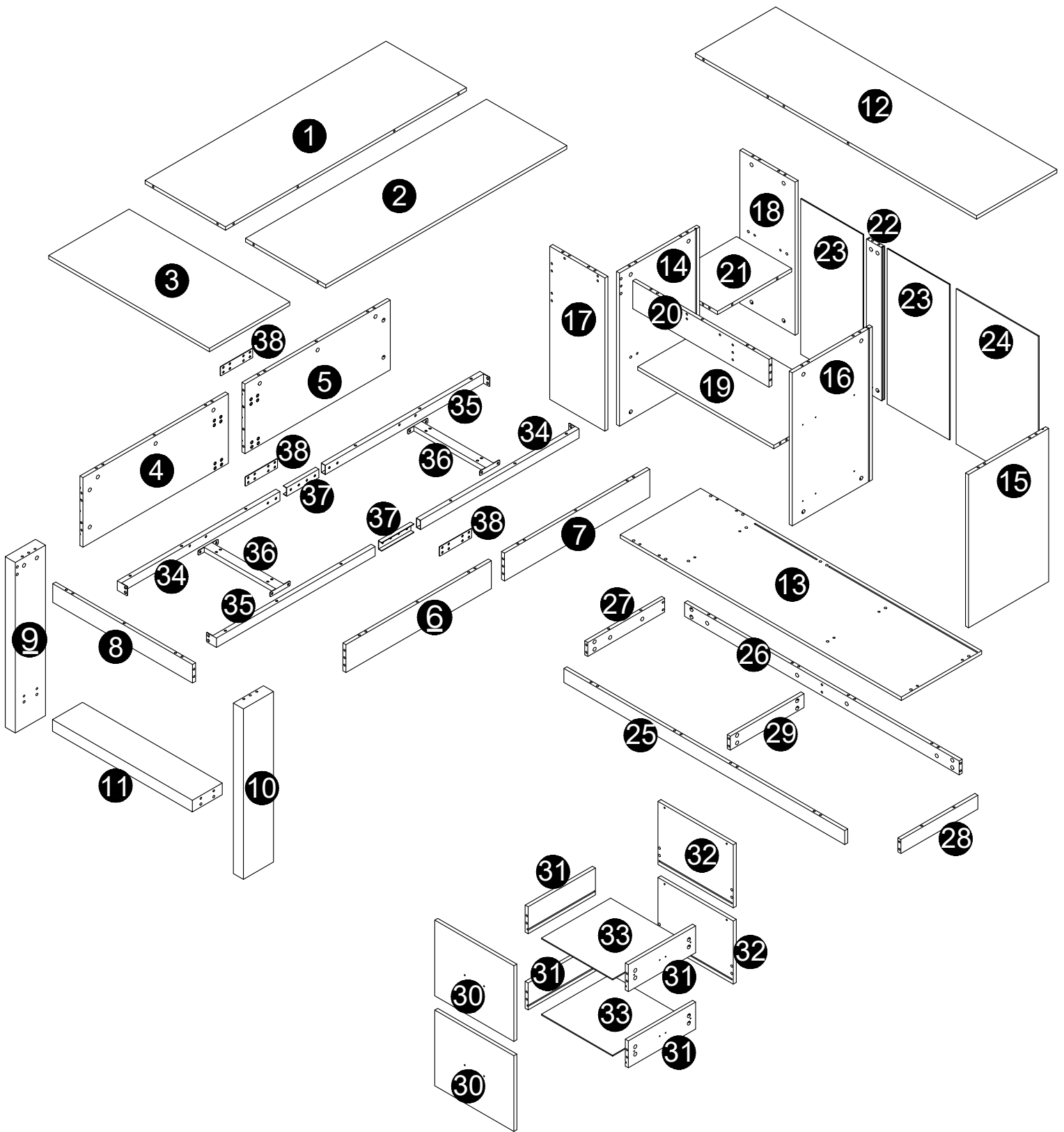

⚠ Caution

Make sure all parts are included. Most board parts are labeled or stamped on the raw edge. Contact us for a free replacement if you encounter any damaged or missing parts.

Parts List

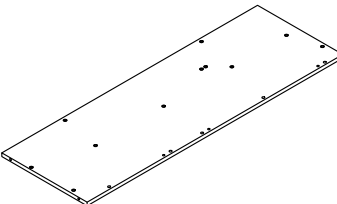
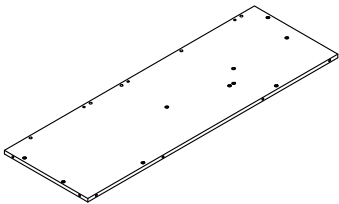
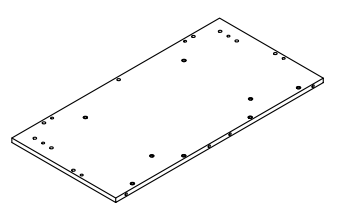
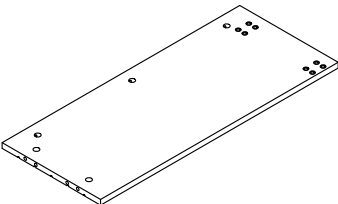
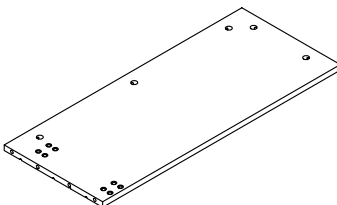
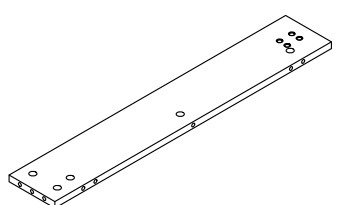
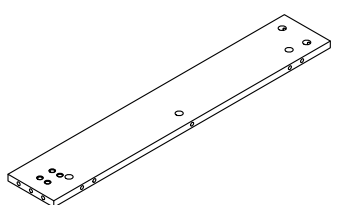
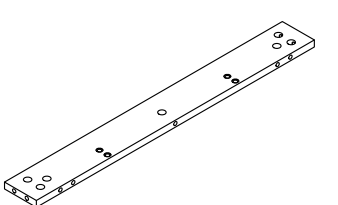
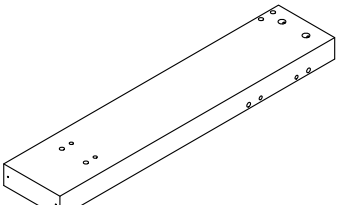
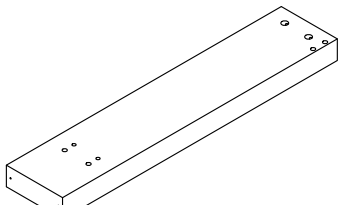
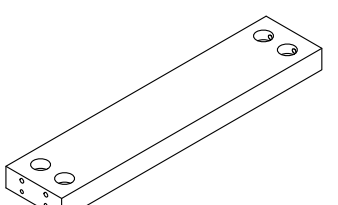
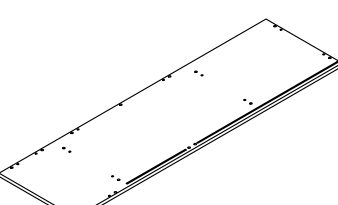
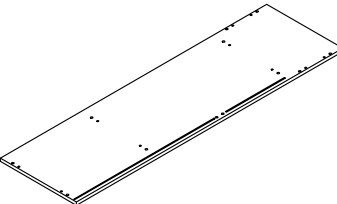
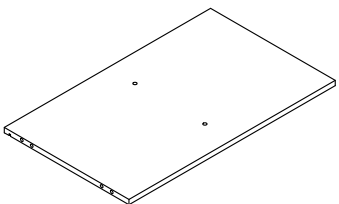
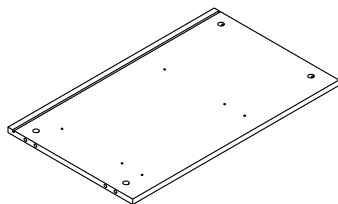
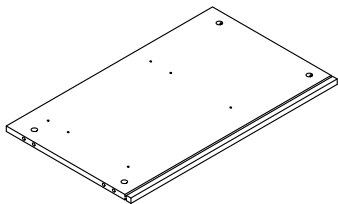
<p>1</p>  <p>1pc</p>	<p>2</p>  <p>1pc</p>	<p>3</p>  <p>1pc</p>	<p>4</p>  <p>1pc</p>
<p>5</p>  <p>1pc</p>	<p>6</p>  <p>1pc</p>	<p>7</p>  <p>1pc</p>	<p>8</p>  <p>1pc</p>
<p>9</p>  <p>1pc</p>	<p>10</p>  <p>1pc</p>	<p>11</p>  <p>1pc</p>	<p>12</p>  <p>1pc</p>
<p>13</p>  <p>1pc</p>	<p>14</p>  <p>1pc</p>	<p>15</p>  <p>1pc</p>	<p>16</p>  <p>1pc</p>

Parts List

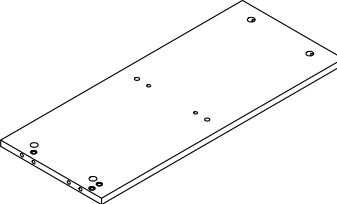
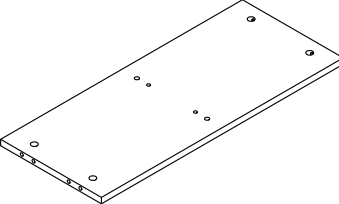
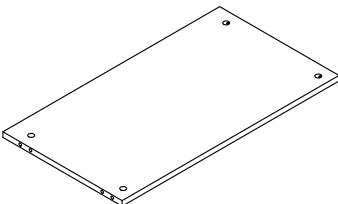
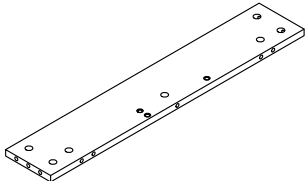
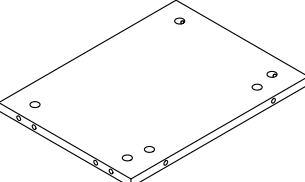
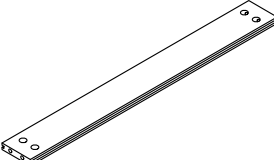
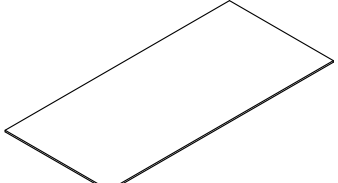
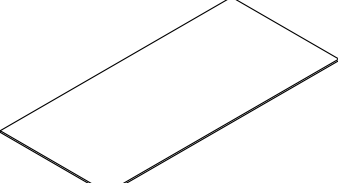
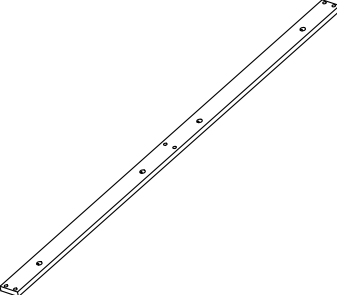
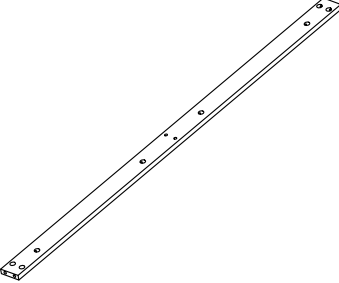
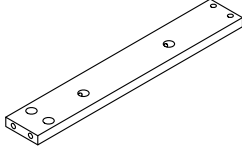
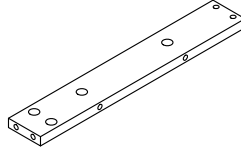
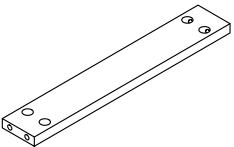
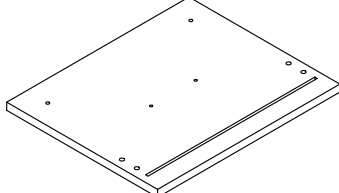
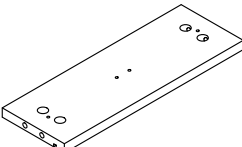
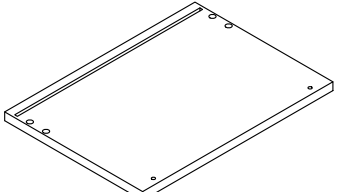
<p>17</p>  <p>1pc</p>	<p>18</p>  <p>1pc</p>	<p>19</p>  <p>1pc</p>	<p>20</p>  <p>1pc</p>
<p>21</p>  <p>1pc</p>	<p>22</p>  <p>1pc</p>	<p>23</p>  <p>2 pcs</p>	<p>24</p>  <p>1pc</p>
<p>25</p>  <p>1pc</p>	<p>26</p>  <p>1pc</p>	<p>27</p>  <p>1pc</p>	<p>28</p>  <p>1pc</p>
<p>29</p>  <p>1pc</p>	<p>30</p>  <p>2 pcs</p>	<p>31</p>  <p>4 pcs</p>	<p>32</p>  <p>2 pcs</p>

Parts List

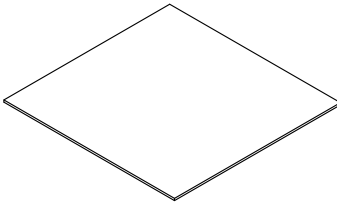
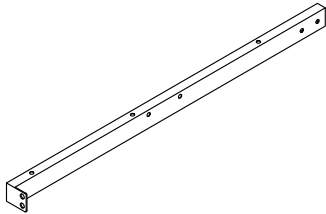
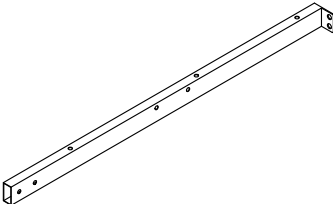
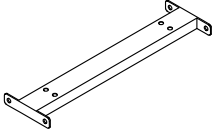
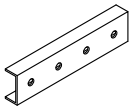
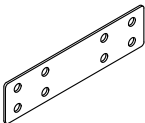
<p>33</p>  <p>2 pcs</p>	<p>34</p>  <p>2 pcs</p>	<p>35</p>  <p>2 pcs</p>	<p>36</p>  <p>2 pcs</p>
<p>37</p>  <p>2 pcs</p>	<p>38</p>  <p>3 pcs</p>		

Before installation, please check if you have received the A and B packages, and check if the parts are complete.

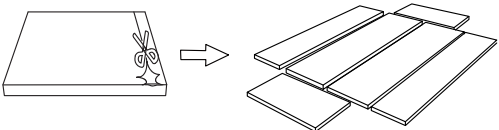

HOGA-F2445-A			
1	1 pc	2	1 pc
3	1 pc	4	1 pc
5	1 pc	6	1 pc
7	1 pc	8	1 pc
21	1 pc	27	1 pc
28	1 pc	29	1 pc
30	2 pcs	31	4 pcs
32	2 pcs	33	2 pcs



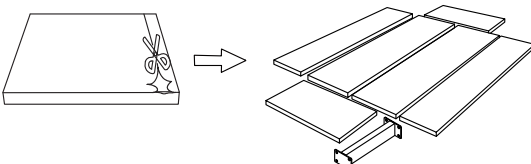



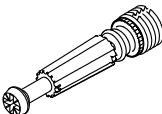
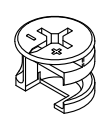
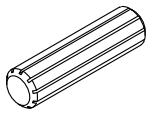
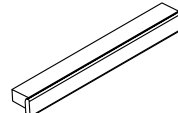

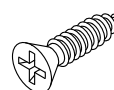
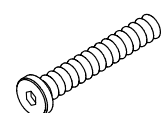
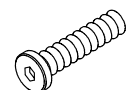

HOGA-F2445-B			
9	1 pc	10	1 pc
11	1 pc	12	1 pc
13	1 pc	14	1 pc
15	1 pc	16	1 pc
17	1 pc	18	1 pc
19	1 pc	20	1 pc
22	1 pc	23	2 pcs
24	1 pc	25	1 pc
26	1 pc	34	2 pcs
35	2 pcs	36	2 pcs
37	2 pcs	38	3 pcs

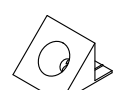

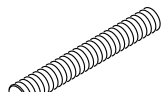

Hardware List

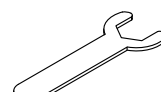
A	B	C	D	E	F
					
Ø6x40mm	Ø15x12mm	Ø8x30mm	114x17x11mm	M4x18	Ø3.5x14mm
112 pcs	112 pcs	81 pcs	2 pcs	4 pcs	24 pcs

G	H	I	J	K	L
					
Ø3x18mm	M6x50mm	M6x30mm	M6x12mm		Ø21
14 pcs	12 pcs	8 pcs	60 pcs	14 pcs	12 pcs

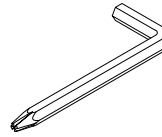
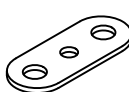
M	N	O	P	Q	R
					
Ø21	M8x70mm		M8		
10 pcs	4 pcs	4 pcs	4 pcs	1 pc	10 pcs

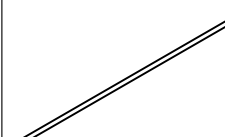
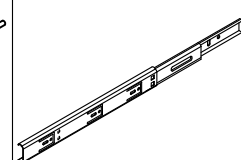
S	T	U	V	W	
					
M4	50x20x2mm		Ø5x355mm	340mm	
1 pc	4 pcs	2 pcs	4 pcs	2 sets	

Installation of Cams and Pins

Step 1-2: Align the plastic part with the mounting hole and press it in. If you can't press it in, loosen the screw counter clockwise or completely remove the screw from the plastic part and try again.

Step 3-4: After pressing the plastic part into place, use a screwdriver to tighten the screw clockwise.

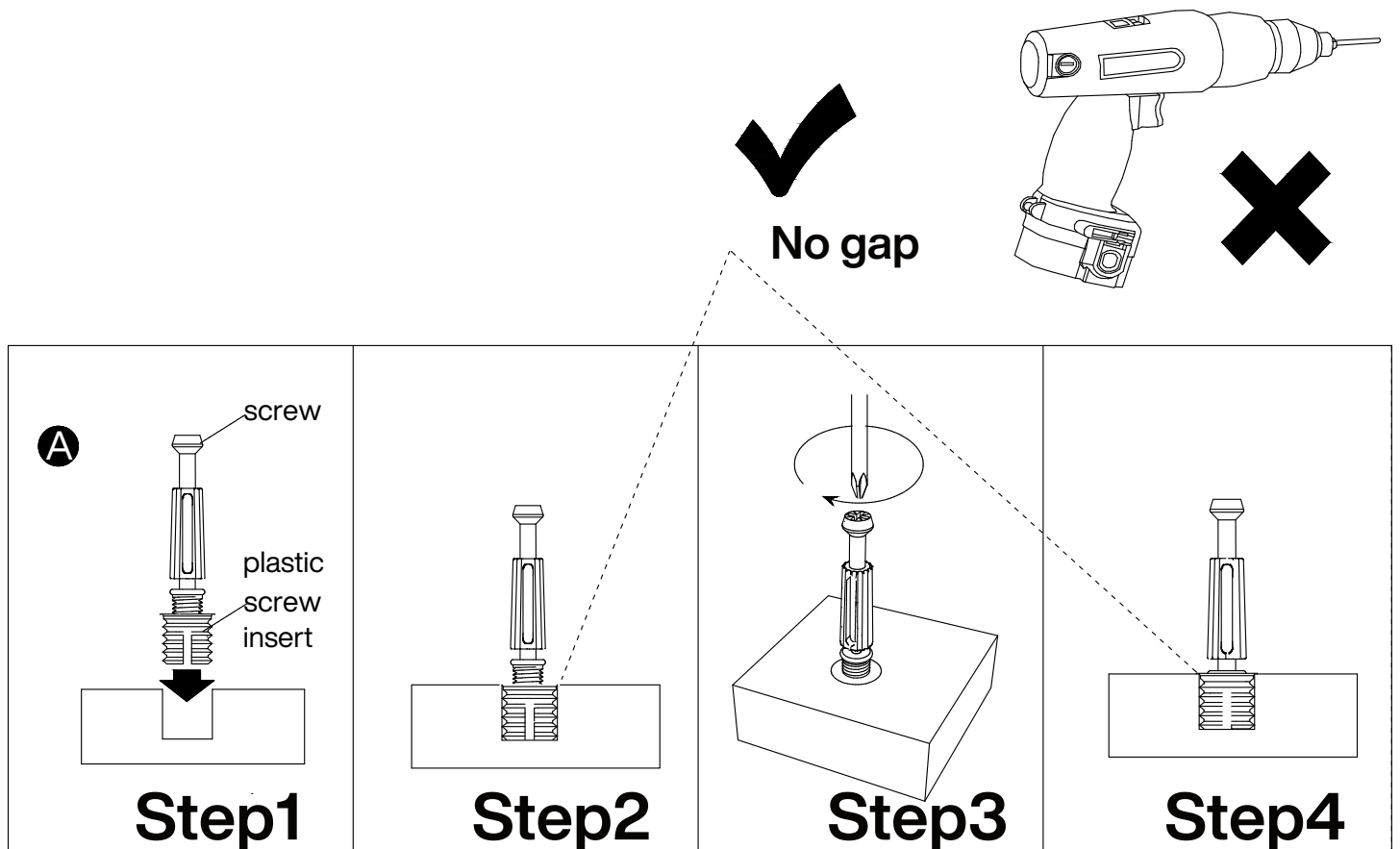

Screw the pin into the hole. Set the cams correctly by aligning the head of the cams with the lock pins. Lock the cam by turning the cam head with a screwdriver until it is tightened. Please do not use an electric screwdriver to assemble the unit.

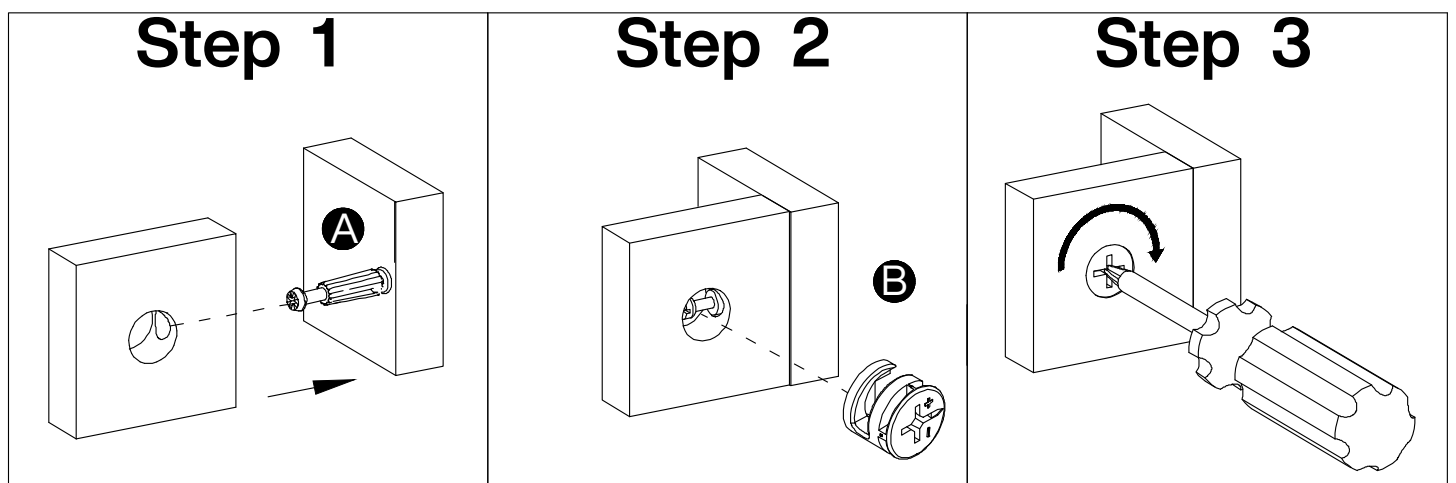

Please split component "W" into "W-1" and "W-2" before assembling the slide and then proceed to the next step of assembly

Step 1

Pull apart component "W" to each side, and then gently push up the lever of component "W-2"

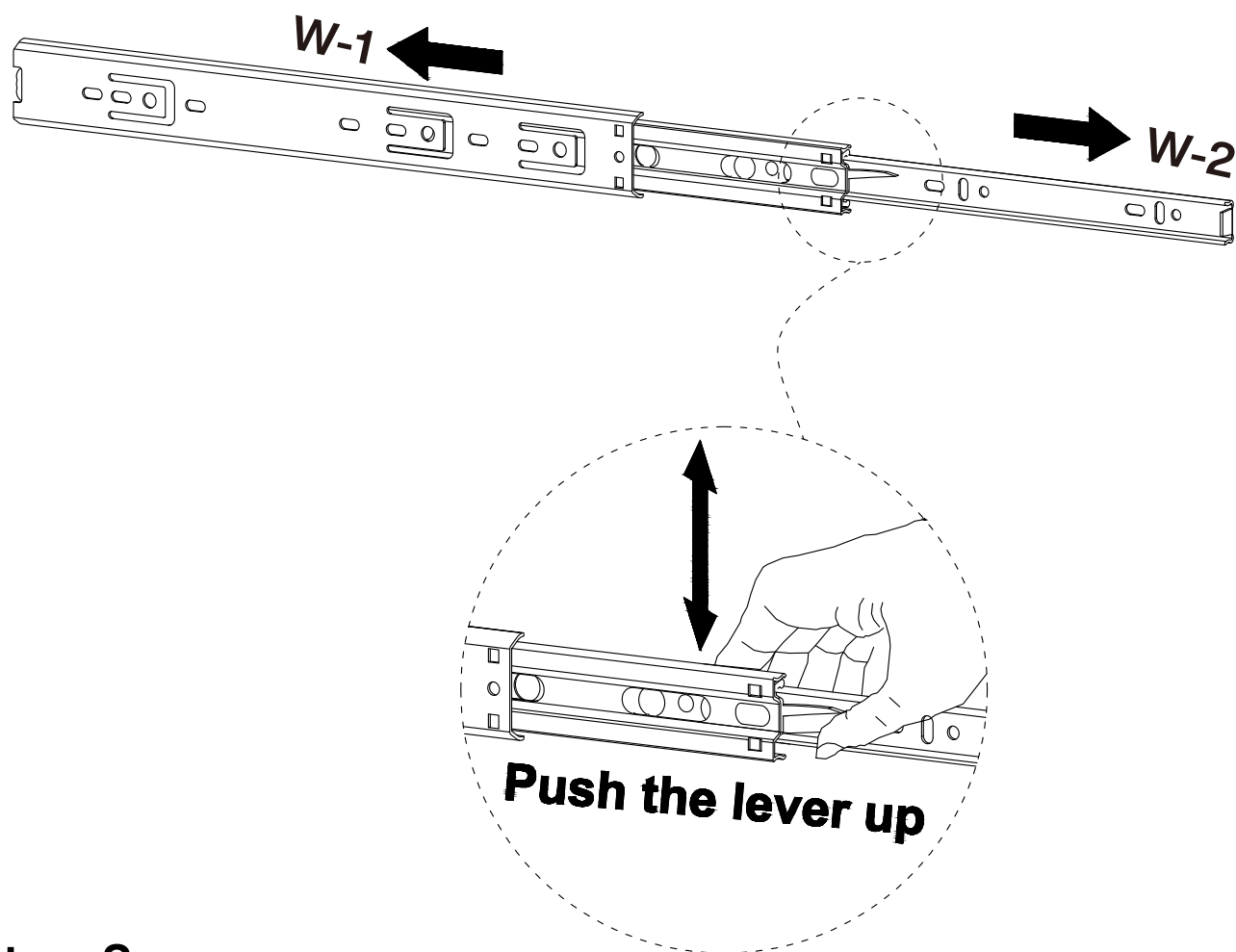

Step 2 Split component "W-1" and "W-2"

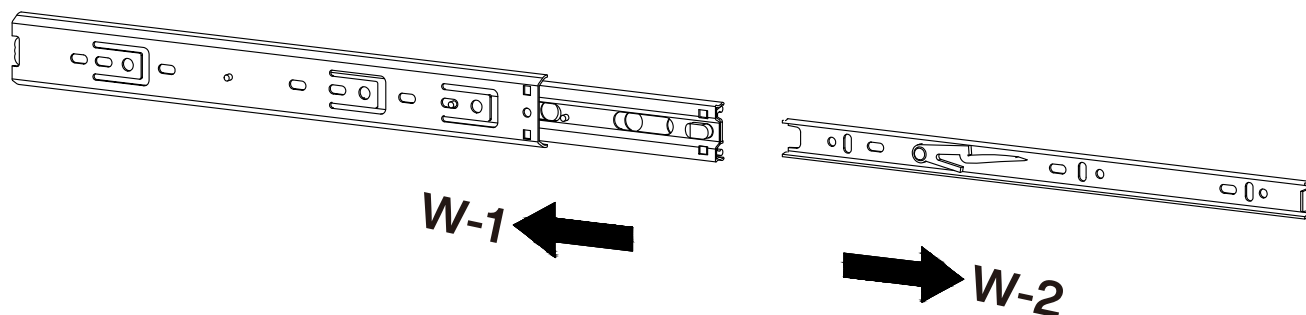

1

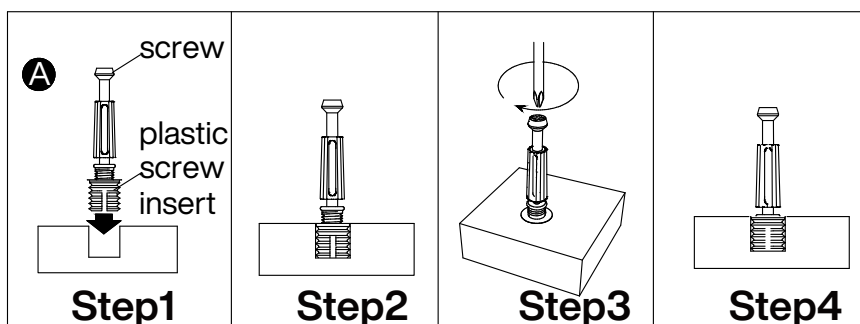
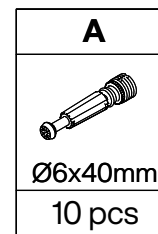
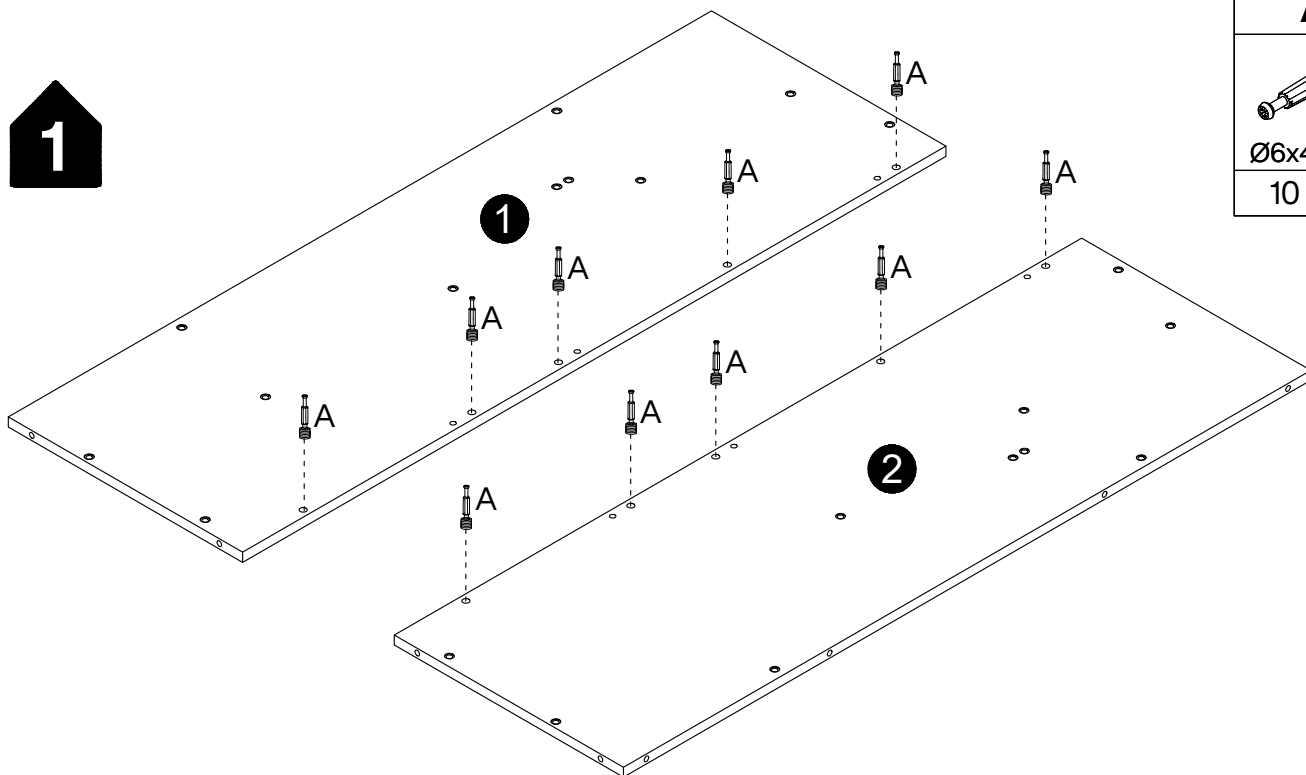

2

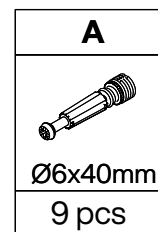
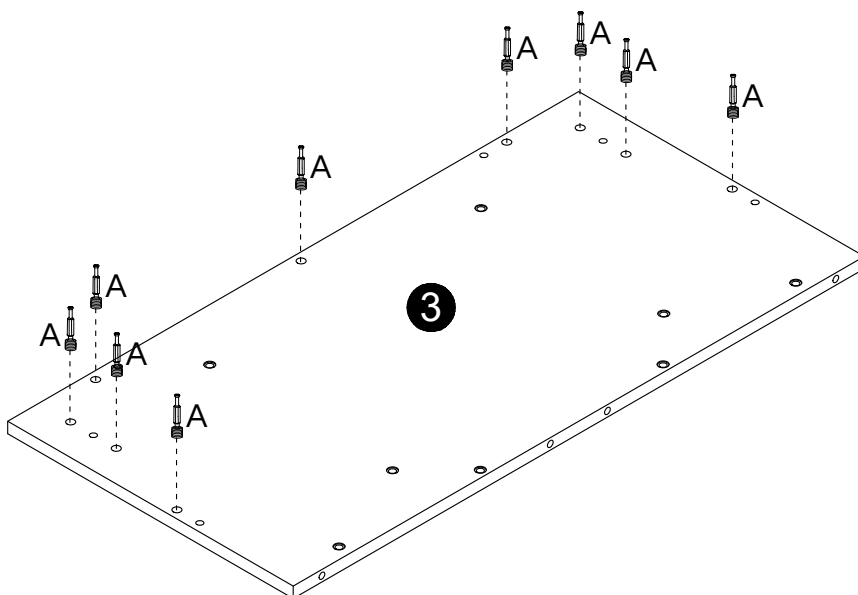

3

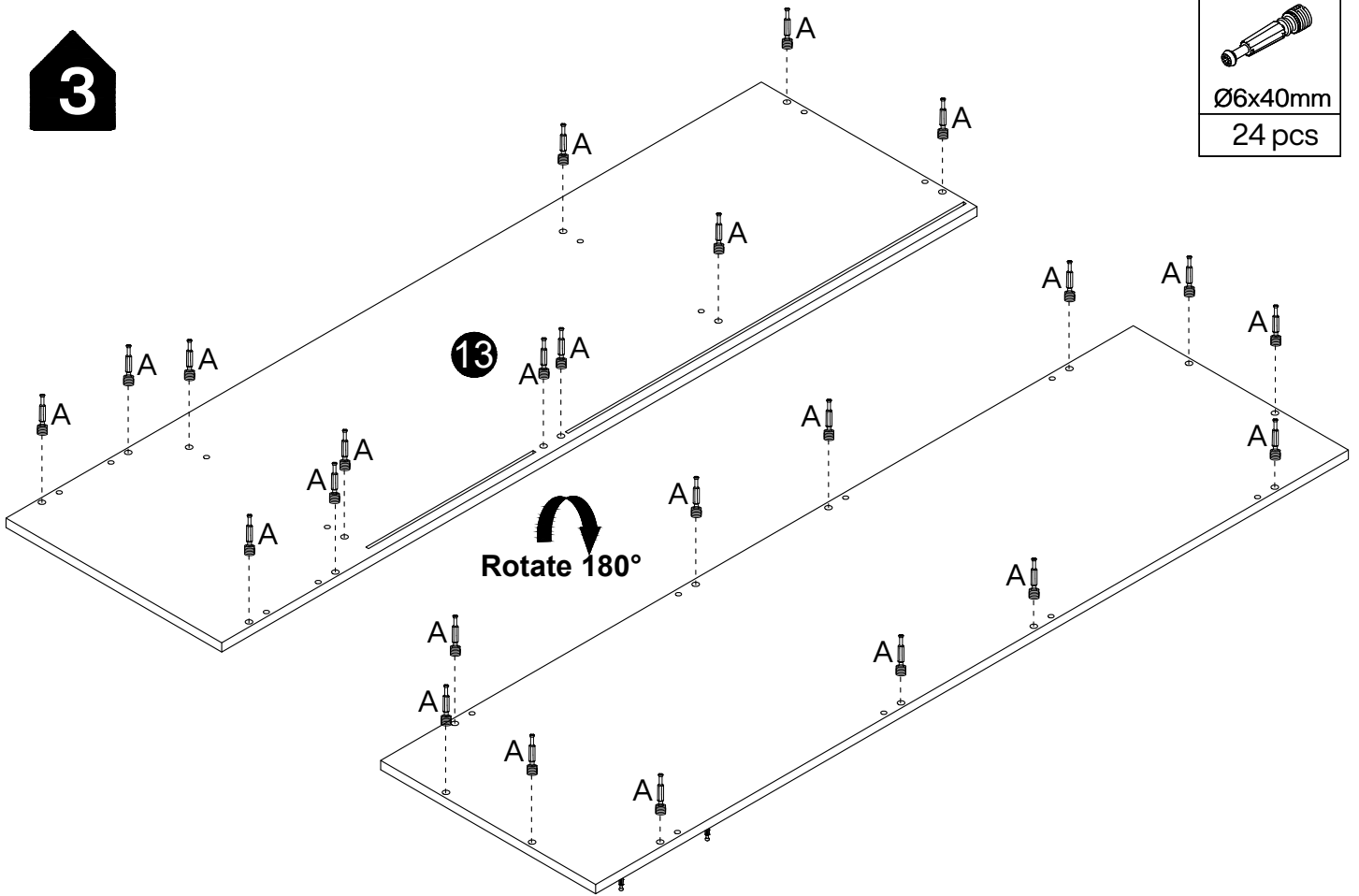

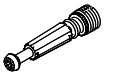
A

Ø6x40mm
24 pcs

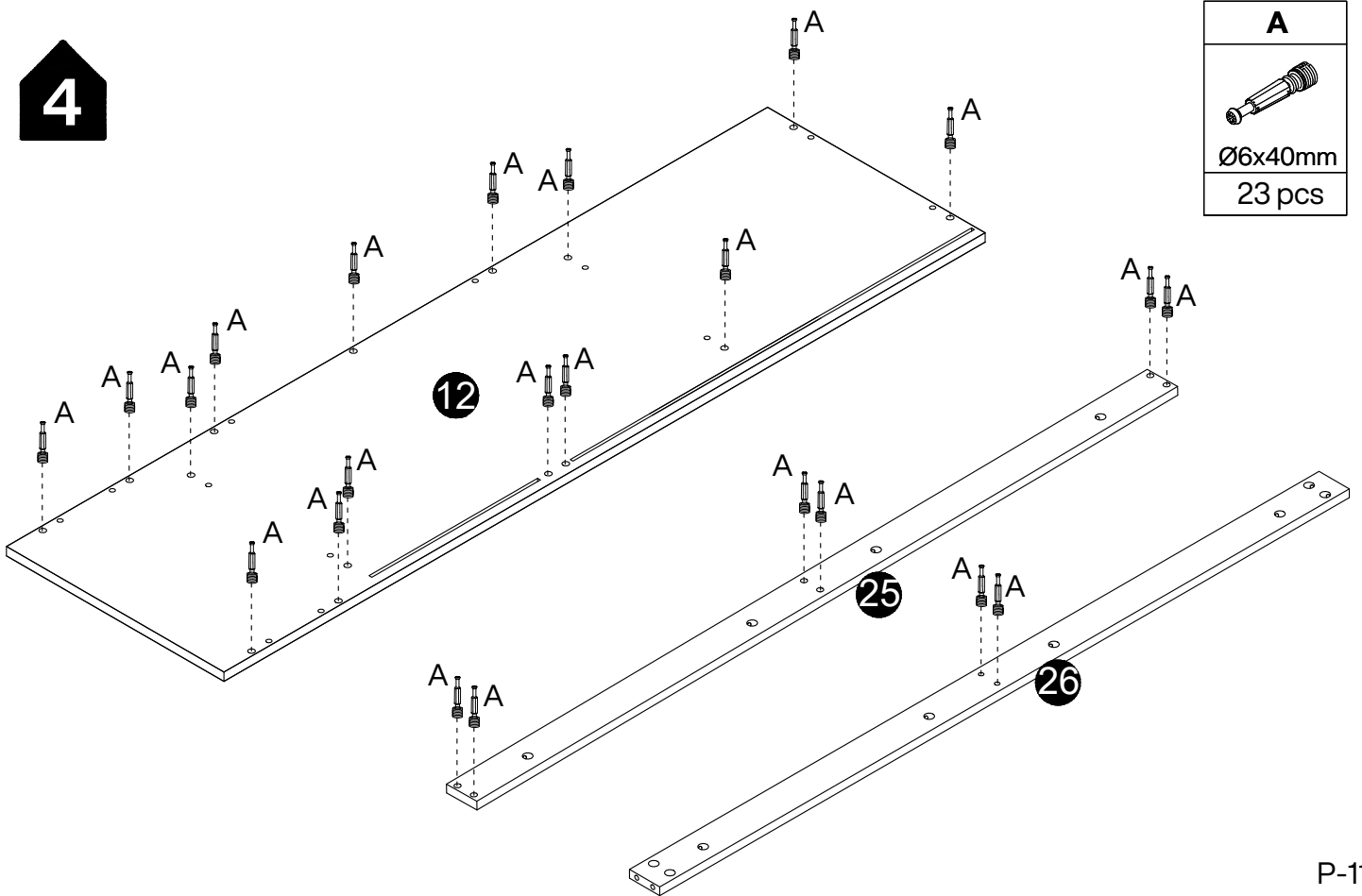

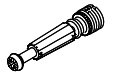
4

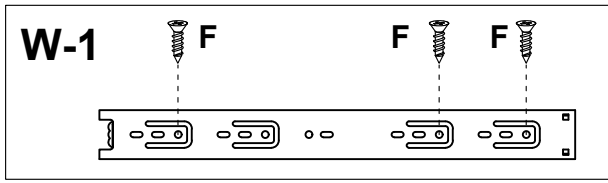

A

Ø6x40mm
23 pcs

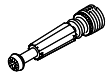
7

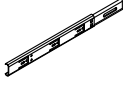

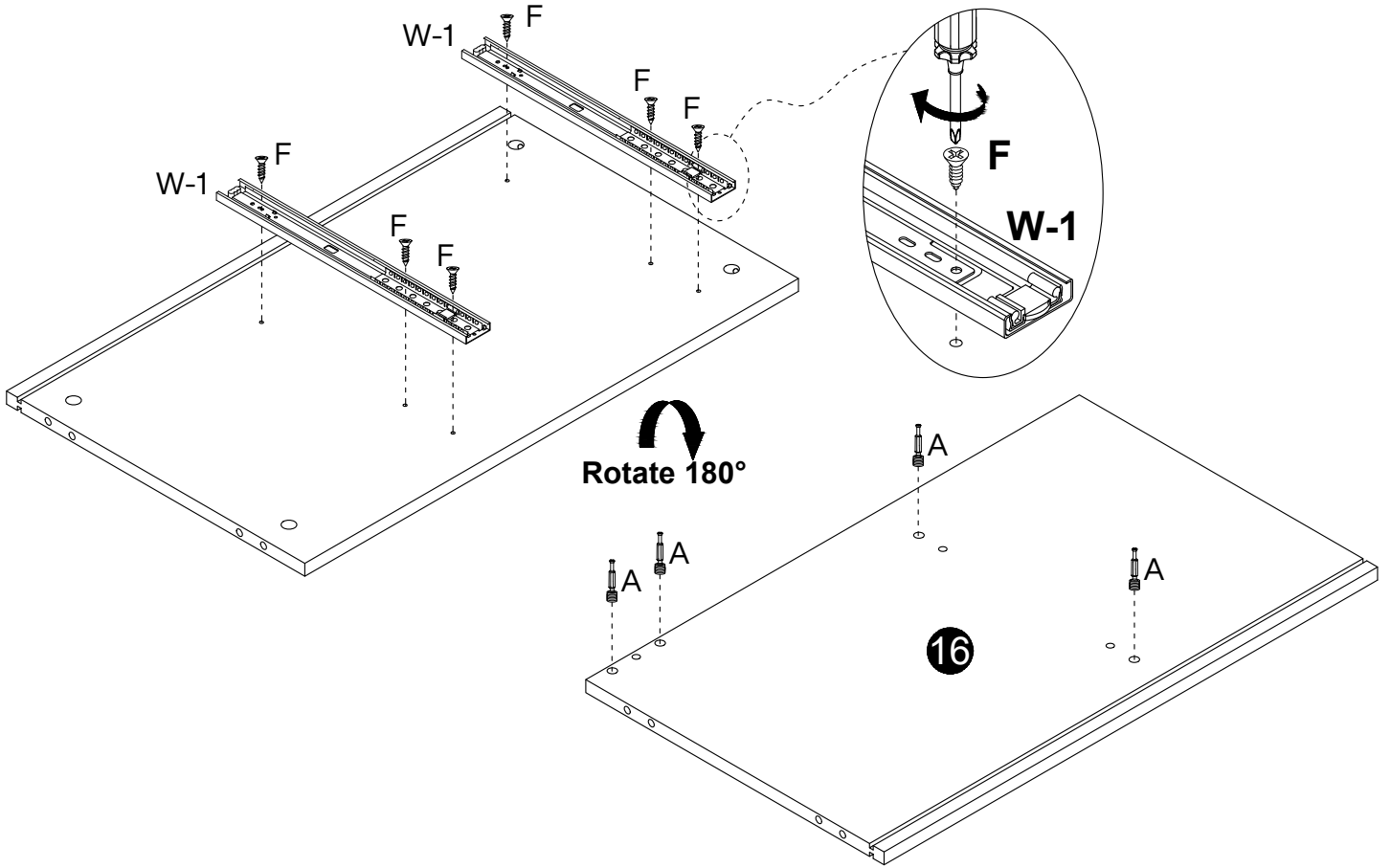
A	F	W-1
		
Ø6x40mm	3.5x14mm	340mm
4 pcs	6 pcs	2 pcs



8

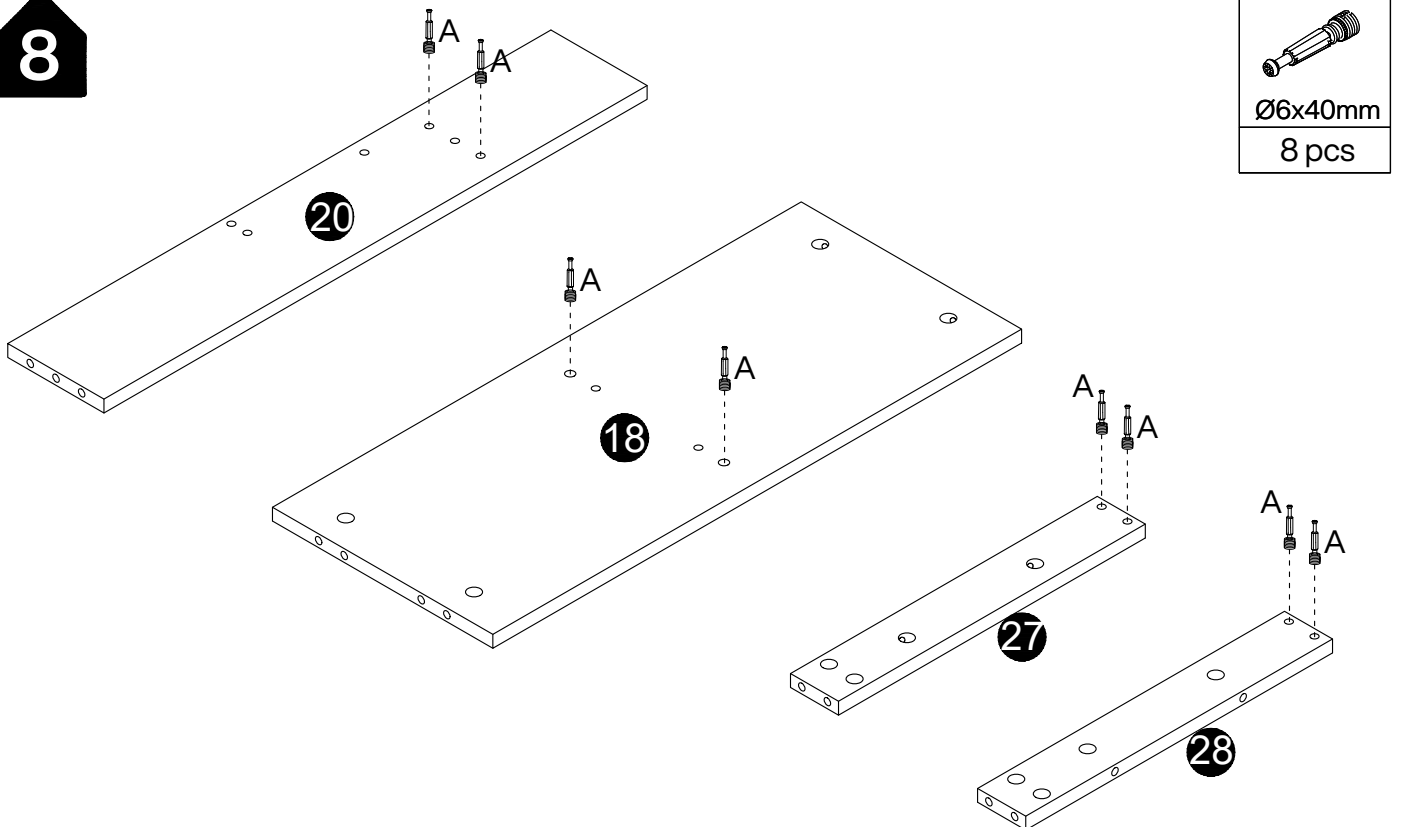

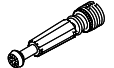
A

Ø6x40mm
8 pcs

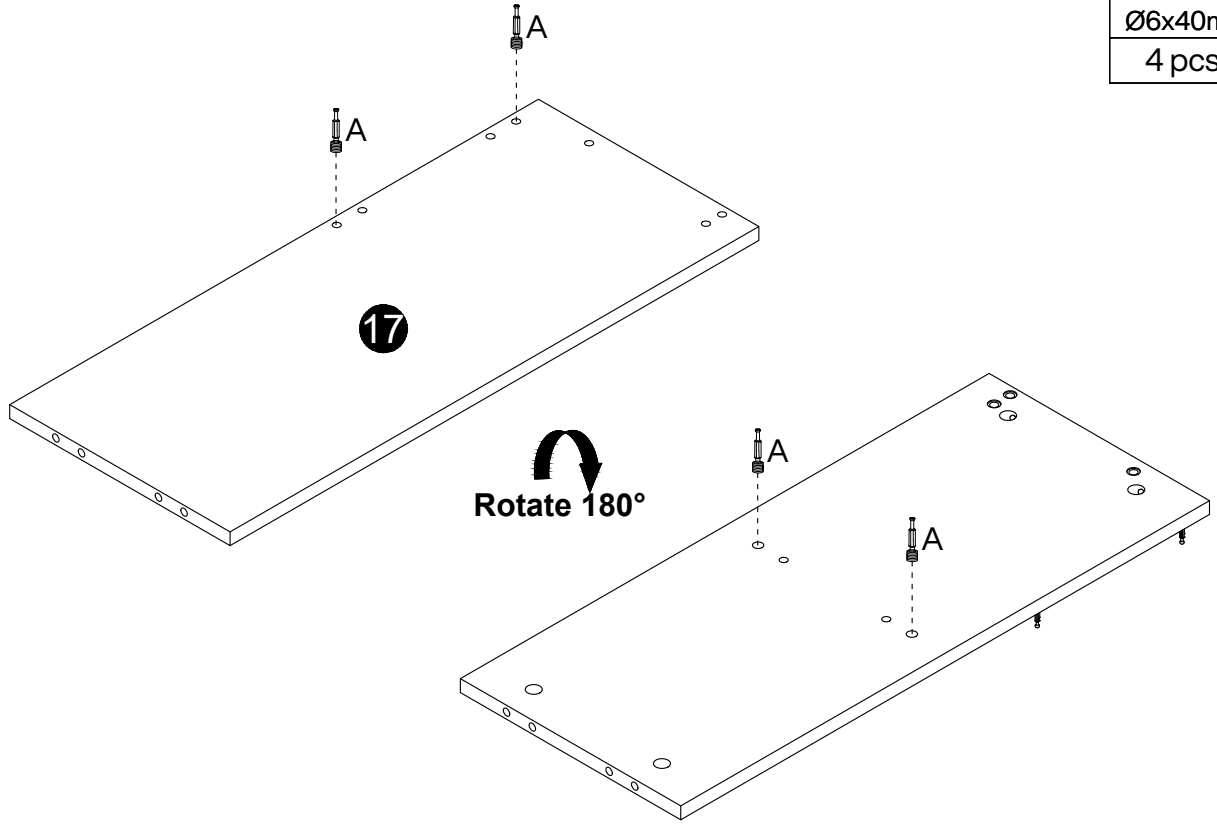
9

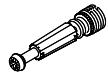

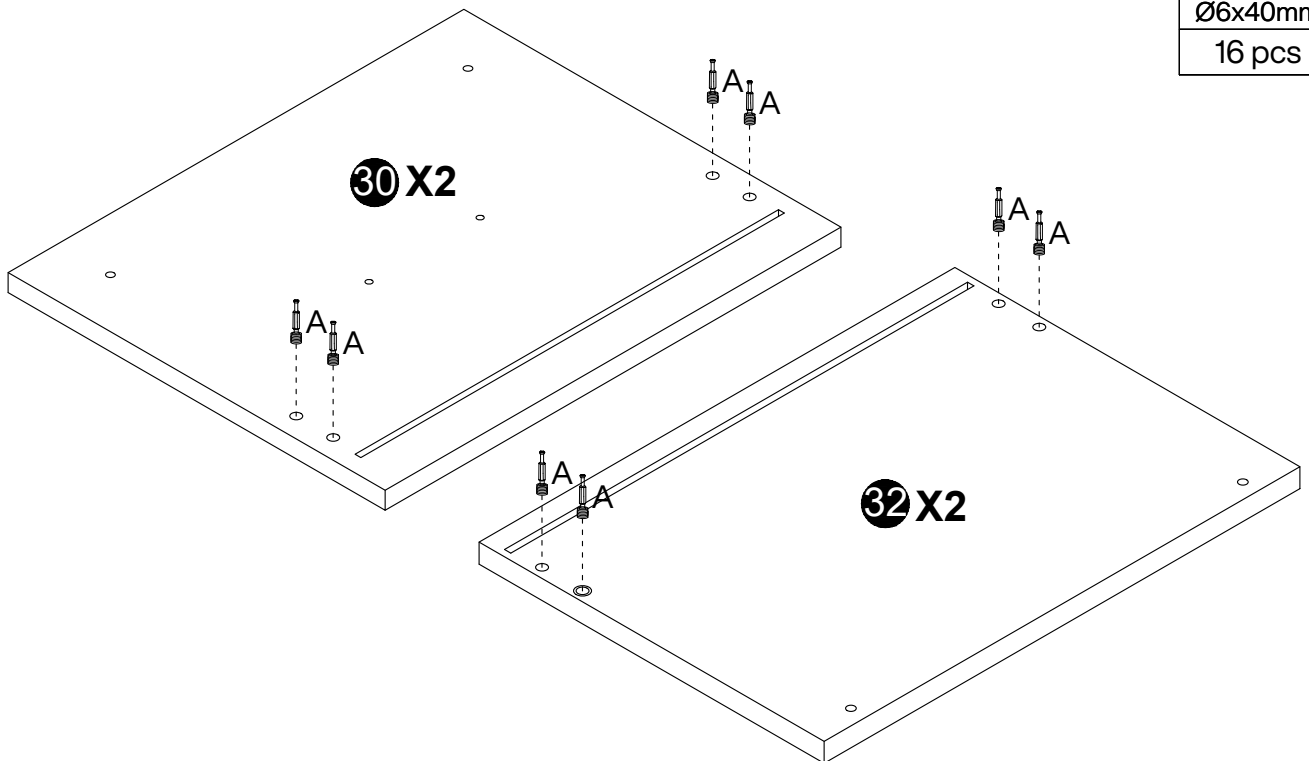

A

Ø6x40mm
4 pcs

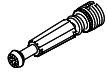
10





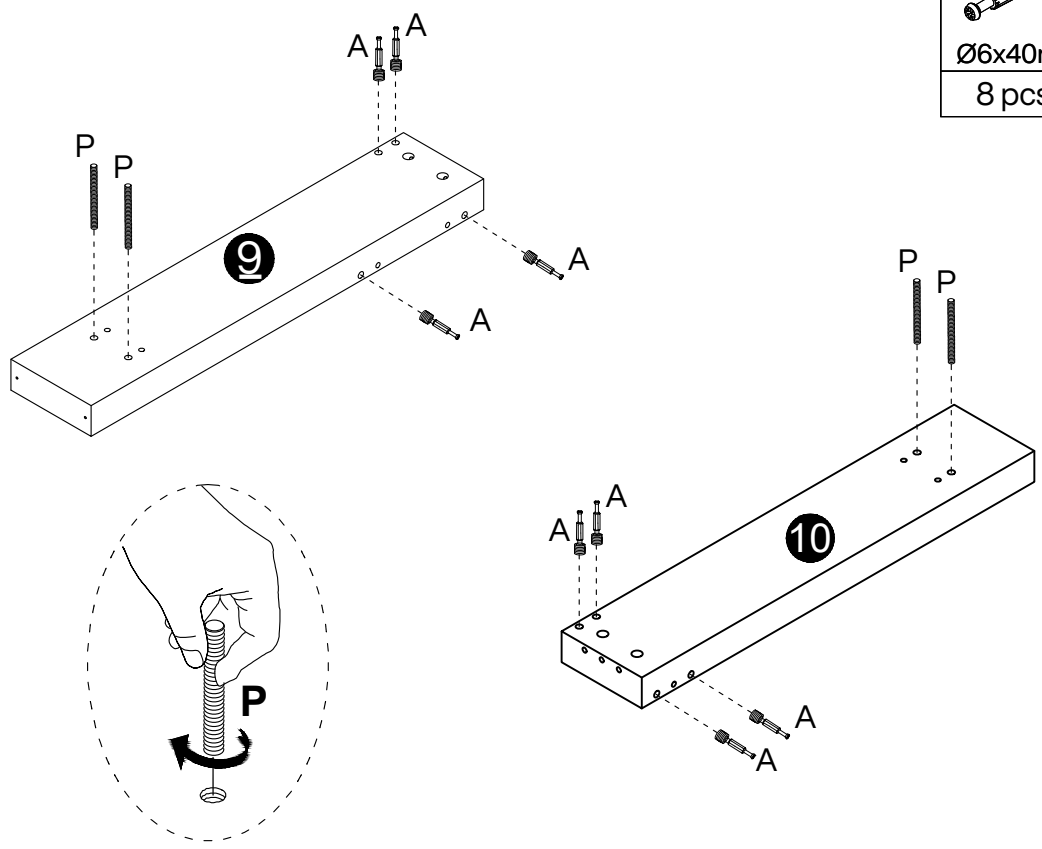

A

Ø6x40mm
16 pcs

11

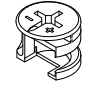
A	N
	
Ø6x40mm	M8x70mm
8 pcs	4 pcs





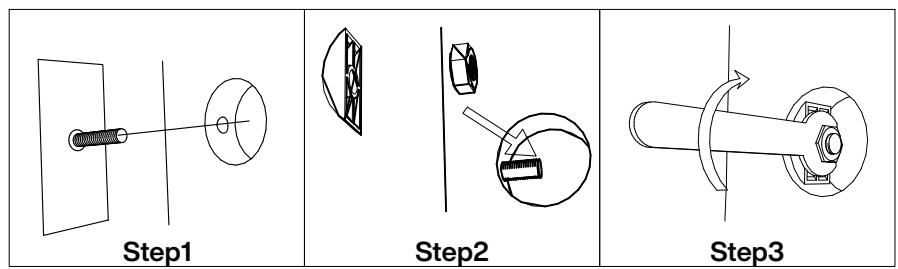
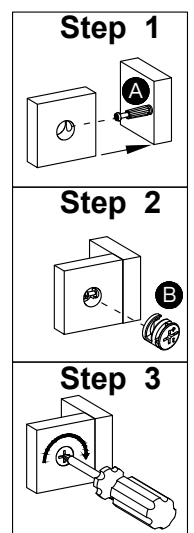
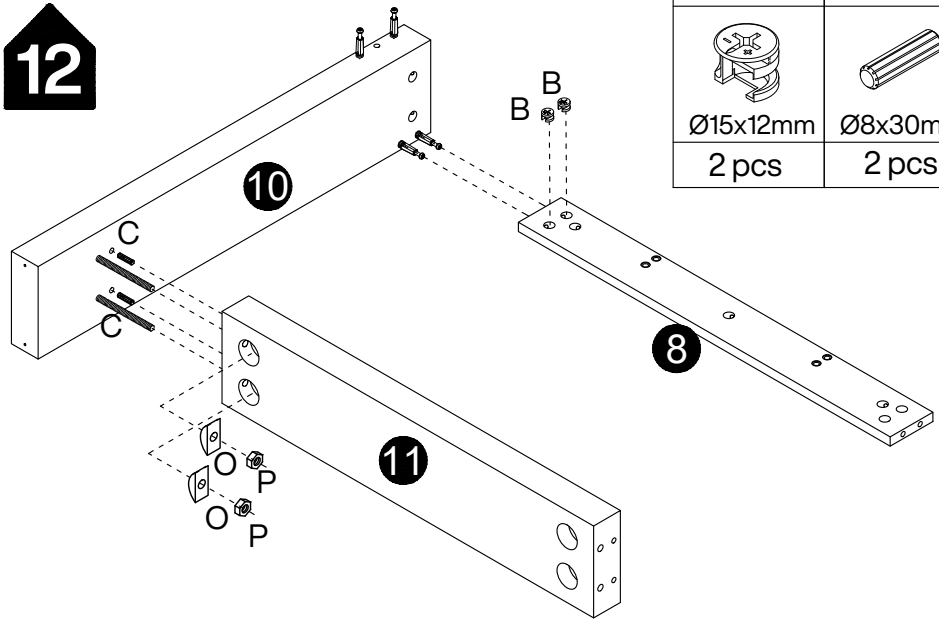

12

B	C	O	P	Q
				
Ø15x12mm	Ø8x30mm		M8	
2 pcs	2 pcs	2 pcs	2 pcs	1 pc



13

B	C	O	P
			
Ø15x12mm	Ø8x30mm		M8
2 pcs	2 pcs	2 pcs	2 pcs

Q

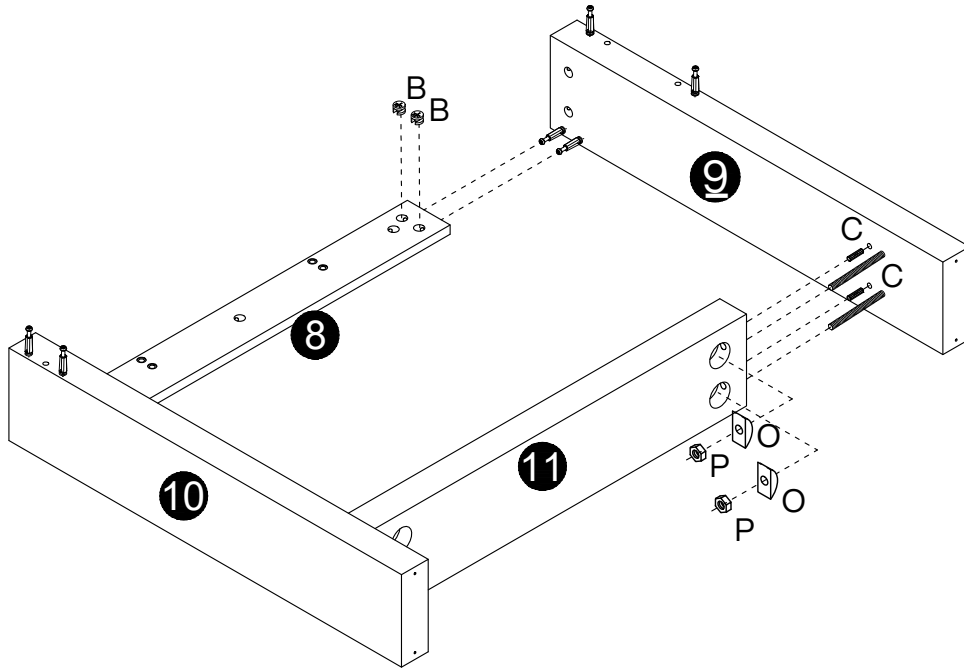
1 pc



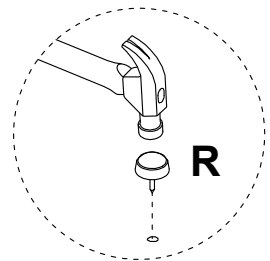
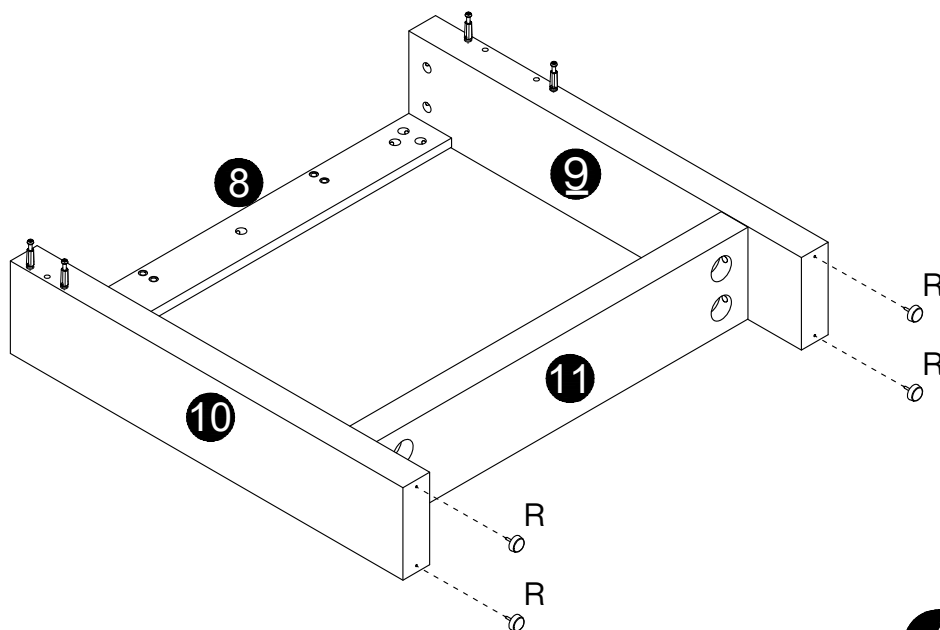

14

R

4 pcs



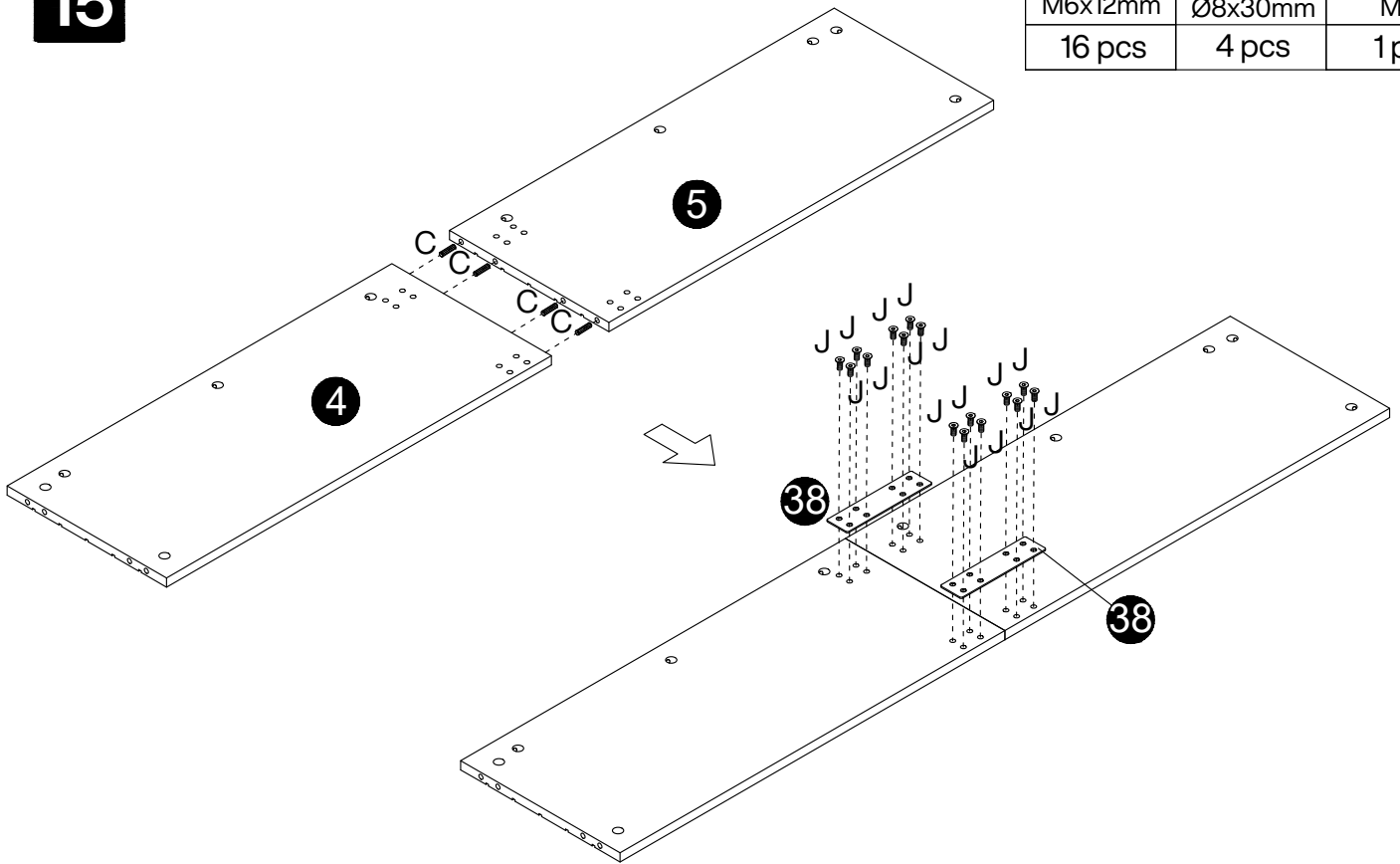

⚠ Caution! Tap lightly

15

J	C	S
		
M6x12mm 16 pcs	Ø8x30mm 4 pcs	M4 1 pc



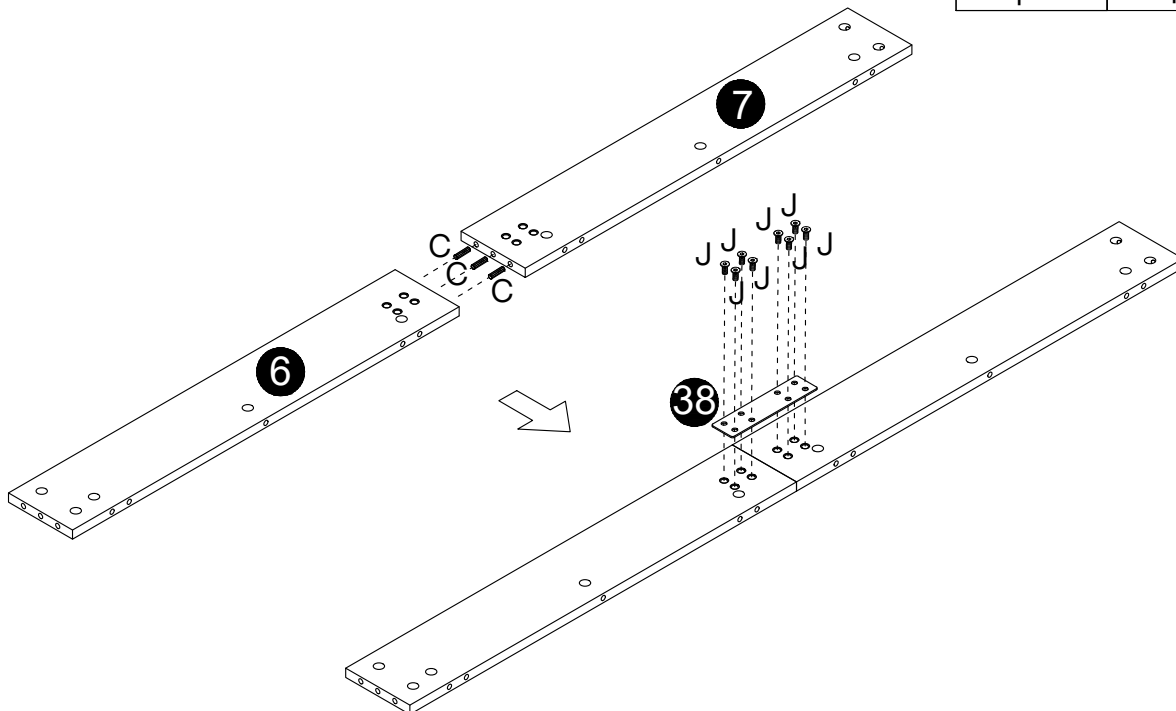

16

J	C	S
		
M6x12mm 8 pcs	Ø8x30mm 3 pcs	M4 1 pc



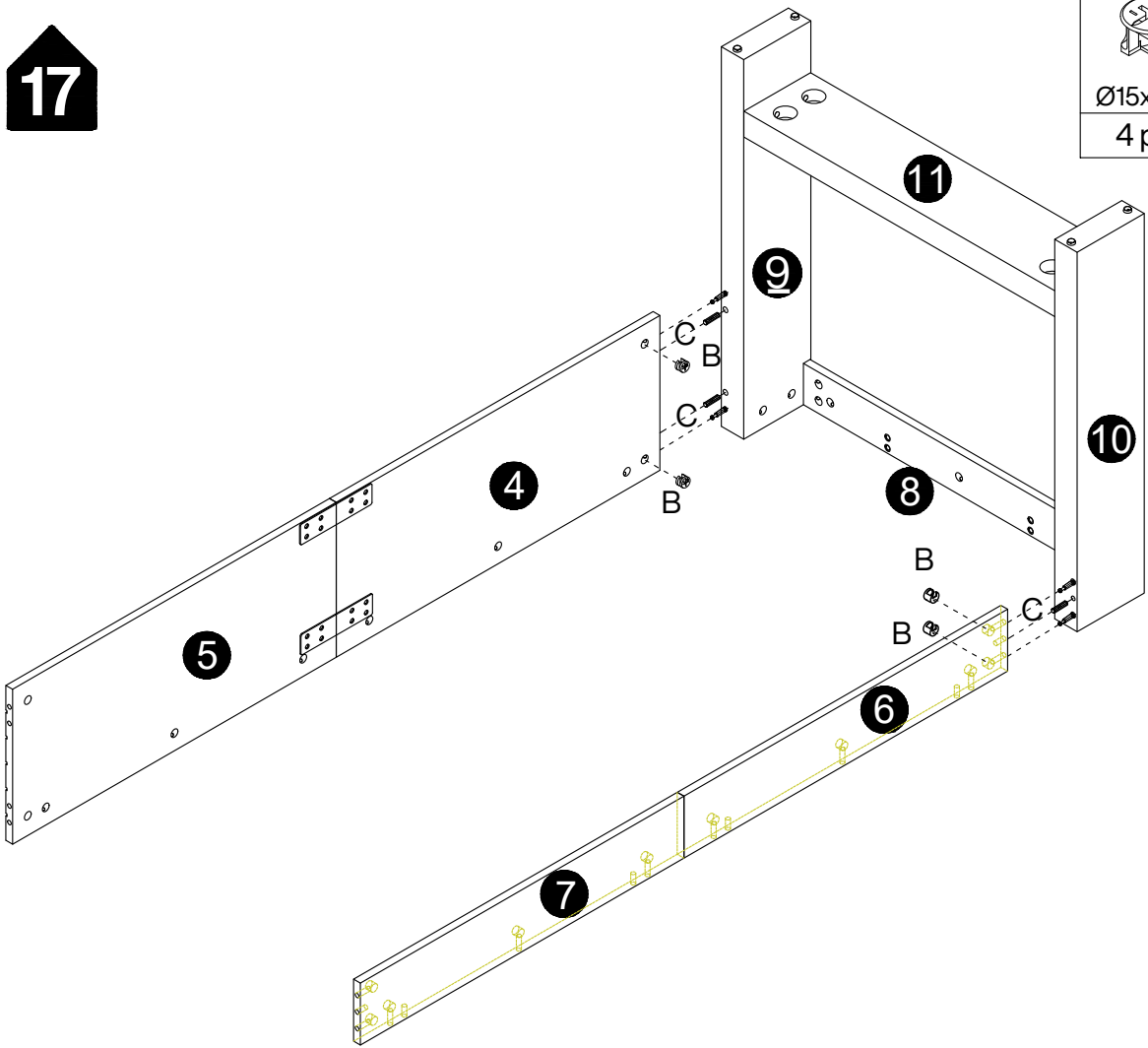

17

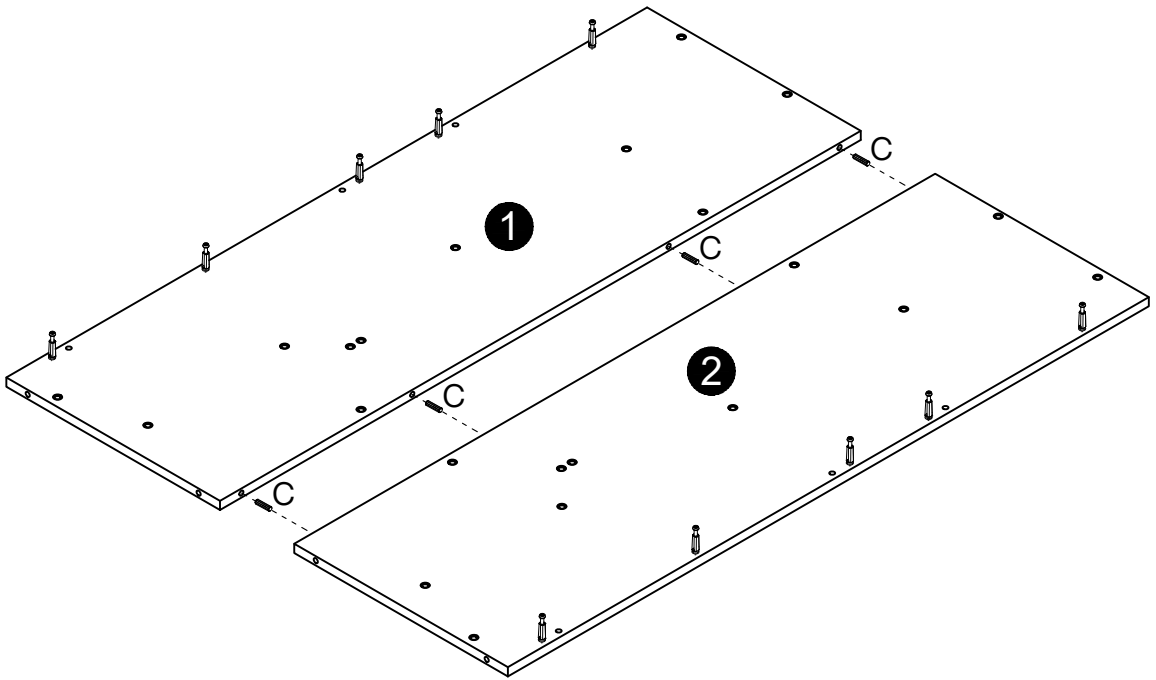

B	C
	
Ø15x12mm	Ø8x30mm
4 pcs	3 pcs

18





C

Ø8x30mm
4 pcs

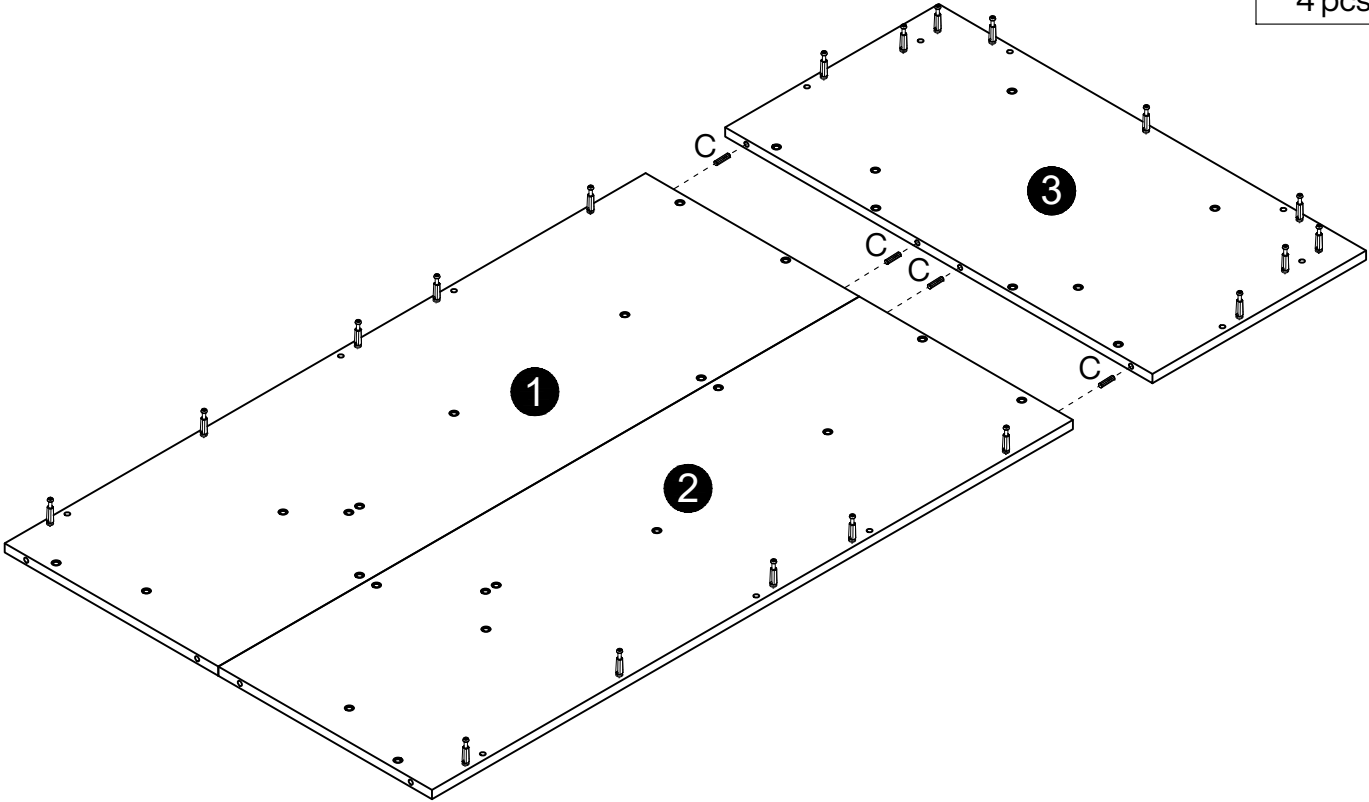
19

C

Ø8x30mm
4 pcs



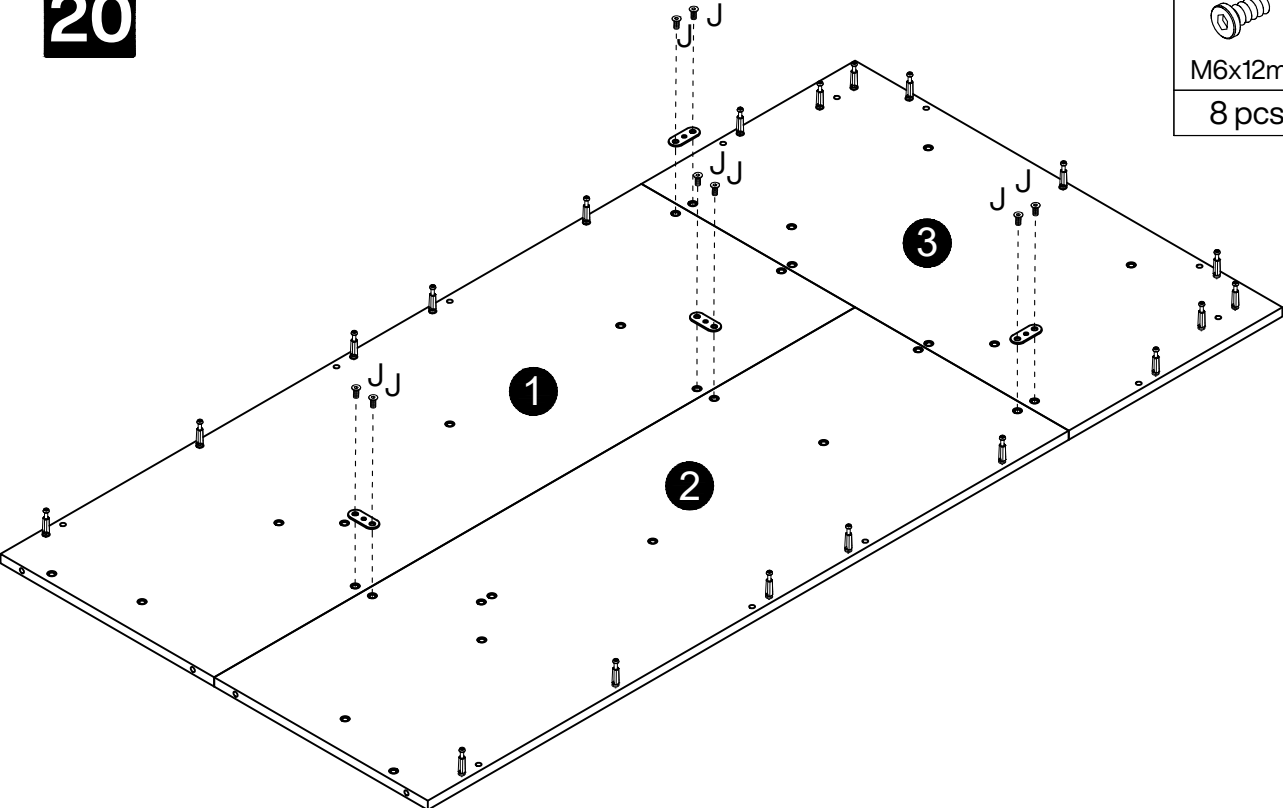

20

J	T
	
M6x12mm	50x20x2mm
8 pcs	4 pcs



21

B	C
	
Ø15x12mm	Ø8x30mm
19 pcs	12 pcs

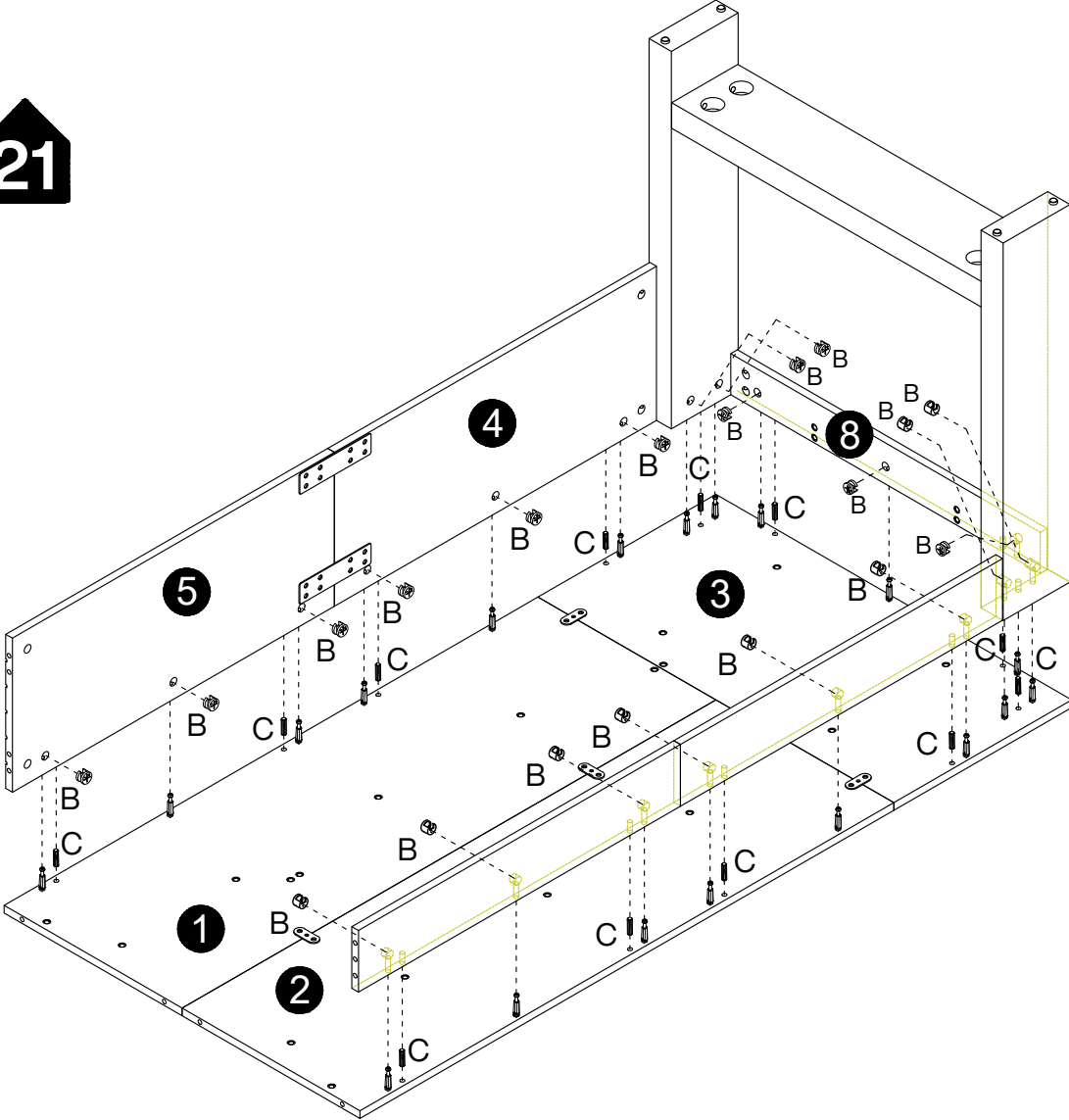

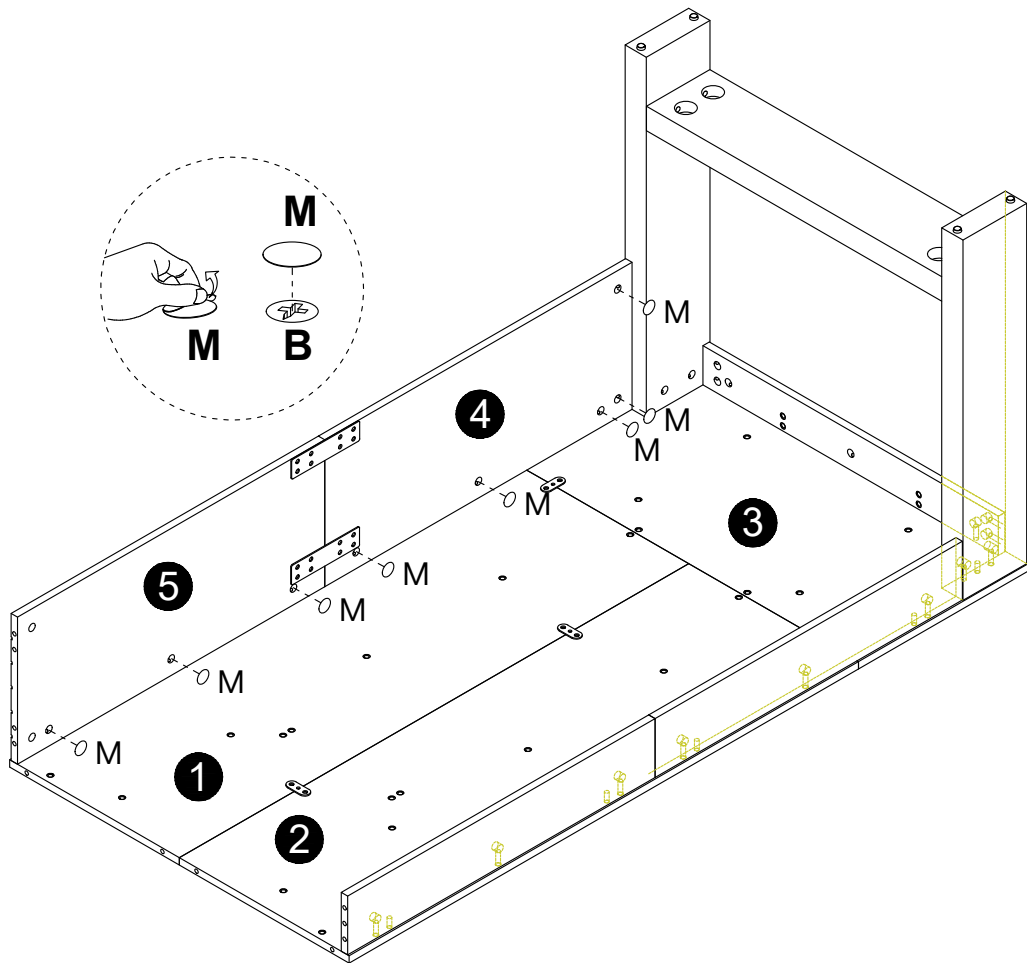
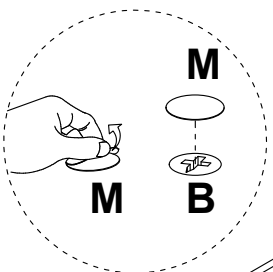

22

M

Ø21mm
8 pcs



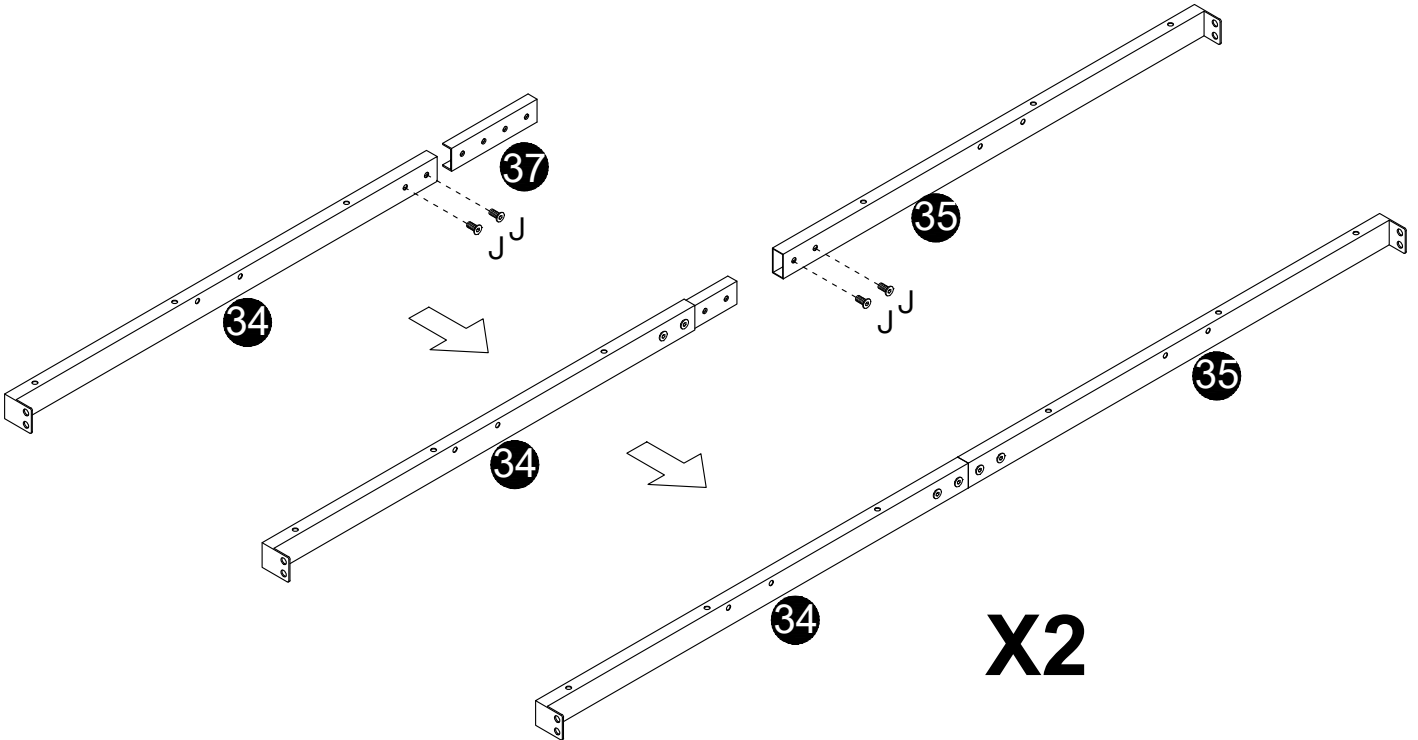

23

J	S
 M6x12mm	 M4
8 pcs	1 pc



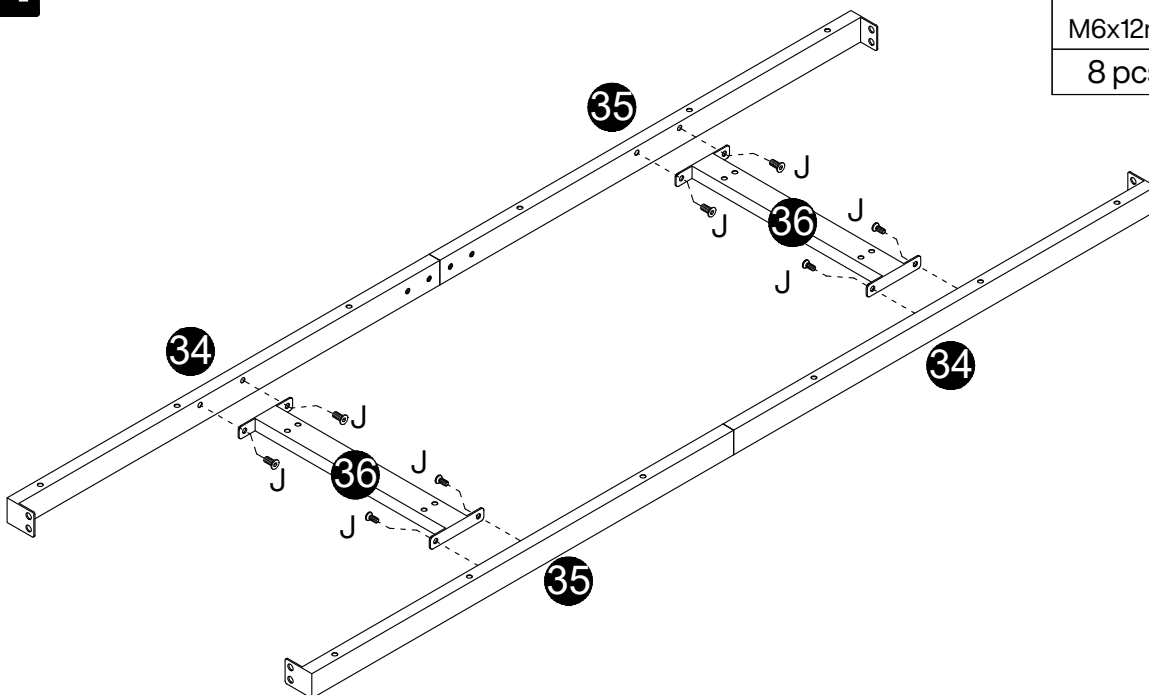

24

J	S
 M6x12mm	 M4
8 pcs	1 pc

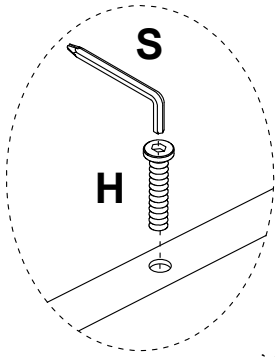

25

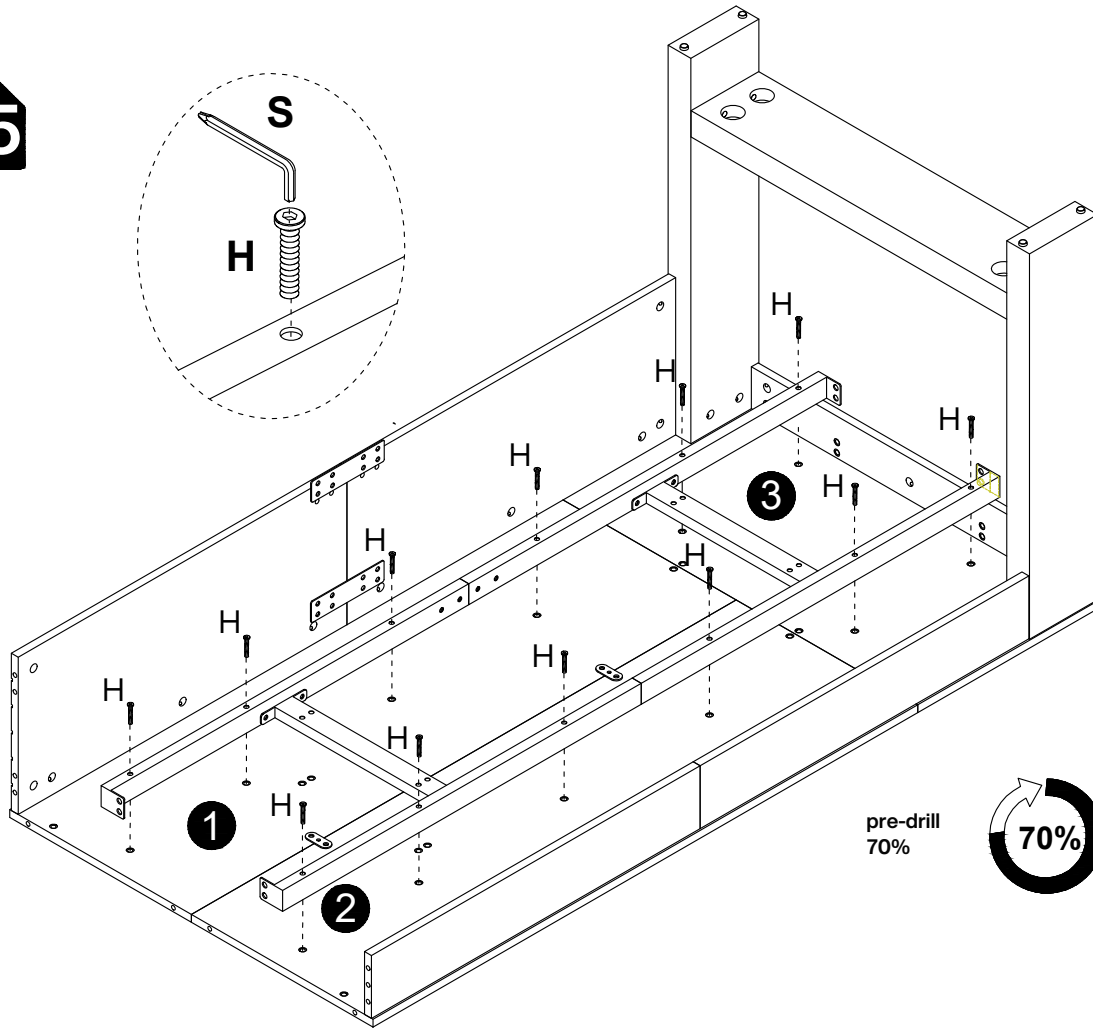

H

M6x50mm
12 pcs



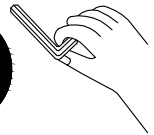

pre-drill
70%

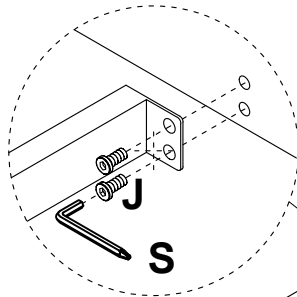

26



I

M6x30mm
8 pcs

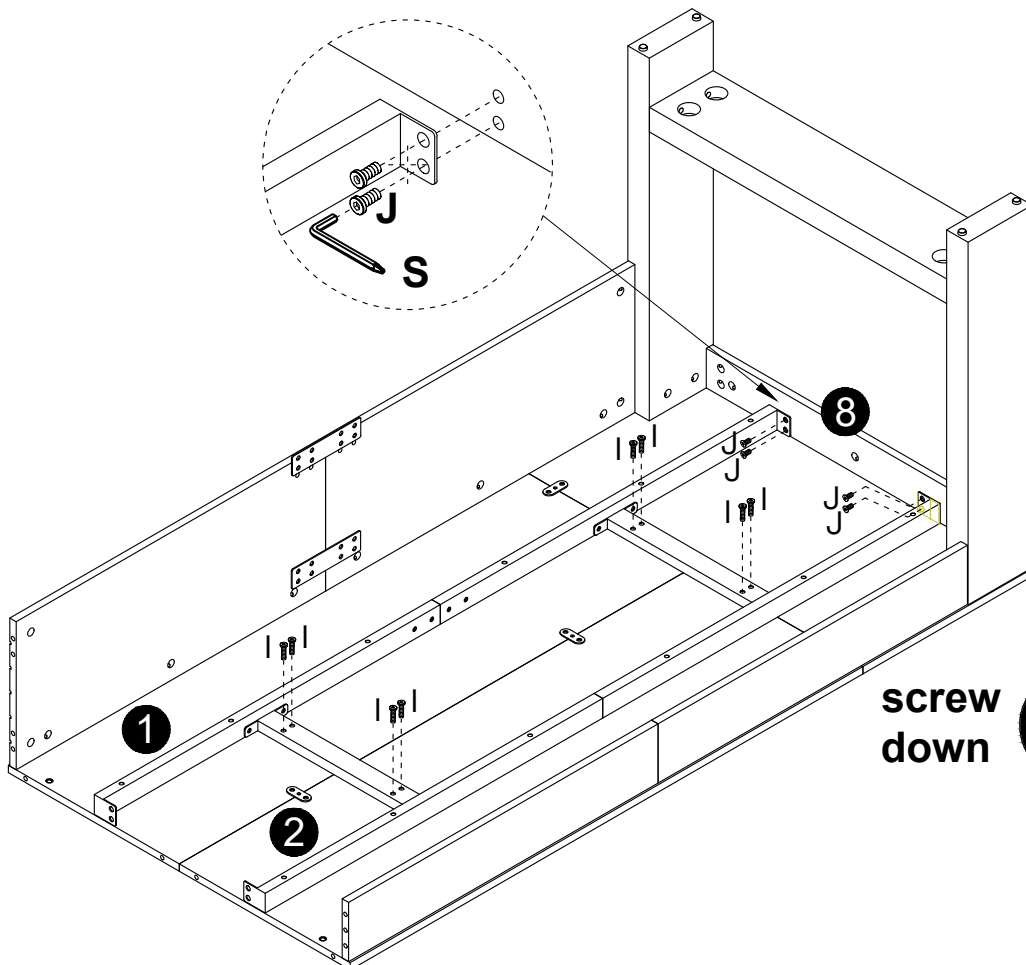
J

M6x12mm
4 pcs

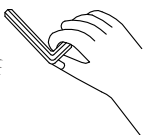



screw
down

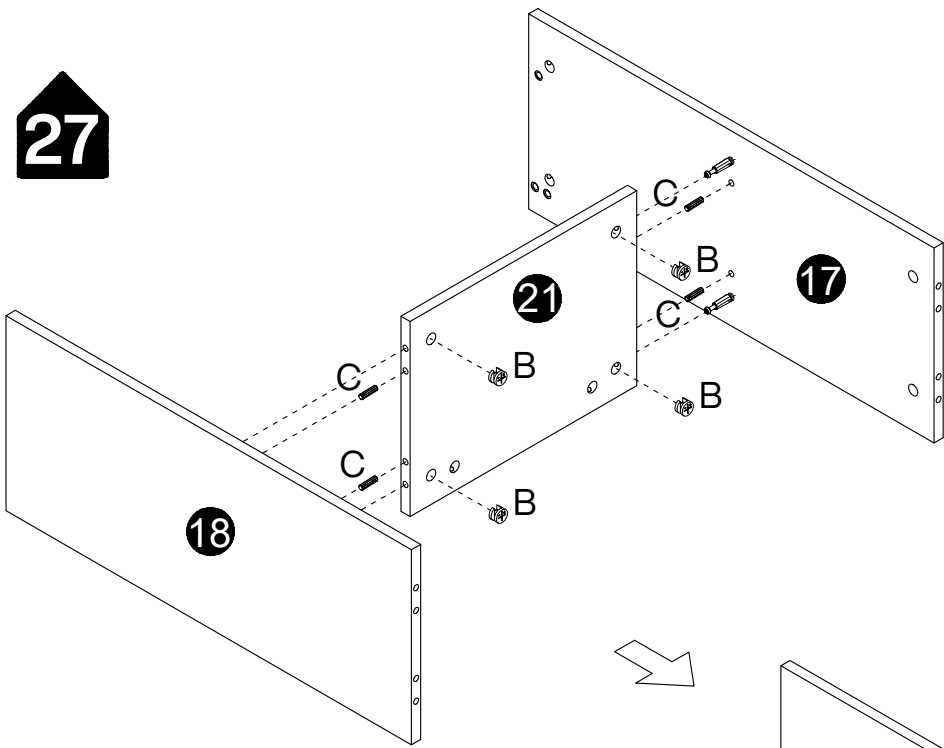

27



B	C
	
Ø15x12mm	Ø8x30mm
4 pcs	4 pcs

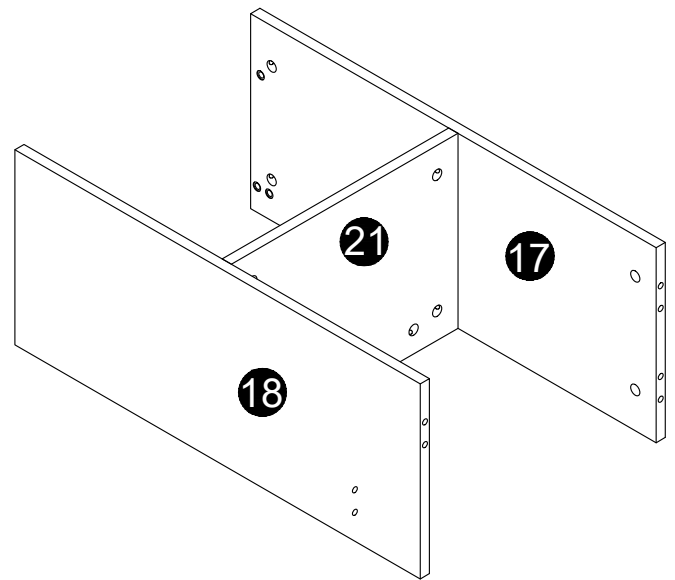

28

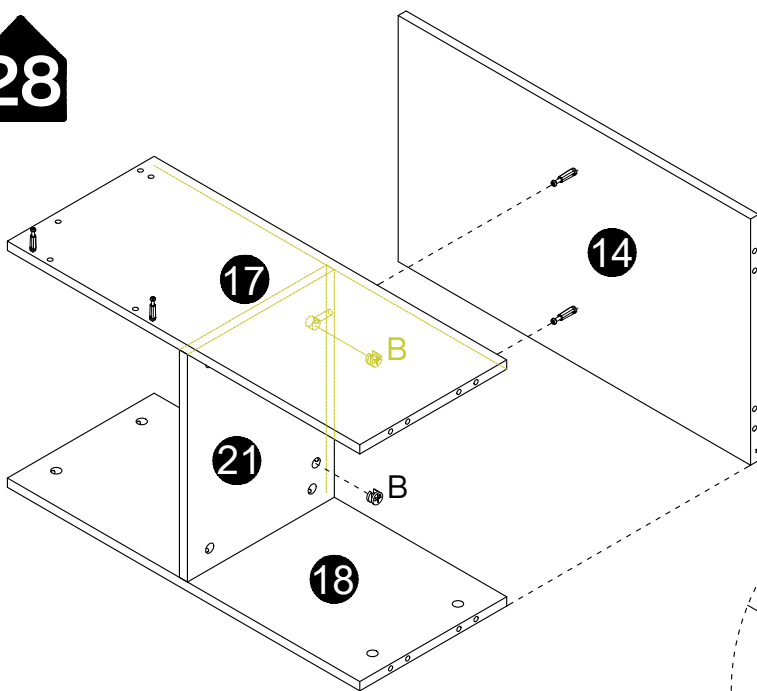

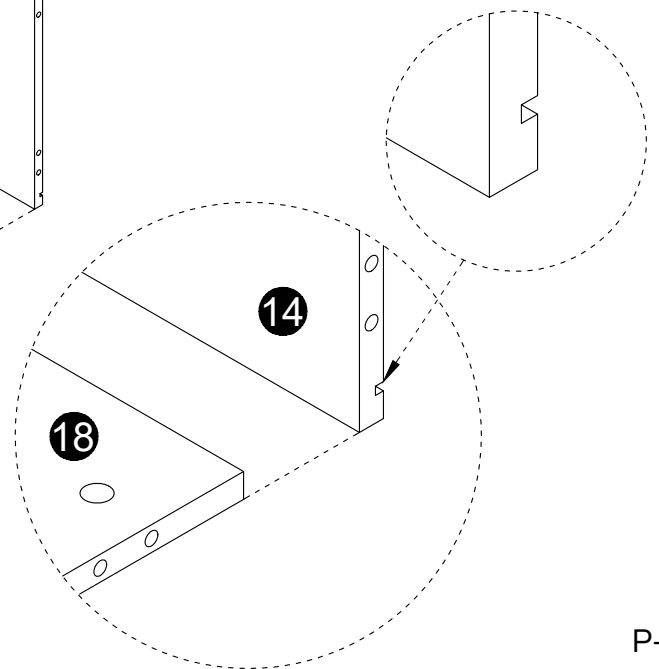

B

Ø15x12mm
2 pcs

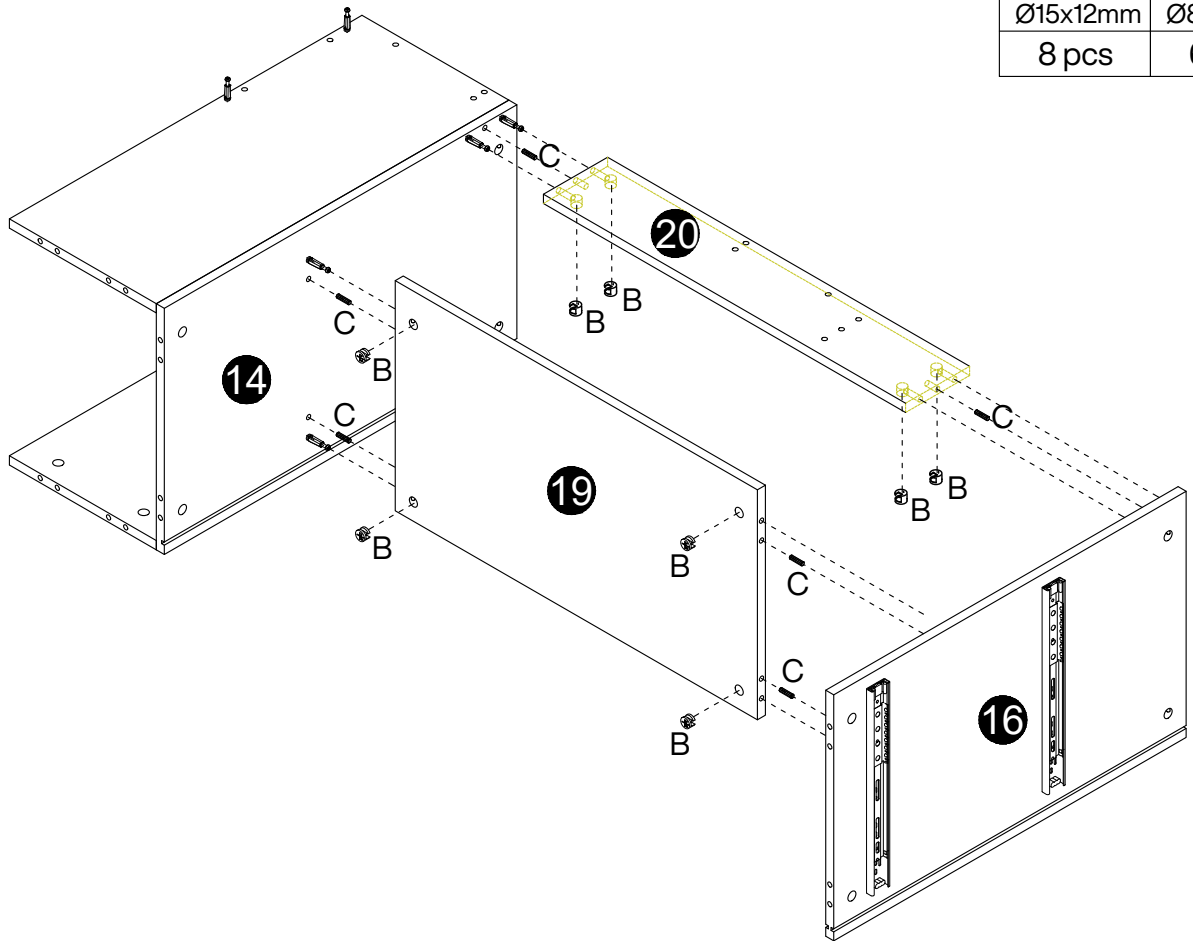



29

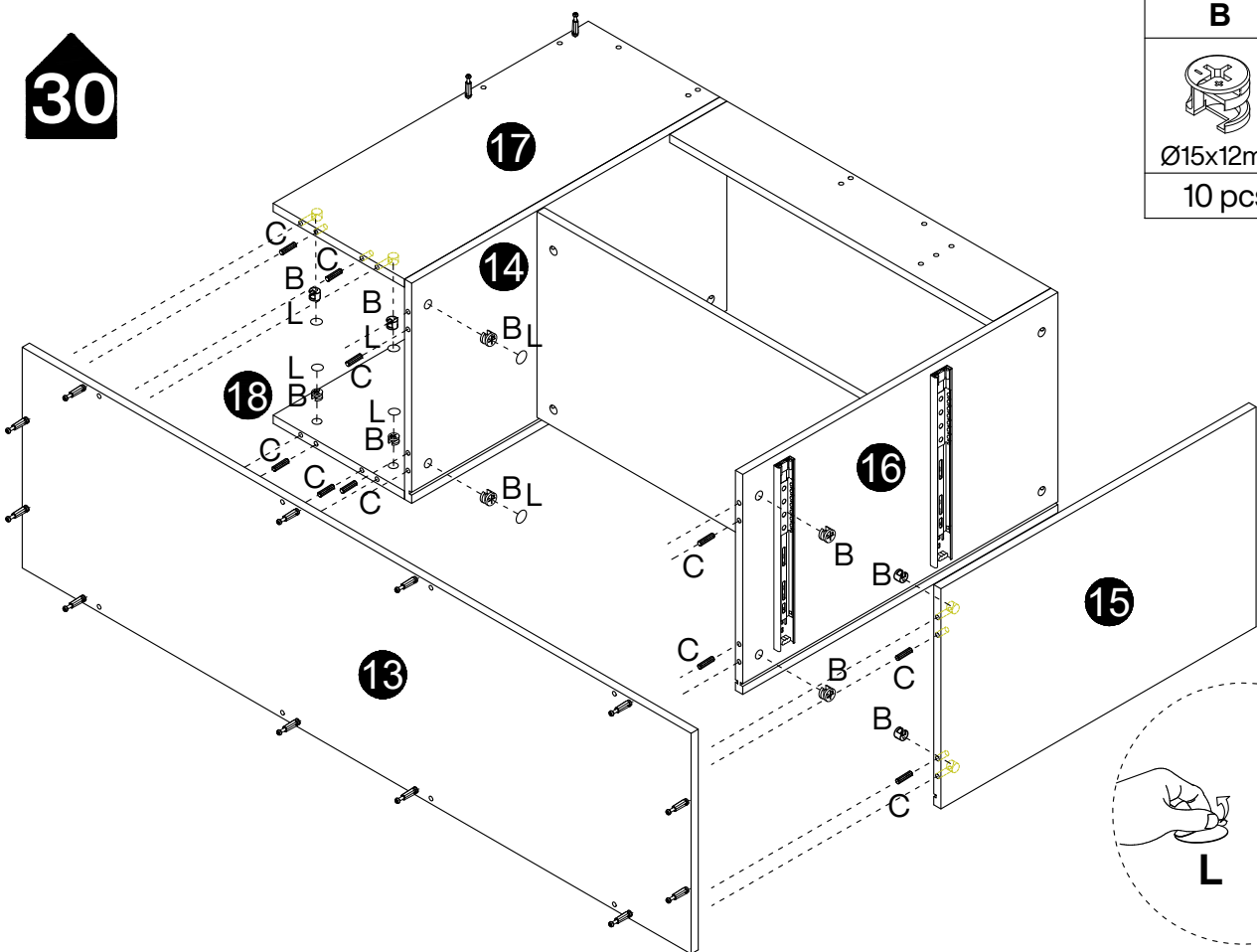

B	C
	
Ø15x12mm	Ø8x30mm
8 pcs	6 pcs

30



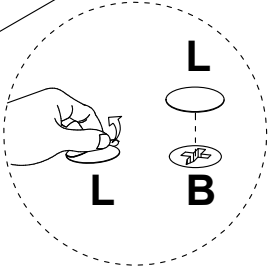

B	C
	
Ø15x12mm	Ø8x30mm
10 pcs	10 pcs

L

Ø21mm
6 pcs

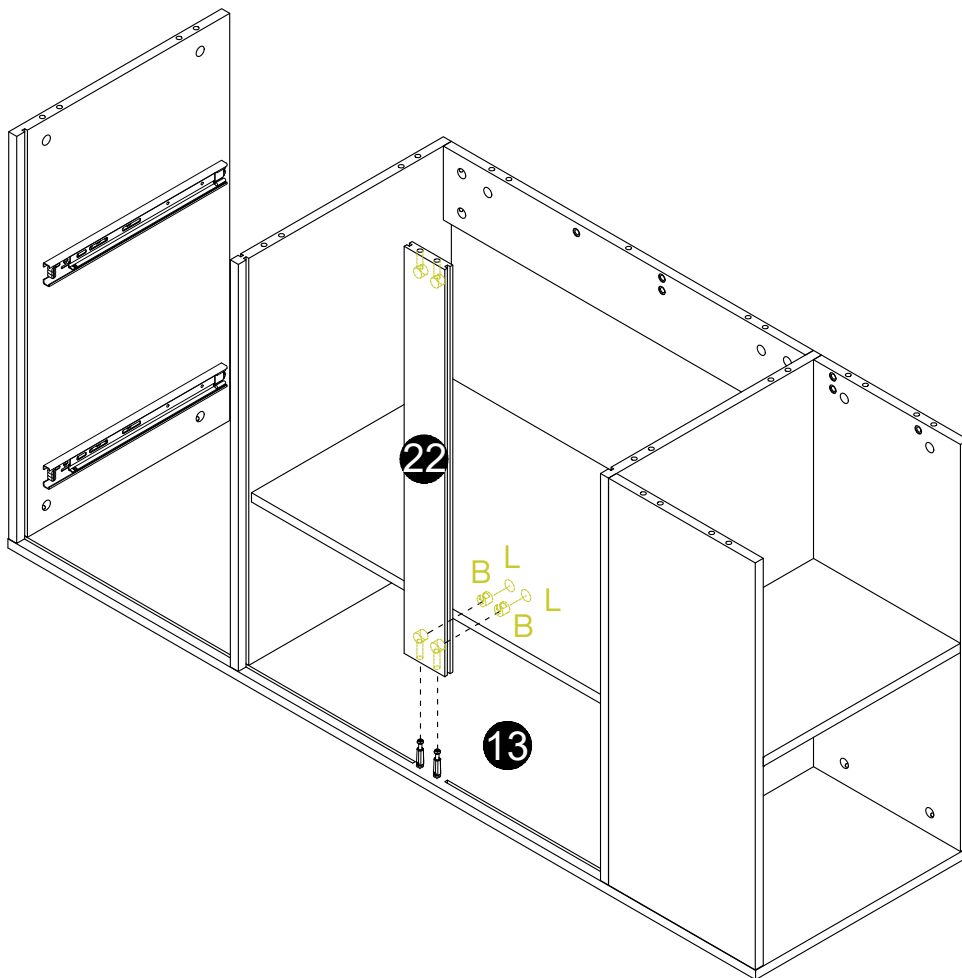

31



B

Ø15x12mm
2 pcs

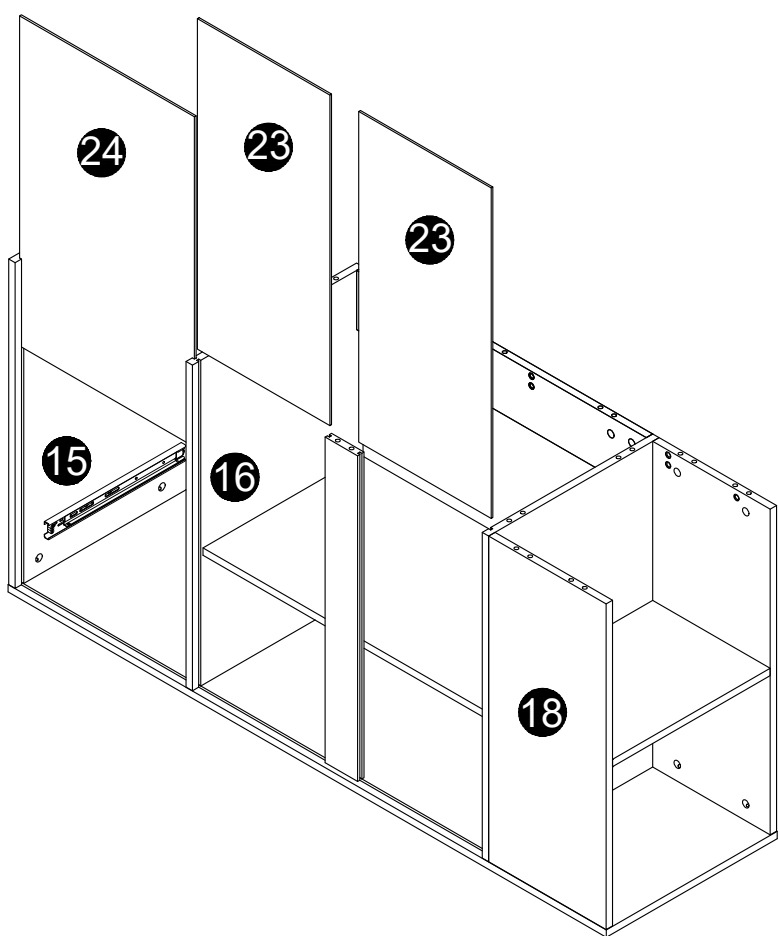

L

Ø21mm
2 pcs

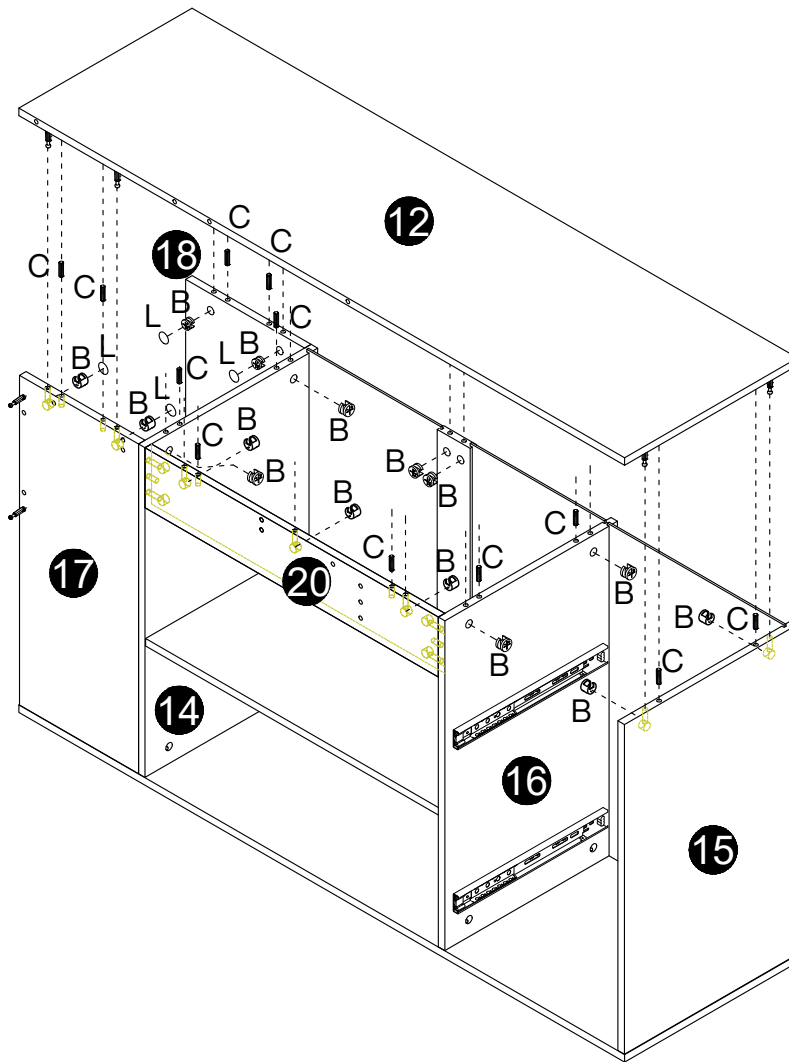
32



33



B	C
	
Ø15x12mm	Ø8x30mm
15 pcs	12 pcs

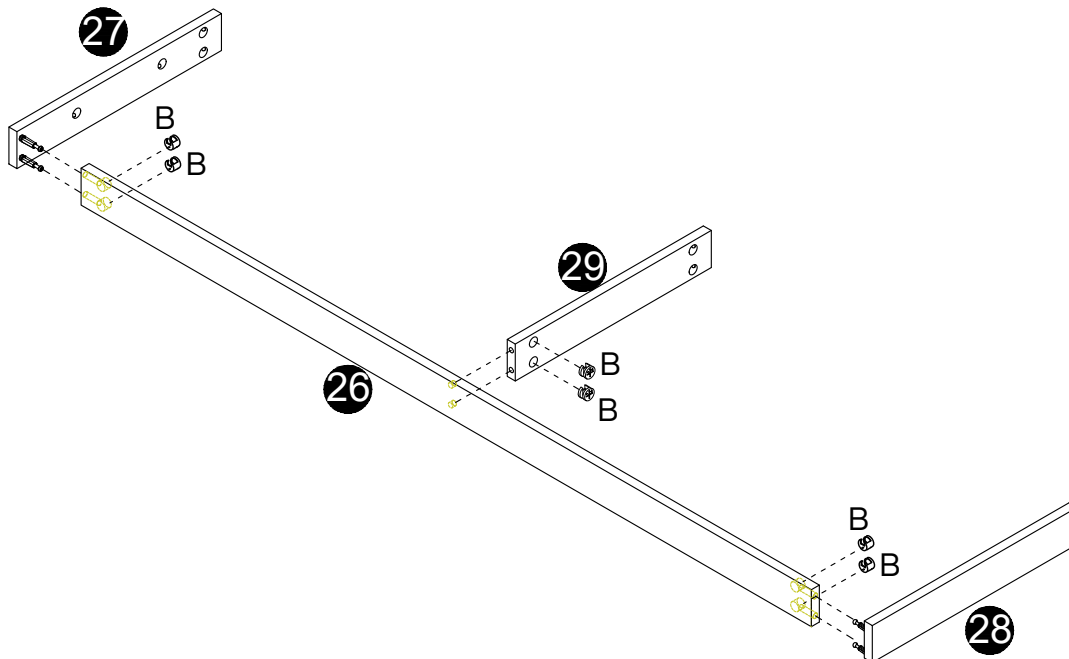

L

Ø21mm
4 pcs

34



B

Ø15x12mm
6 pcs

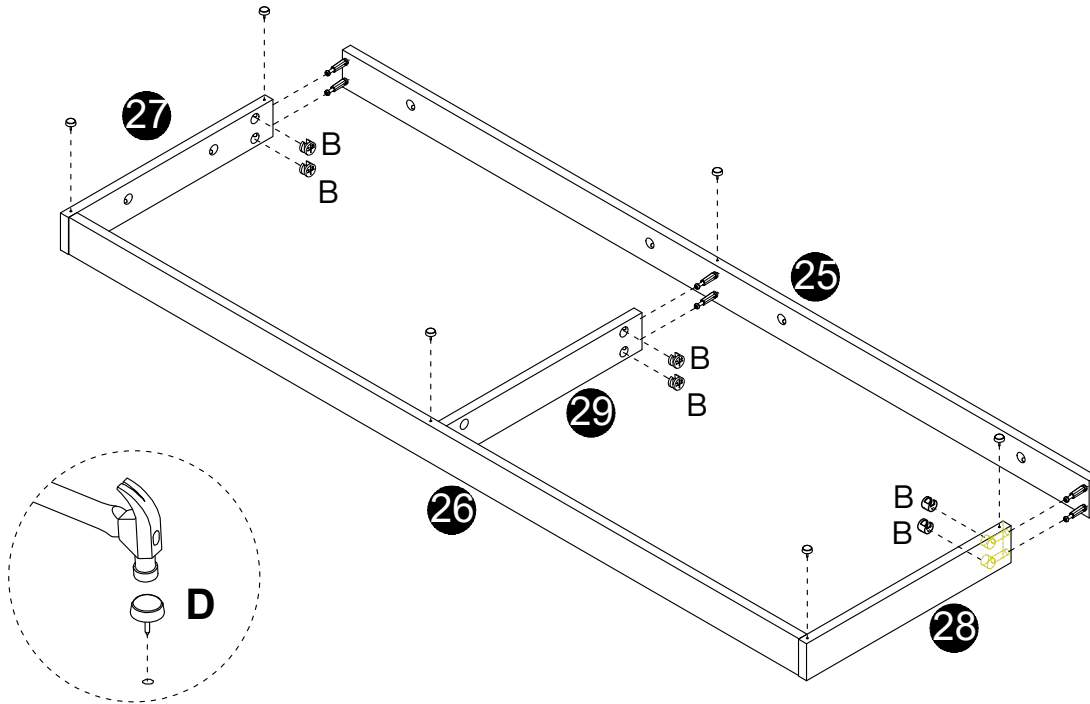

35

B	R
 Ø15x12mm	
6 pcs	6 pcs





⚠ Caution! Tap lightly

36

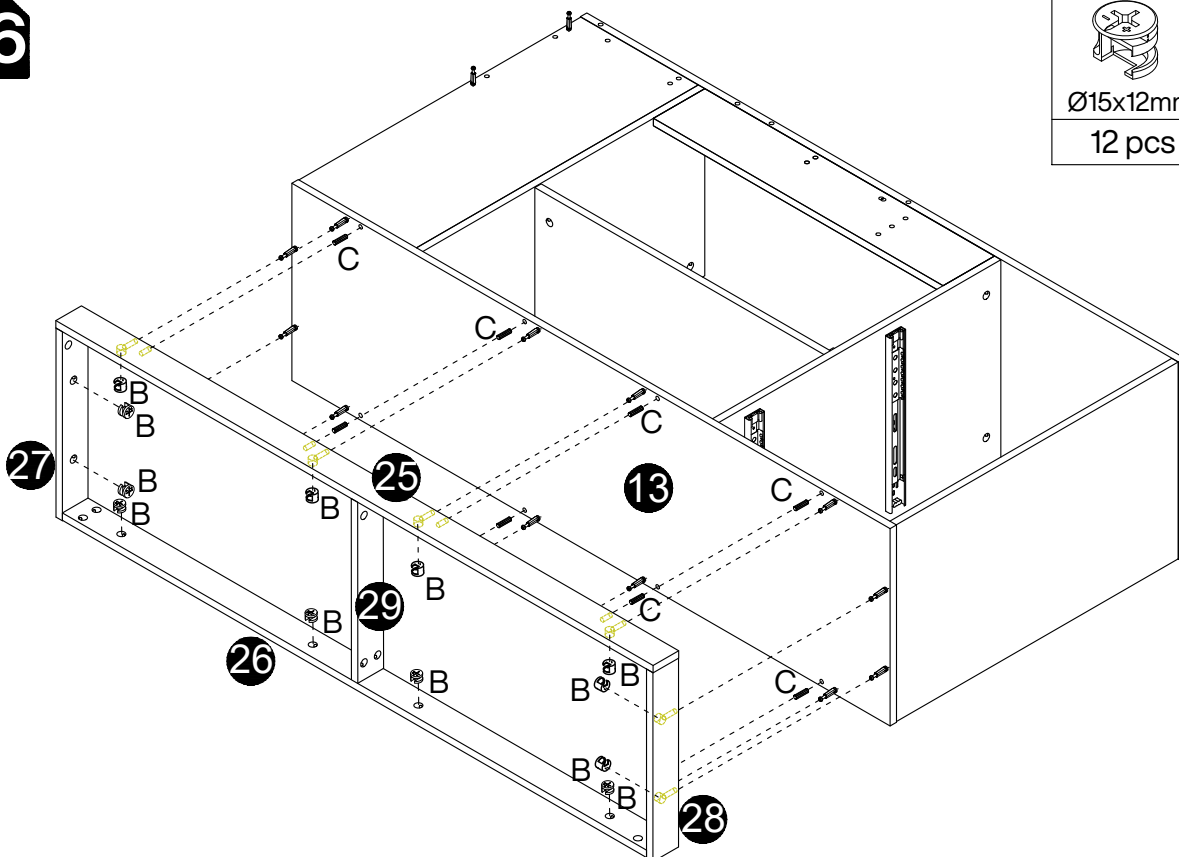
B	C
 Ø15x12mm	 Ø8x30mm
12 pcs	8 pcs



37

K	G
	
14 pcs	3x18mm 14 pcs

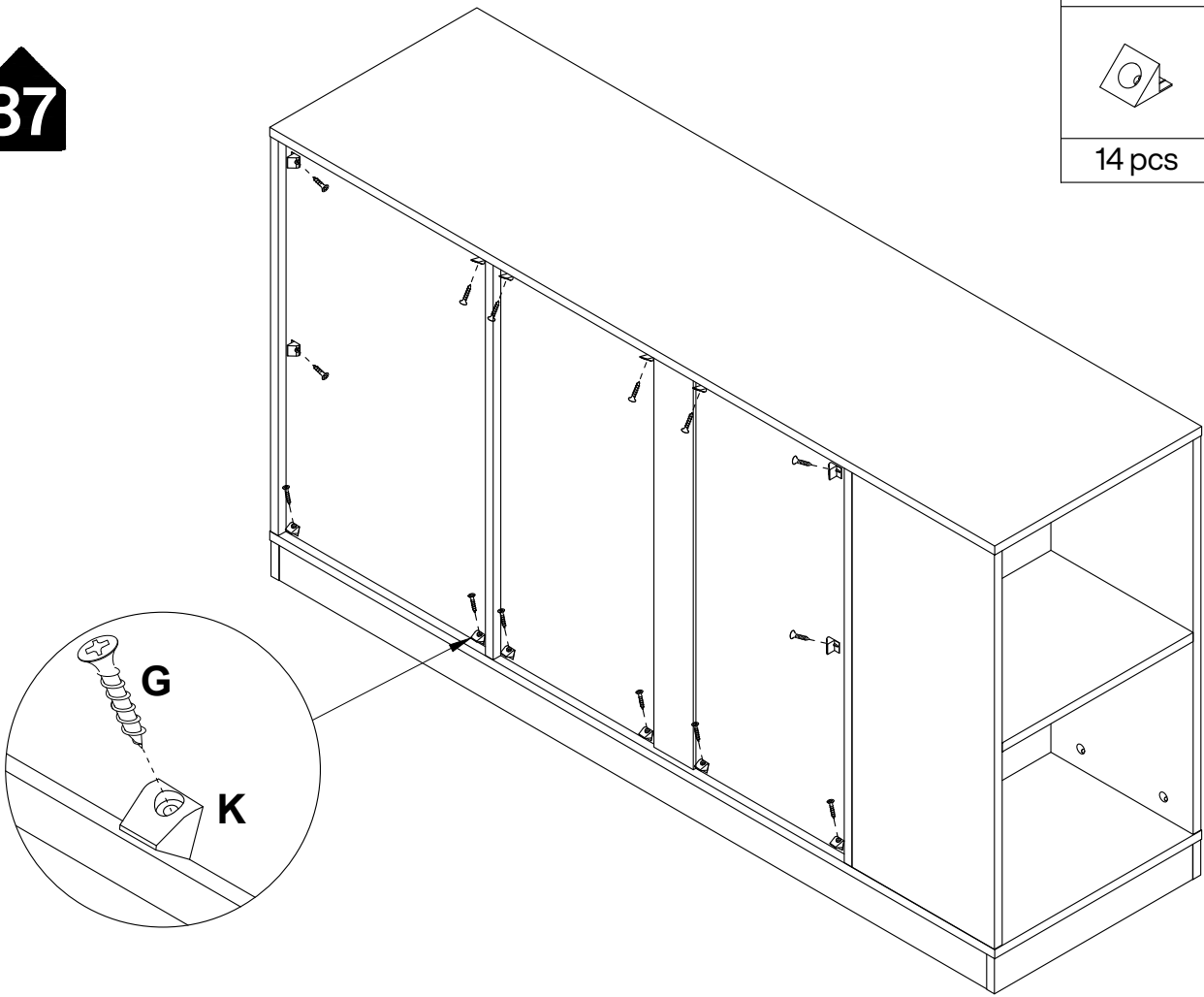



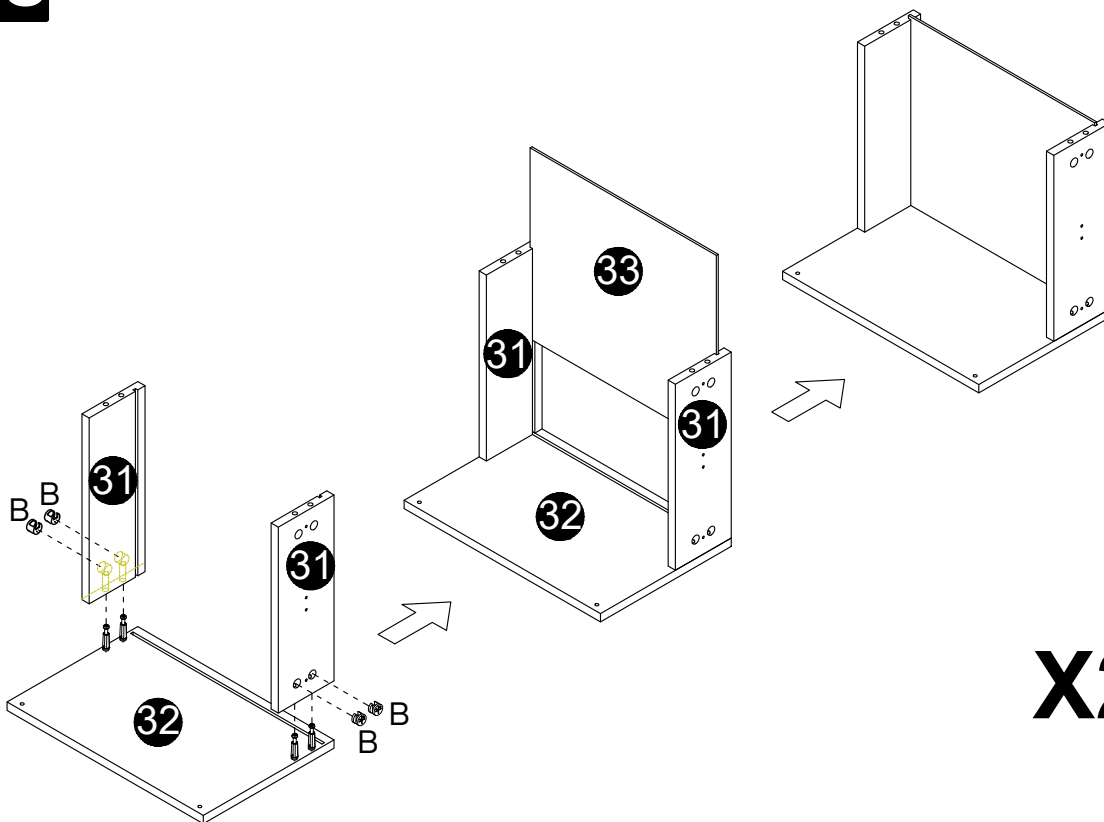

38

B

Ø15x12mm
8 pcs



X2

39

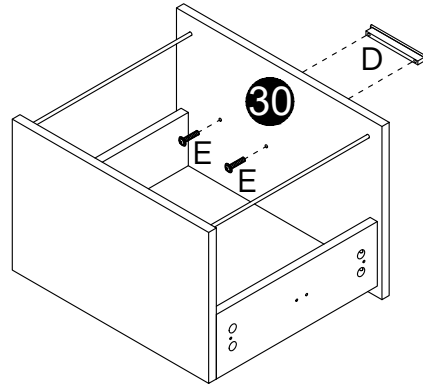
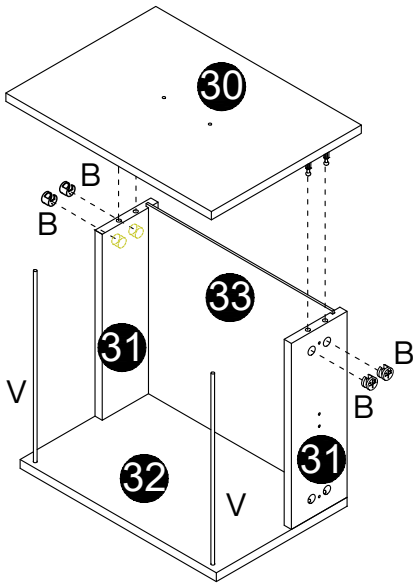

B	D	E	V
 Ø15x12mm			 Ø5x355mm
8 pcs	2 pcs	4 pcs	4 pcs

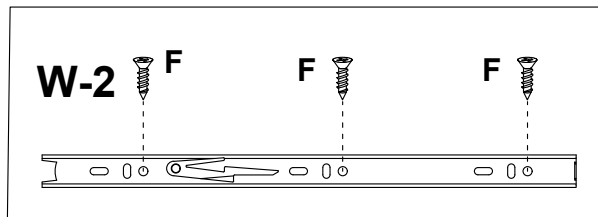

X2

40



F	W-2
 3.5x14mm	 340mm
12 pcs	4 pcs

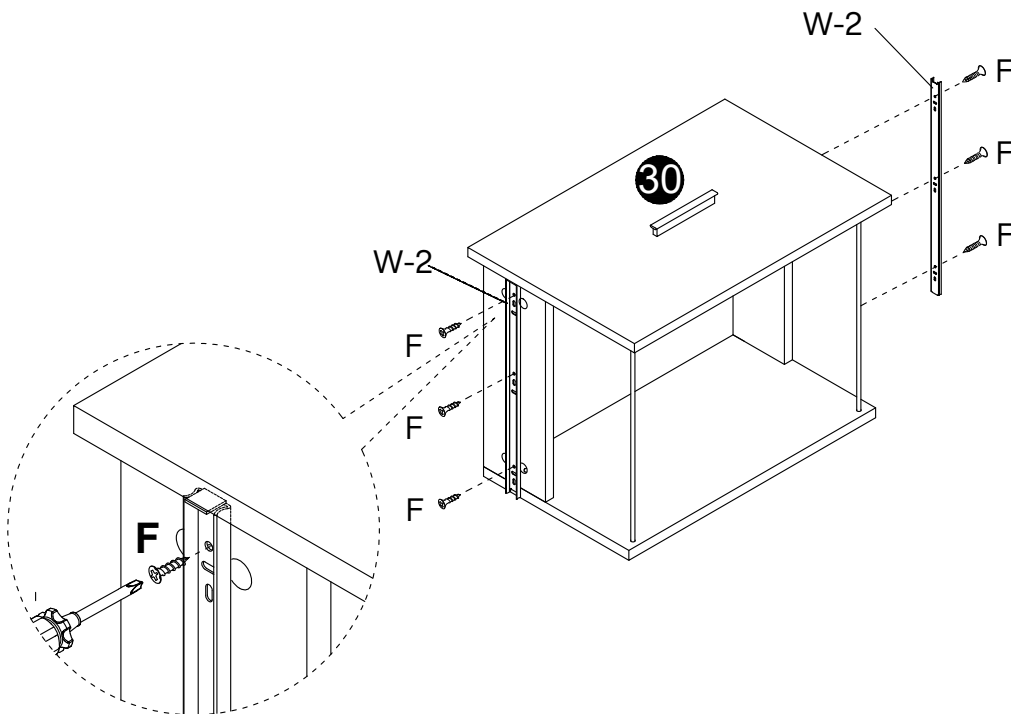

X2

41

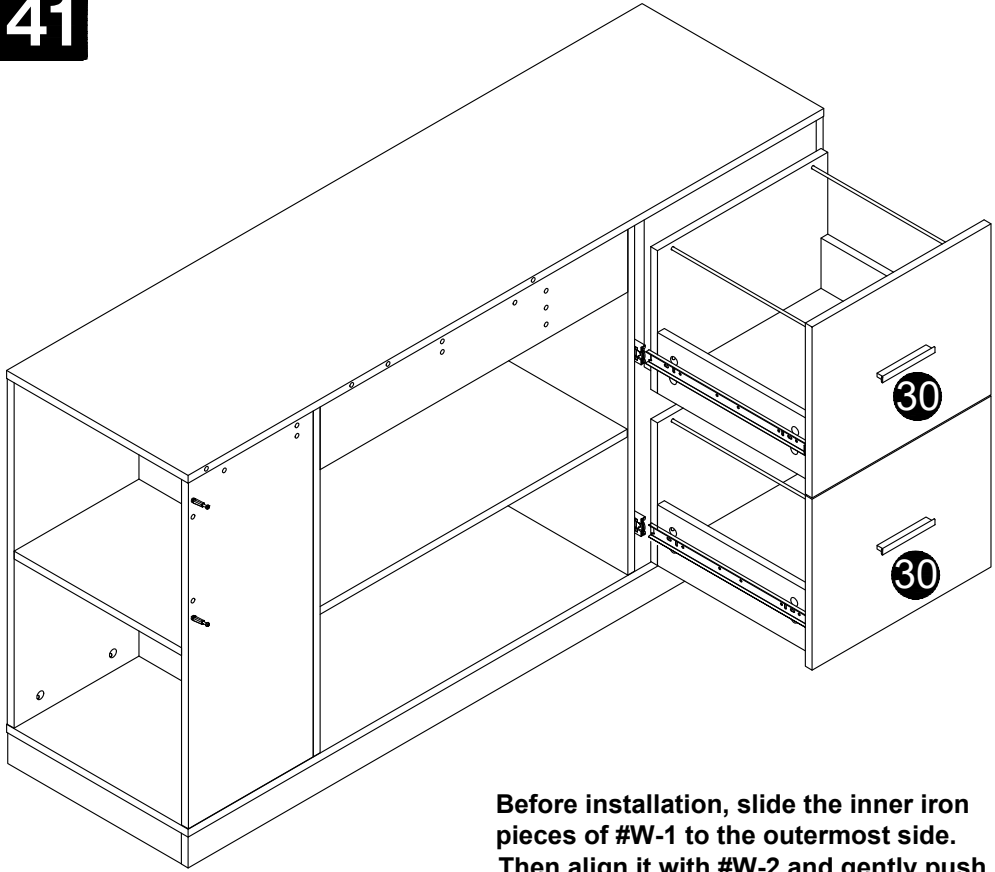

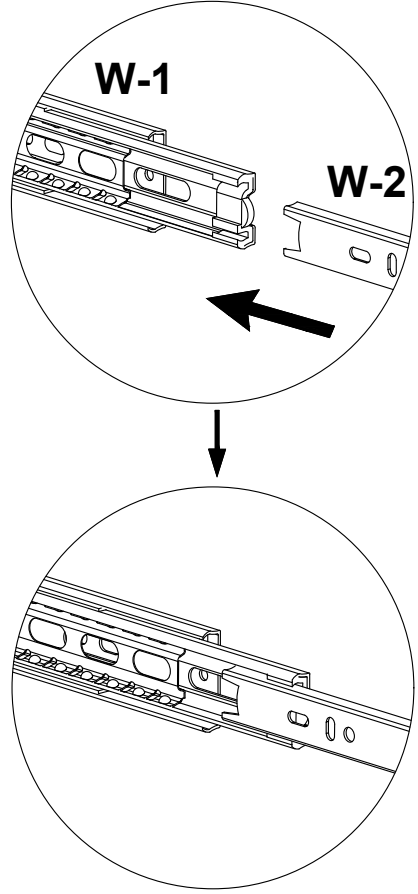

Before installation, slide the inner iron pieces of #W-1 to the outermost side. Then align it with #W-2 and gently push it inward to complete the slide installation.

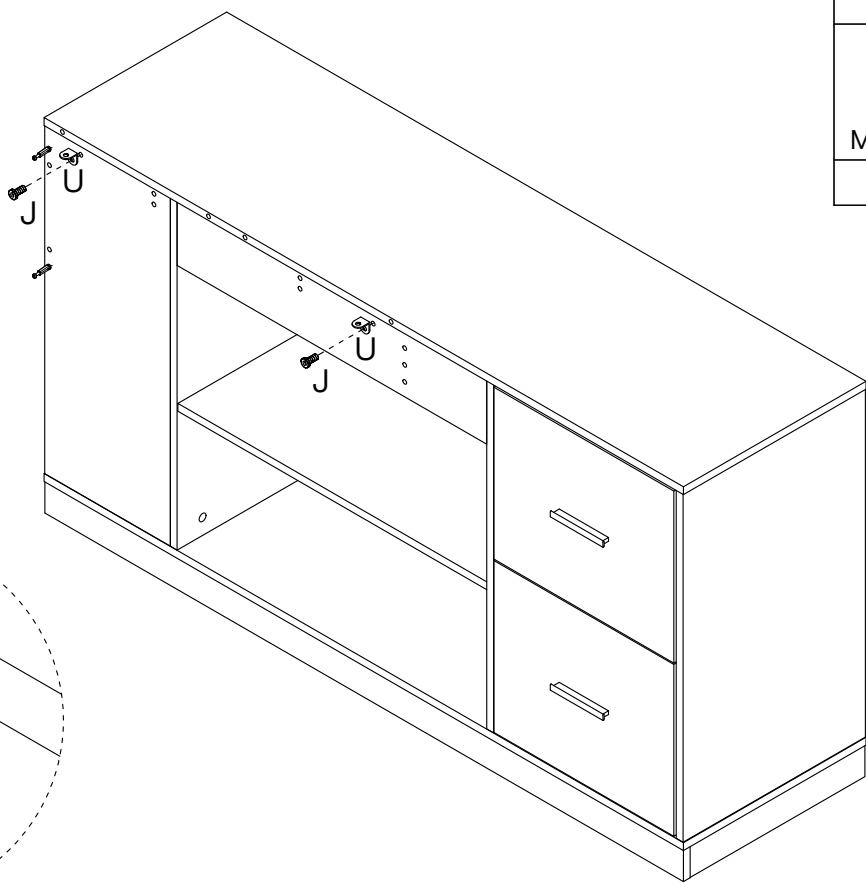

42





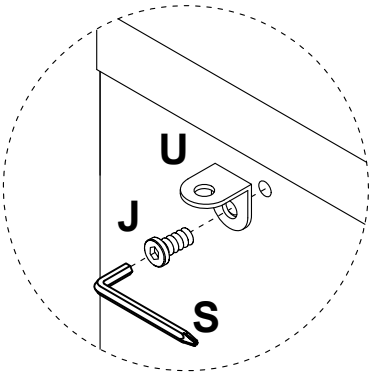

J	S
	
M6x12mm	M4
2 pcs	1 pc

U

2 pcs



43

B	C	J	S
			
Ø15x12mm	Ø8x30mm	M6x12mm	M4
4 pcs	7 pcs	6 pcs	1 pc

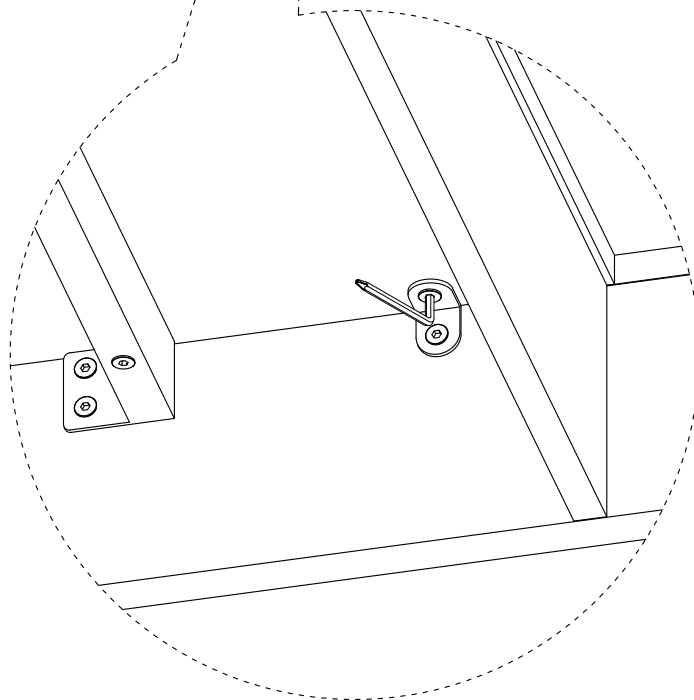
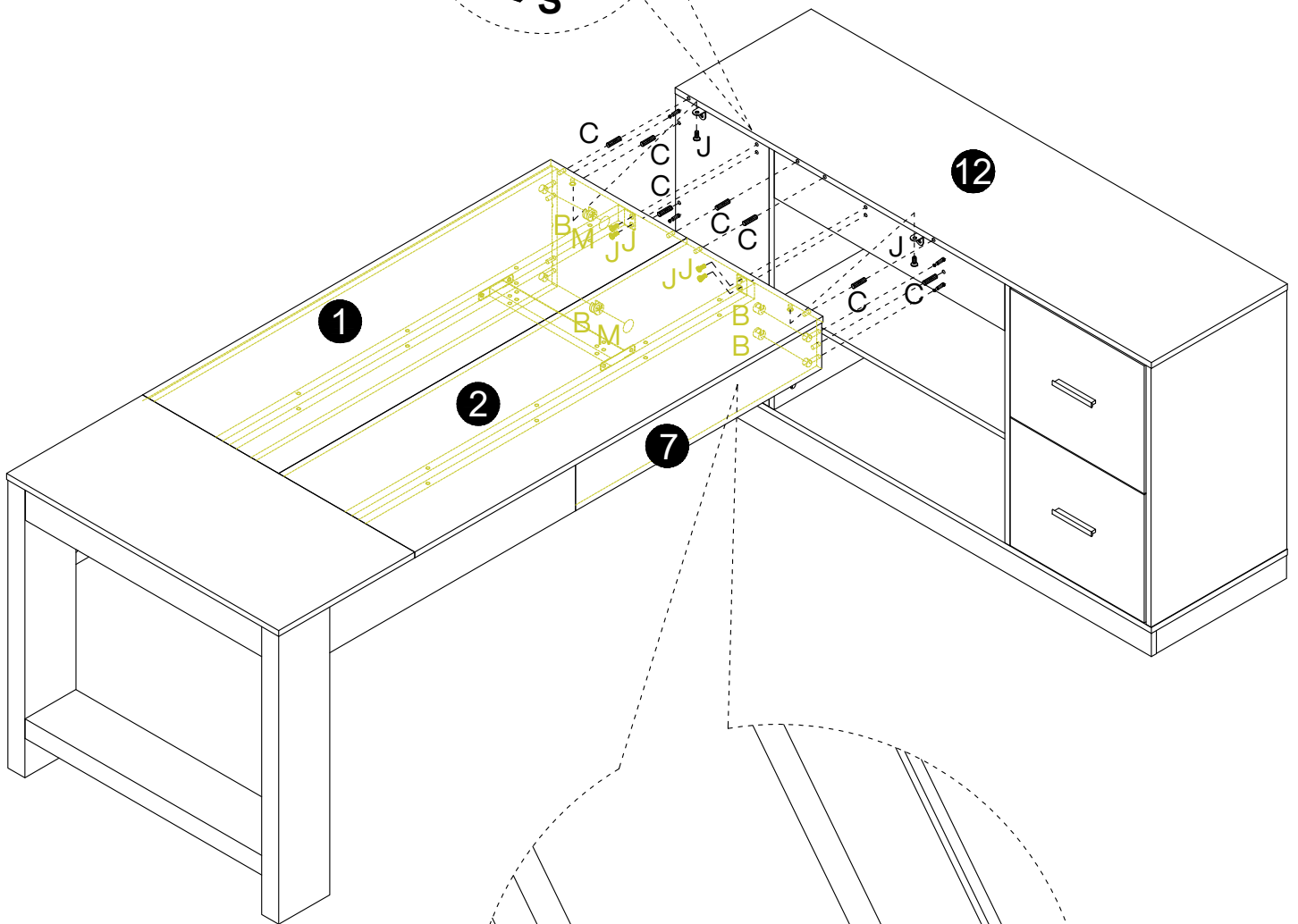
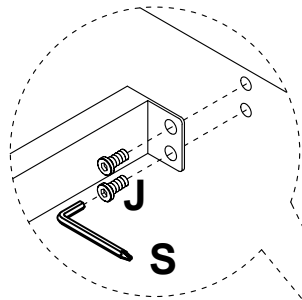
M

Ø21mm
2 pcs



Thank you for your support!

