

Assembly Instructions

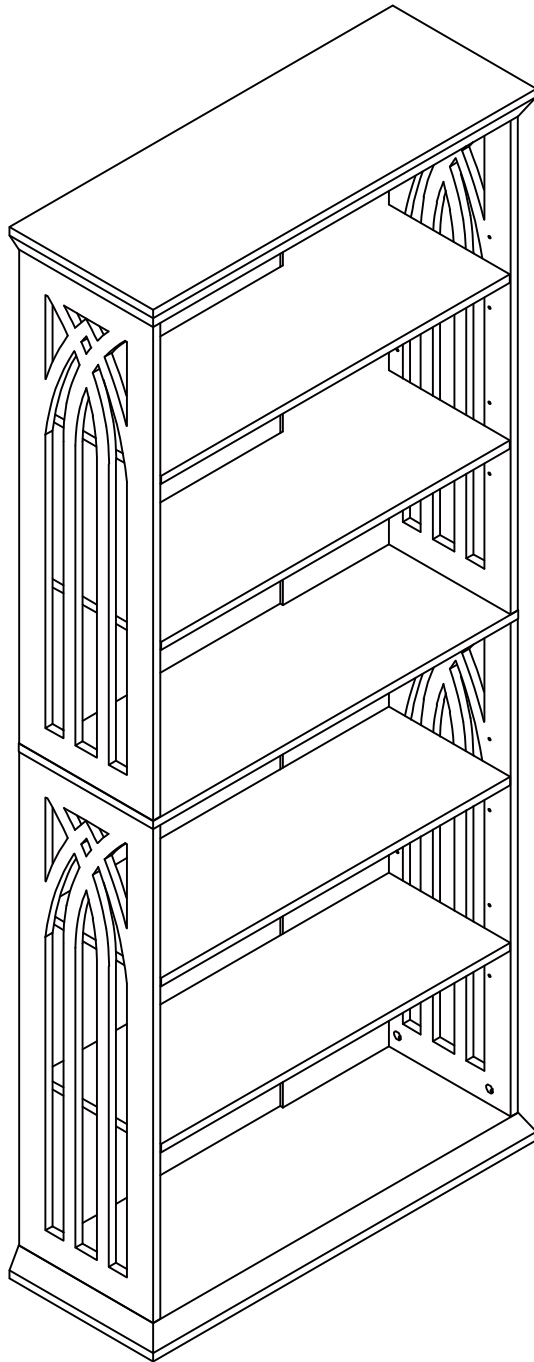

Bookshelf

Model No.
HOGA-F2161
HOGA-F2259

Contact Us

We're here to help you.



Your satisfaction is our top priority. If you encounter any issues with this product, such as missing or damaged parts, we're here to help. Please retain the original packaging and take photos of the packaging and the product, then contact us as soon as possible.

Warm Tips

1. Carefully read these instructions and keep them for future reference.
2. Check the parts list and confirm everything's there before starting assembly.
3. When assembling, put all parts on a soft, smooth surface like a carpet to avoid scratches.
4. Don't fully tighten screws until all parts are confirmed in place to avoid misalignment.

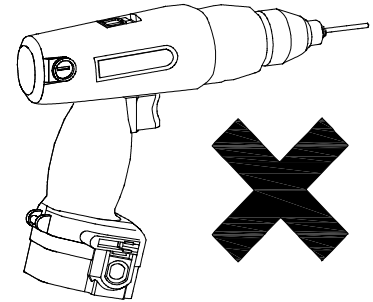
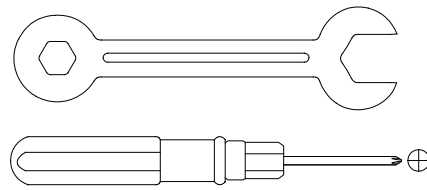
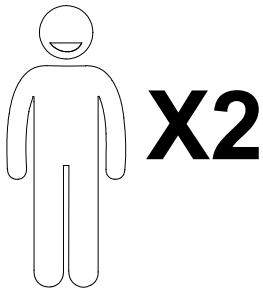

We recommend using hand tools for assembly.

If an electric screwdriver is used, reduce power and torque to avoid damage to the product.

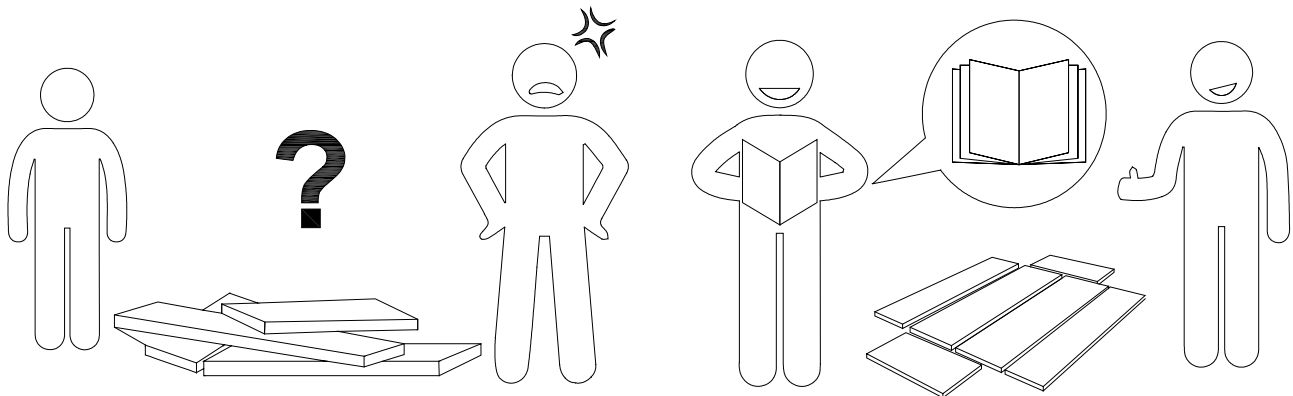

Install the Anti-Tip Straps

Using the anti-tip straps can reduce the risk of tipping over, but can not eliminate it.

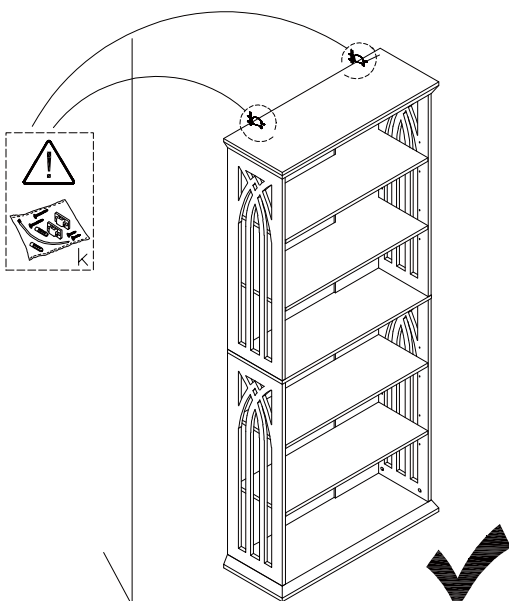

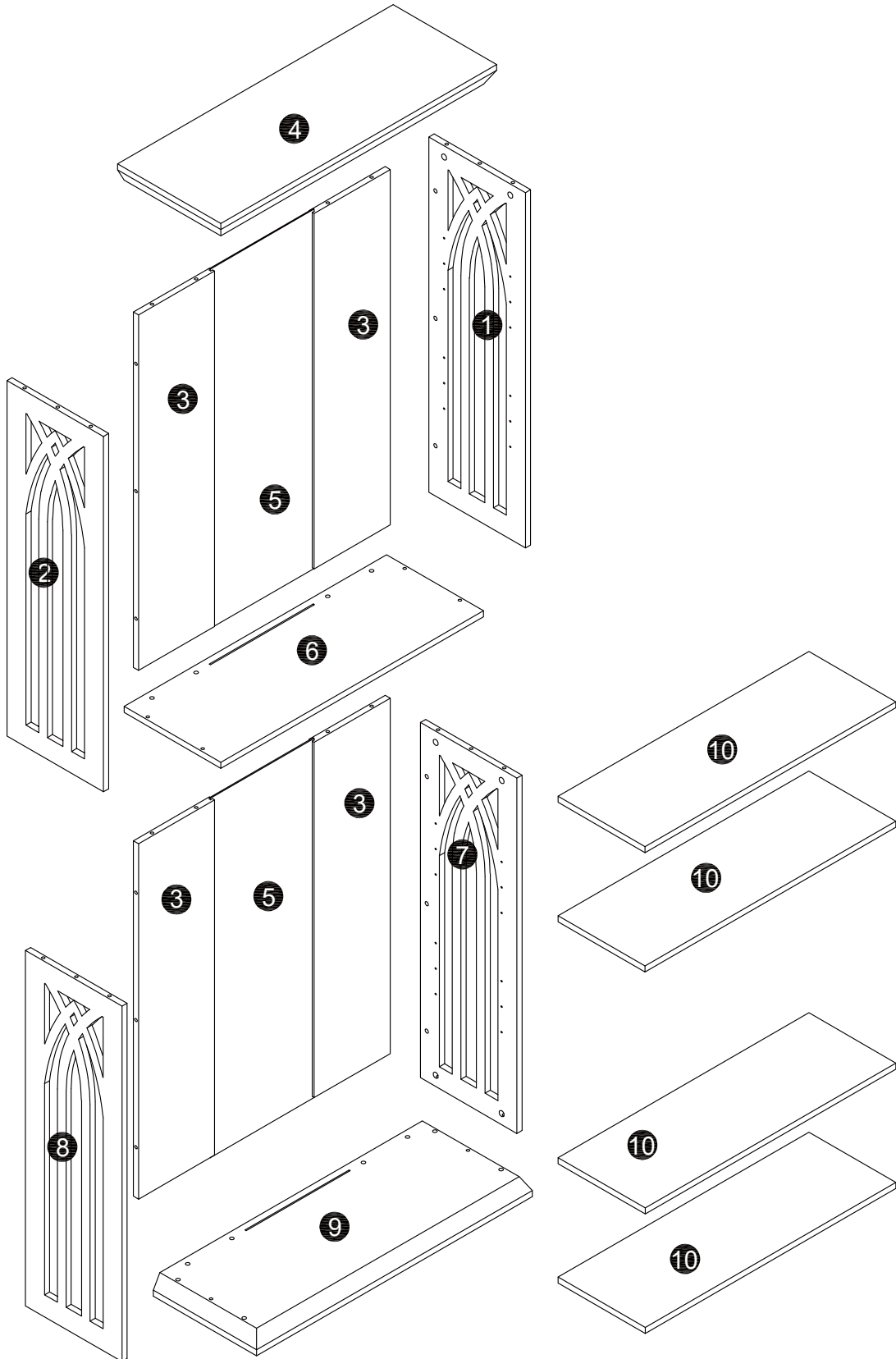



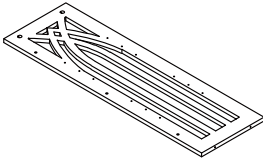
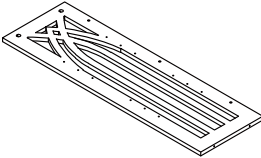
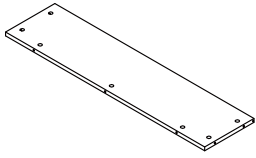
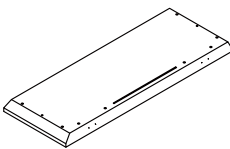
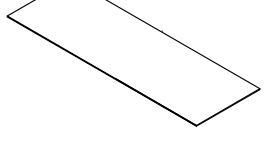
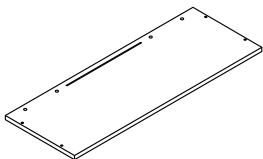
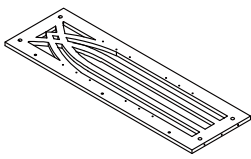
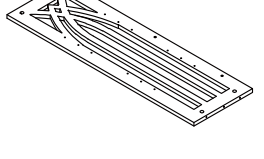
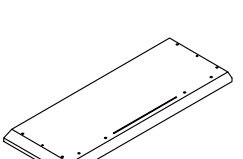
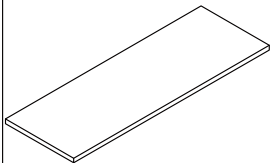

⚠ Caution

Make sure all parts are included. Most board parts are labeled or stamped on the raw edge. Contact us for a free replacement if you encounter any damaged or missing parts.

Parts List

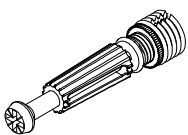
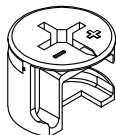
 <p>1 pc</p>	 <p>1 pc</p>	 <p>4 pcs</p>	 <p>1 pc</p>	 <p>2 pcs</p>
 <p>1 pc</p>	 <p>1 pc</p>	 <p>1 pc</p>	 <p>1 pc</p>	 <p>4 pcs</p>

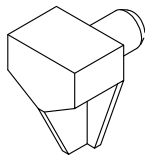
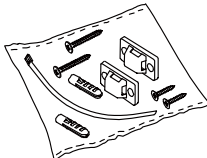
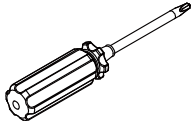
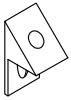
Hardware List

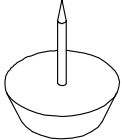
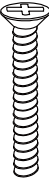
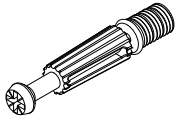
 <p>M6X35mm</p> <p>32 pcs</p>	 <p>Ø15x12mm</p> <p>40 pcs</p>	 <p>Ø8x30mm</p> <p>6 pcs</p>	 <p>16 pcs</p>	 <p>2 pcs</p>	 <p>Screwdriver</p> <p>1 pc</p>
 <p>14X12X10mm</p> <p>12 pcs</p>	 <p>Ø3.5x14mm</p> <p>12 pcs</p>	 <p>8 pcs</p>	 <p>Ø7X38mm</p> <p>4 pcs</p>	 <p>M6X35mm</p> <p>8 pcs</p>	

Installation of Cams and Pins

Read each step carefully before starting. Each step of instruction should be performed in the correct order. If these steps are not followed in sequence, assembly difficulties may occur.

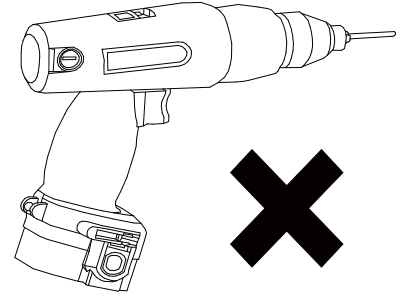

✓
No gap

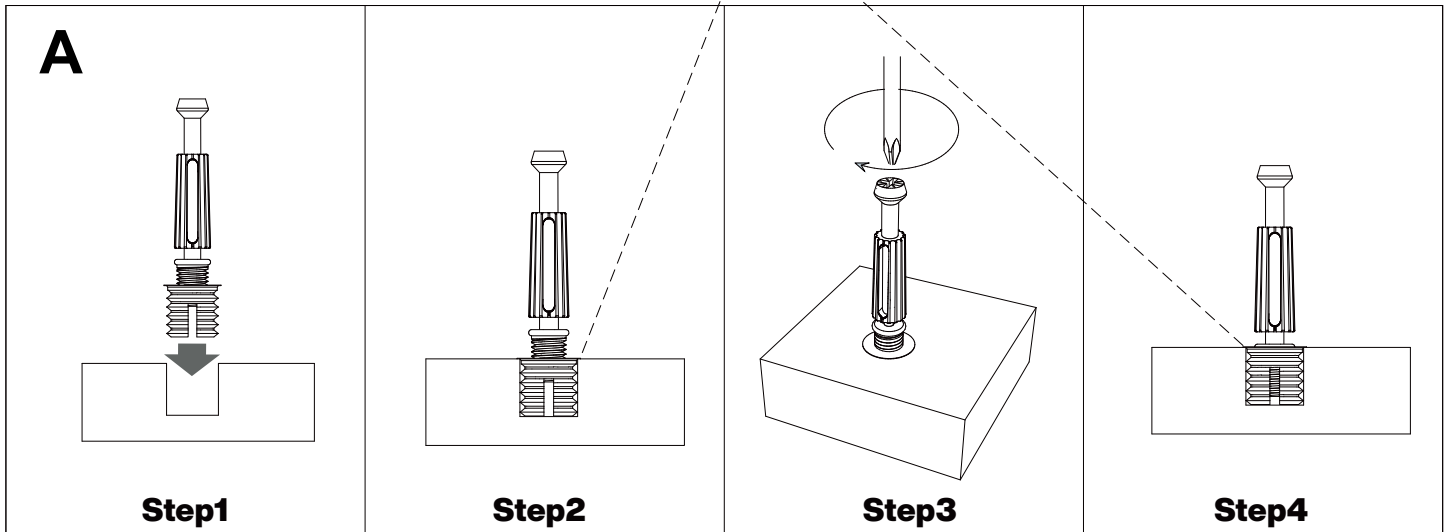

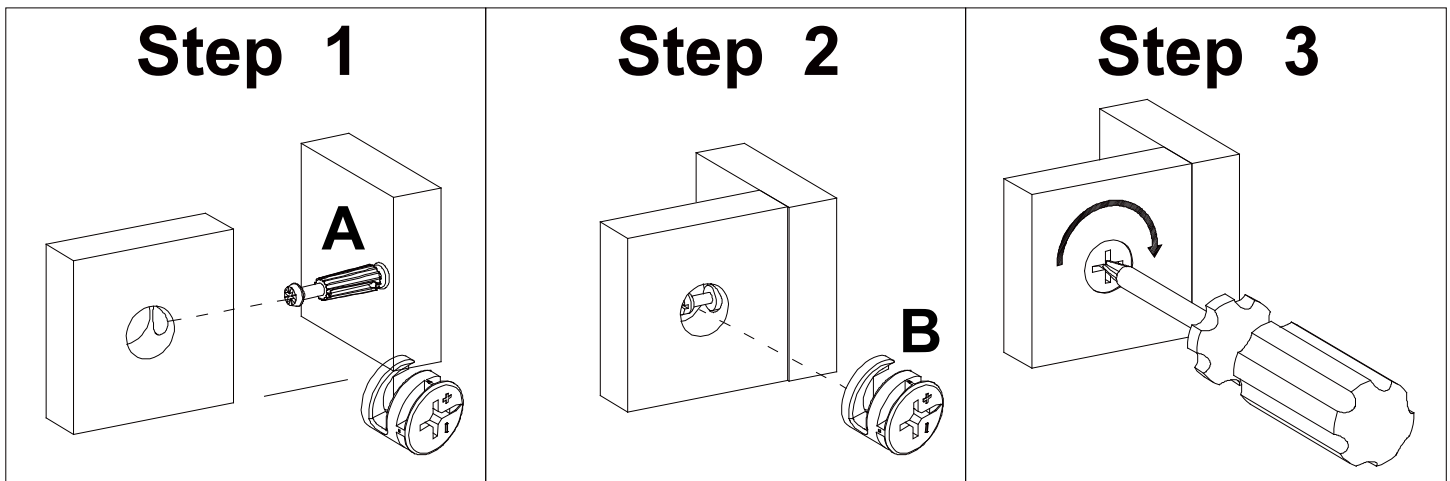

Screw the pin into the hole. Set the cams correctly by aligning the head of the cams with the lock pins. Lock the cam by turning the cam head with a screwdriver until it is tightened. Please do not use an electric screwdriver to assemble the unit.

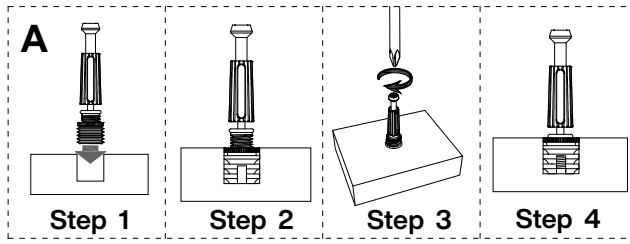

1



A	K
 M6x35mm 6 pcs	

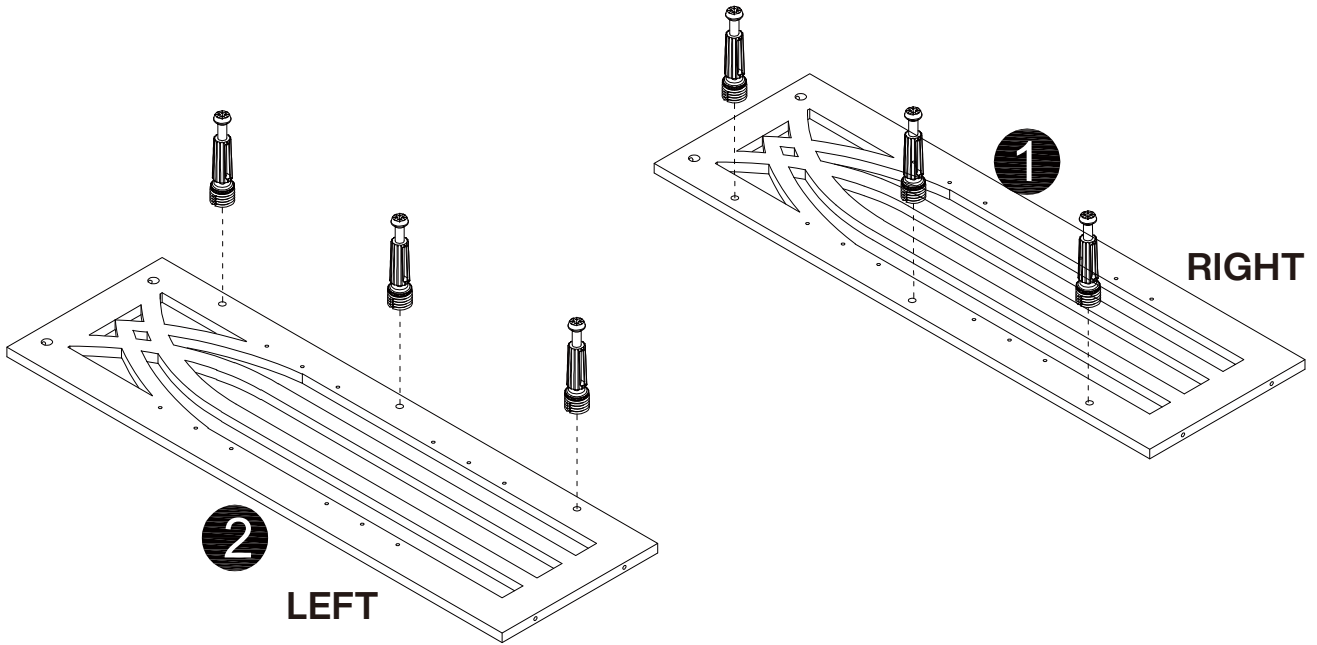

2

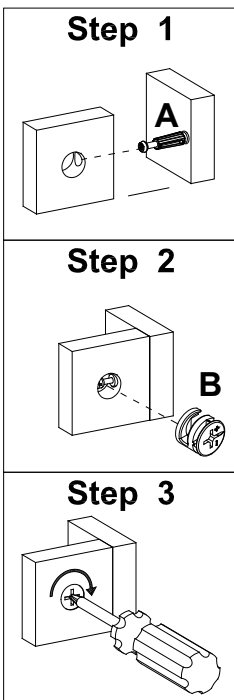

B
 Ø15x12mm 3 pcs

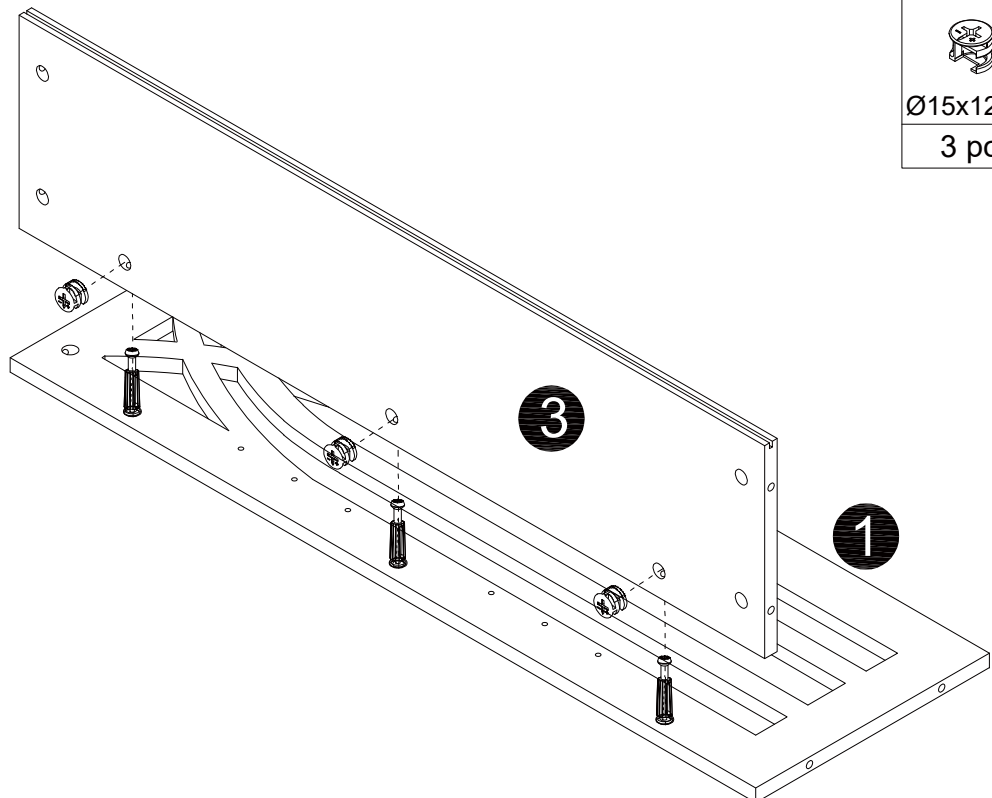

3

B

Ø15x12mm
3 pcs

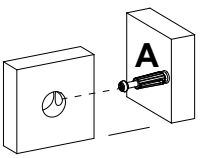
Step 1

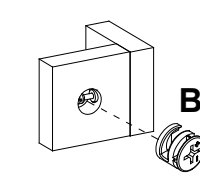

Step 2



Step 3

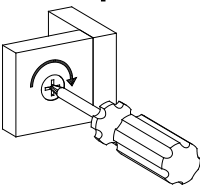
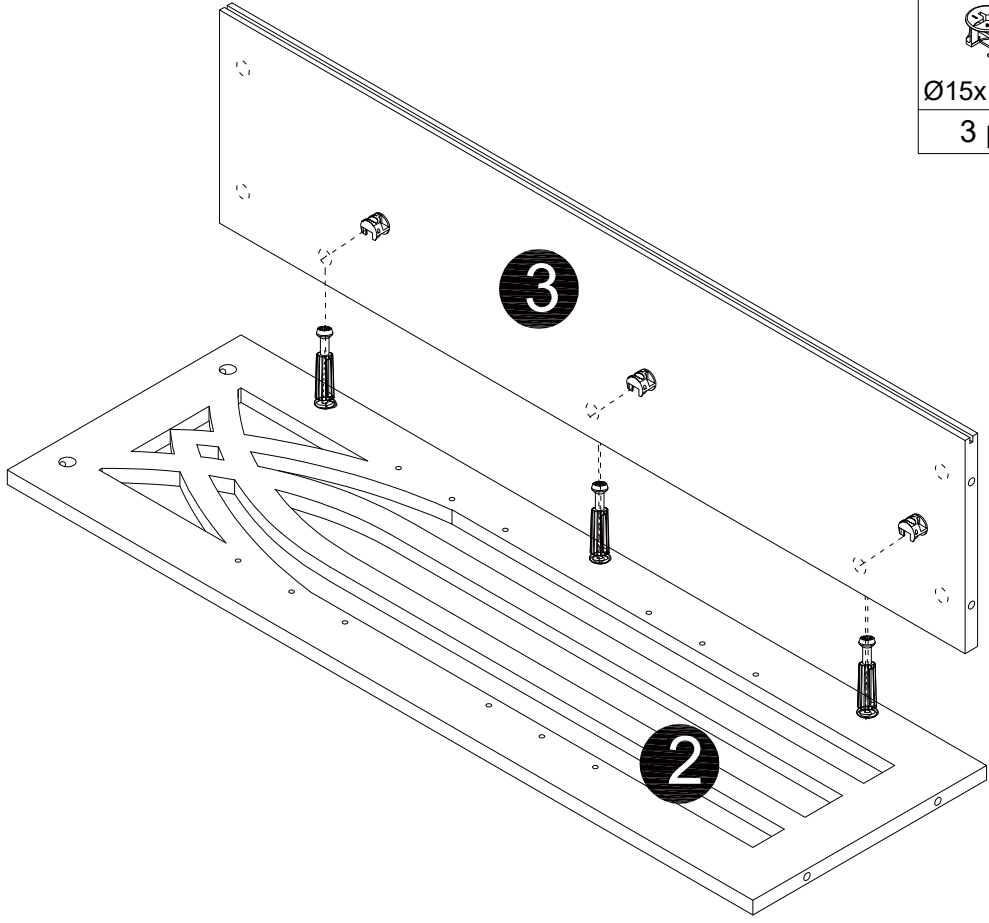

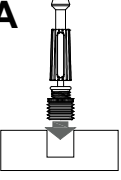

4

A

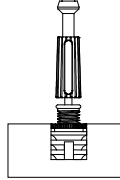

Step 1



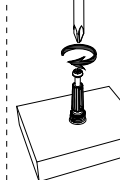

Step 2

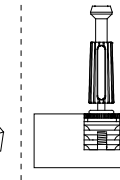

Step 3

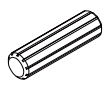

Step 4

C	A	K
		
Ø8x30mm	M6x35mm	
2 pcs	8 pcs	

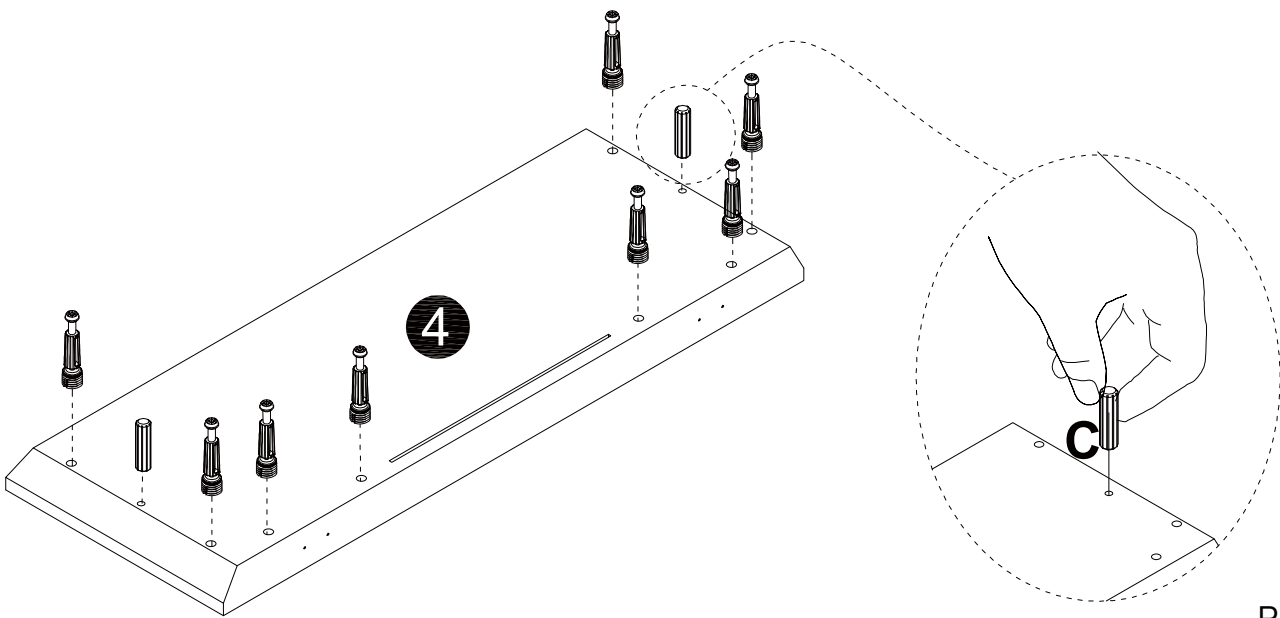

5

B

Ø15x12mm
8 pcs

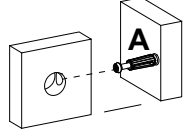
Step 1

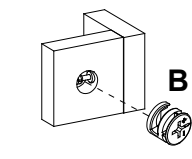

Step 2



Step 3

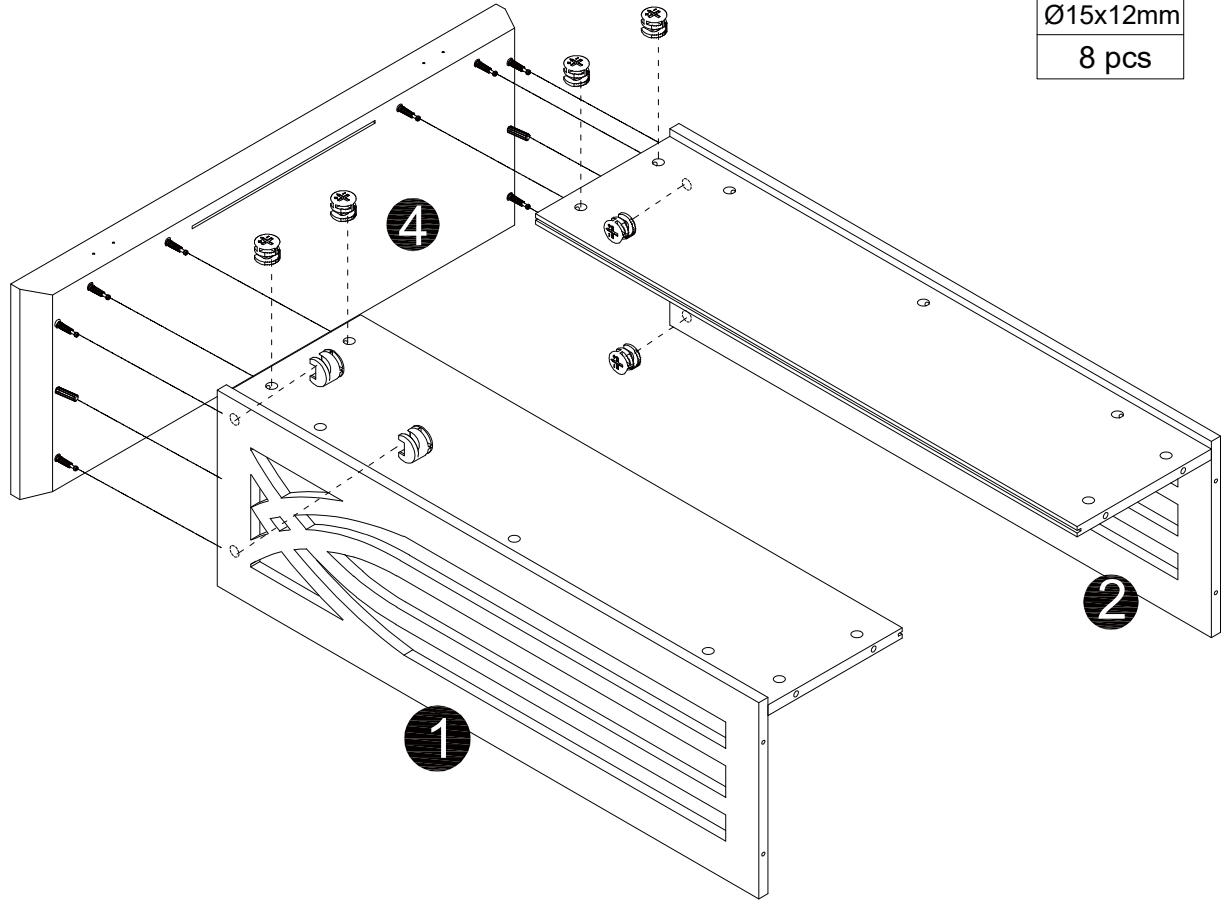
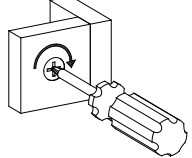

6

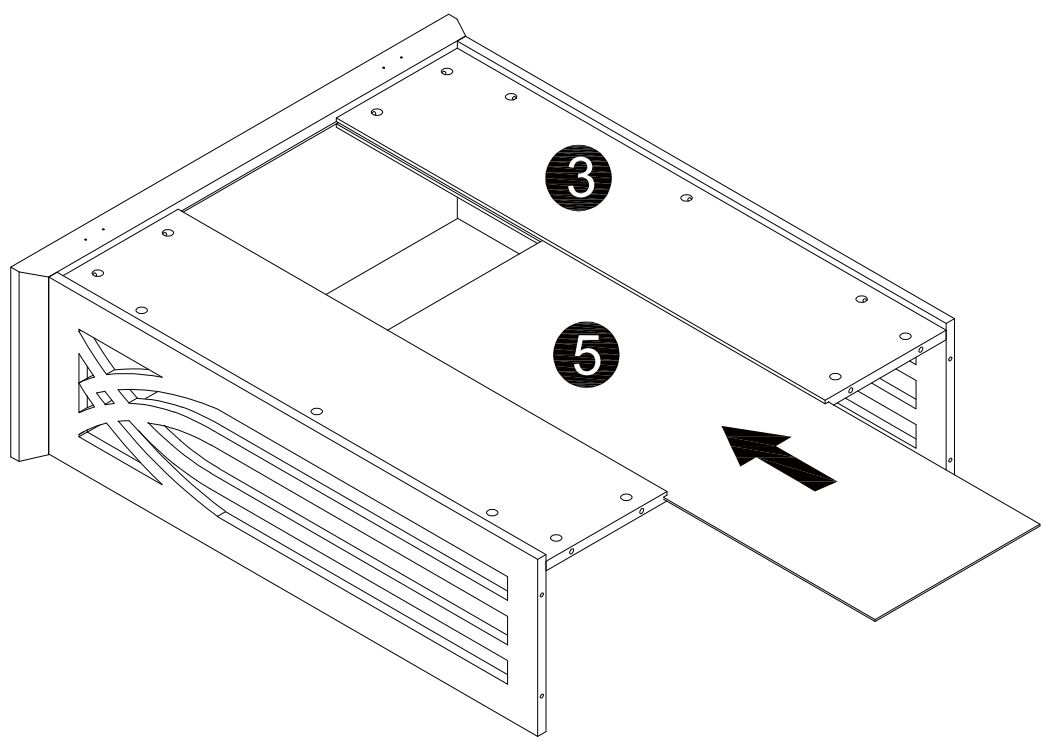

7

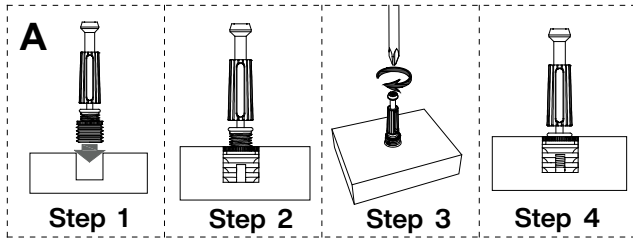

A	K	C
M6x35mm	M6x35mm	Ø8x30mm
4 pcs	8 pcs	2 pcs

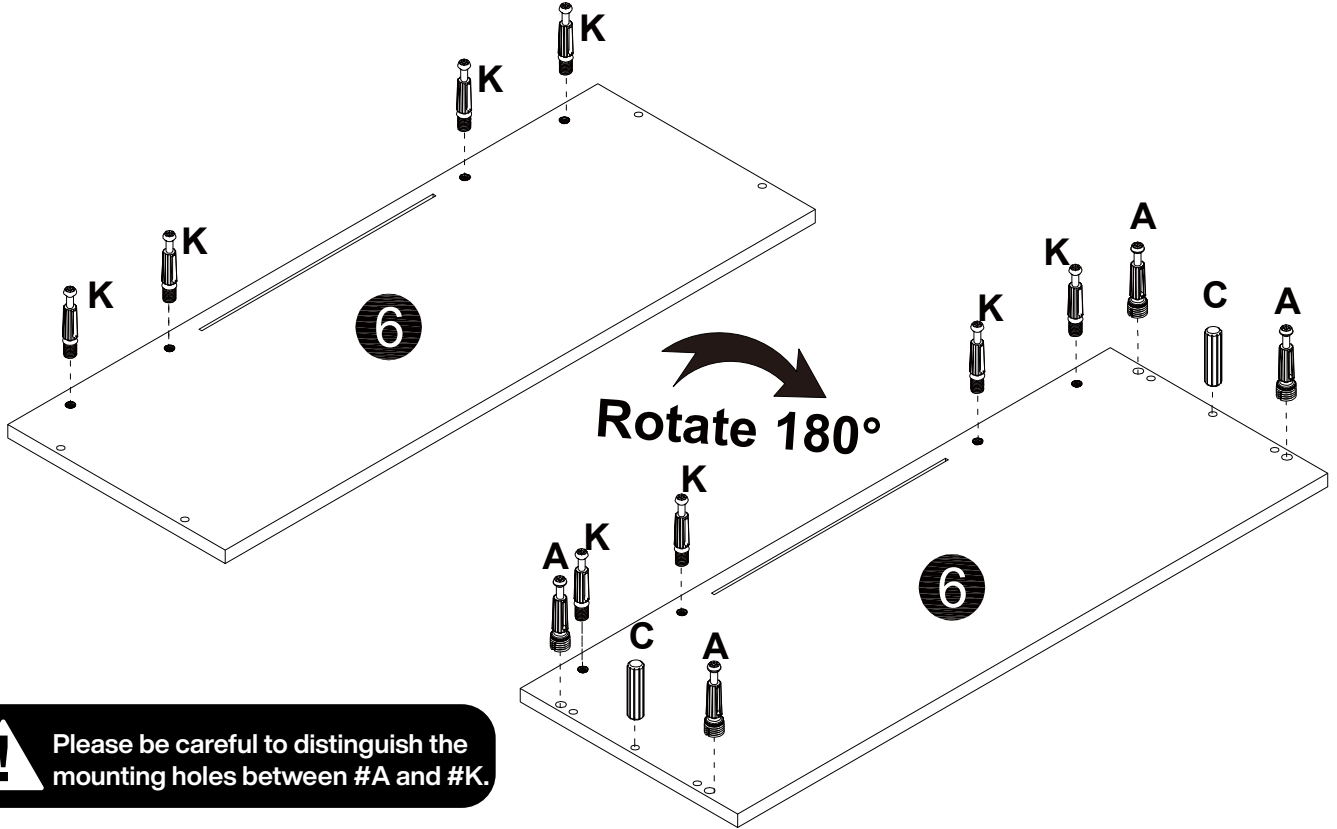

! Please be careful to distinguish the mounting holes between #A and #K.

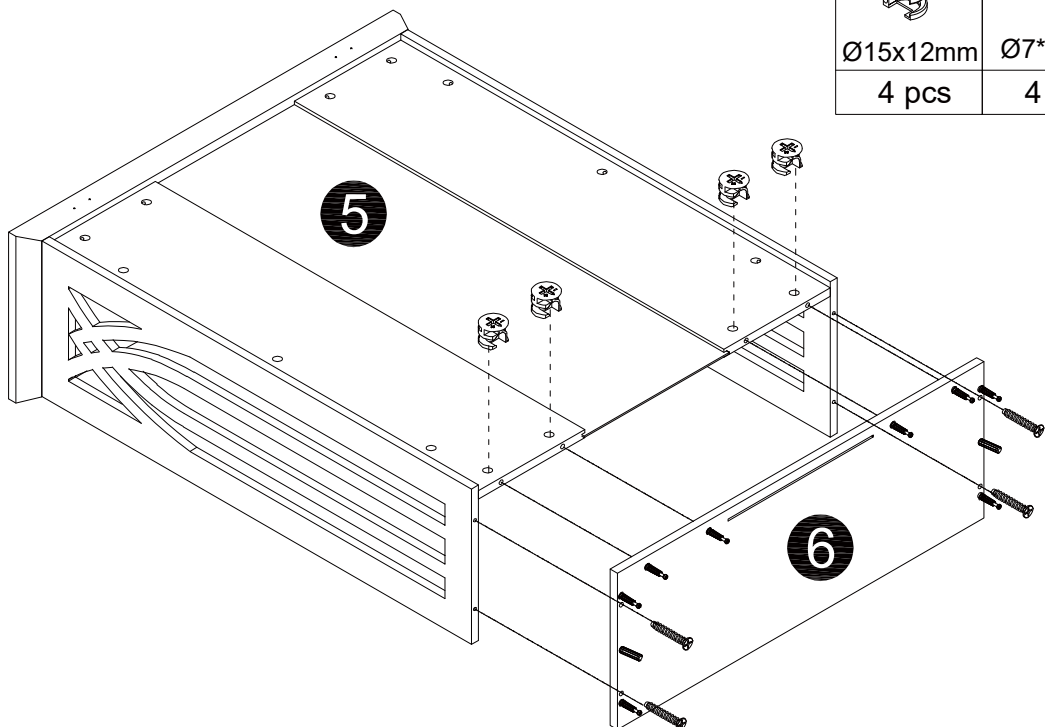
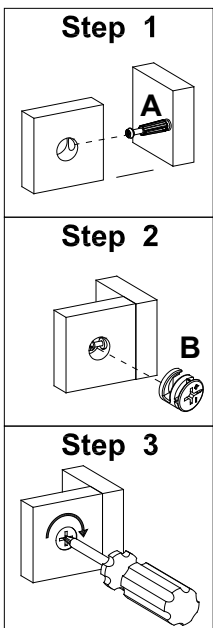

8

B	J
Ø15x12mm	Ø7*38mm
4 pcs	4 pcs

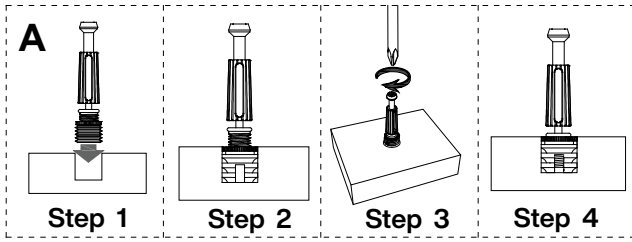

9



A	K
 M6x35mm 6 pcs	

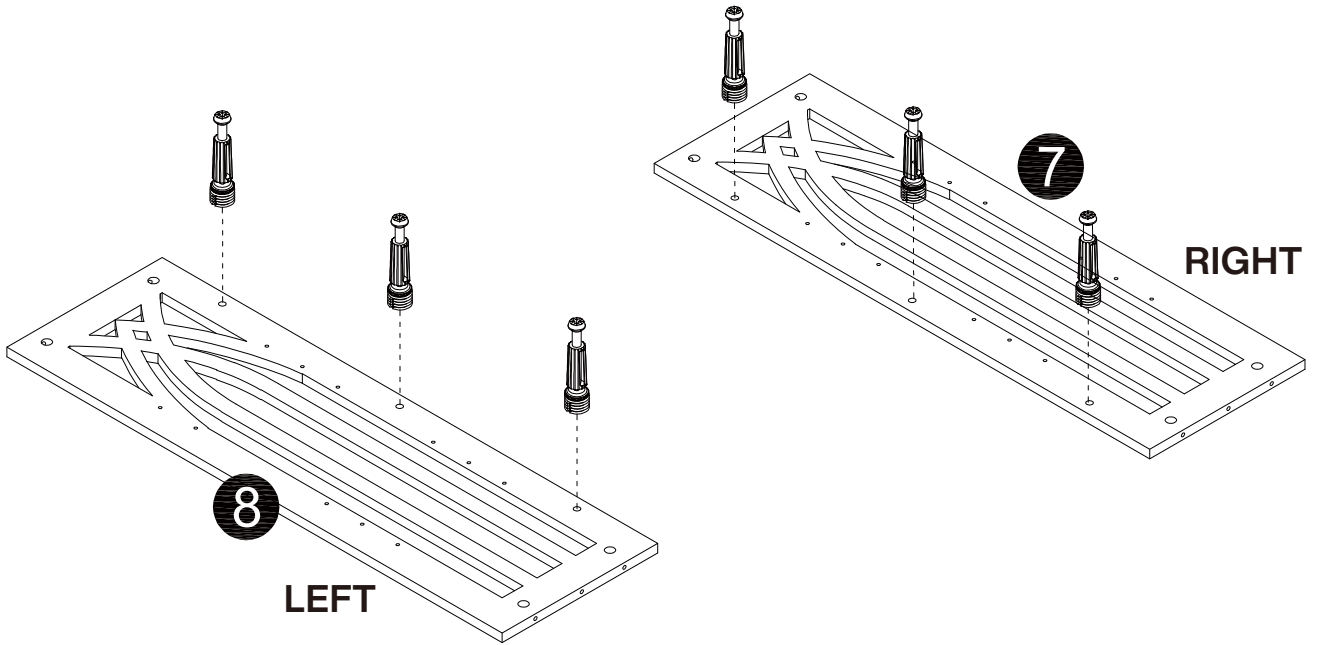

10

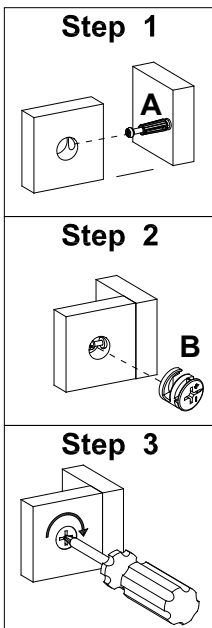

B
 Ø15x12mm 3 pcs

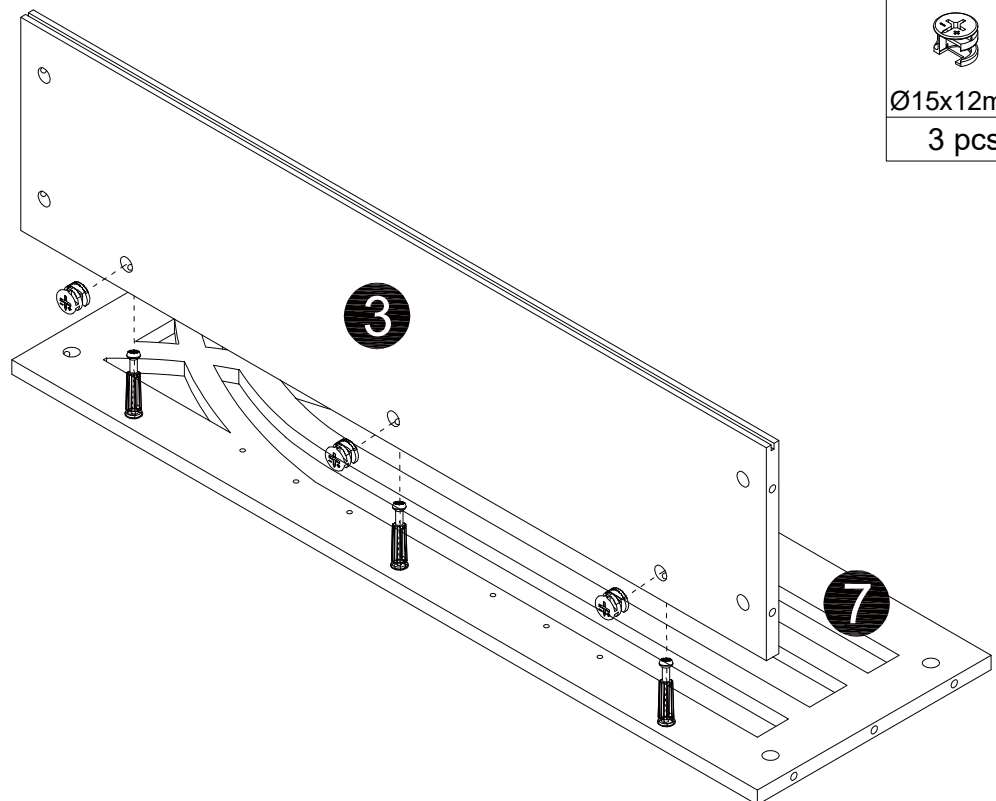

11

B

Ø15x12mm
3 pcs

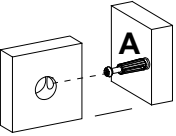
Step 1

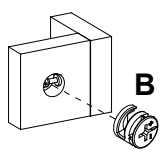

Step 2



Step 3

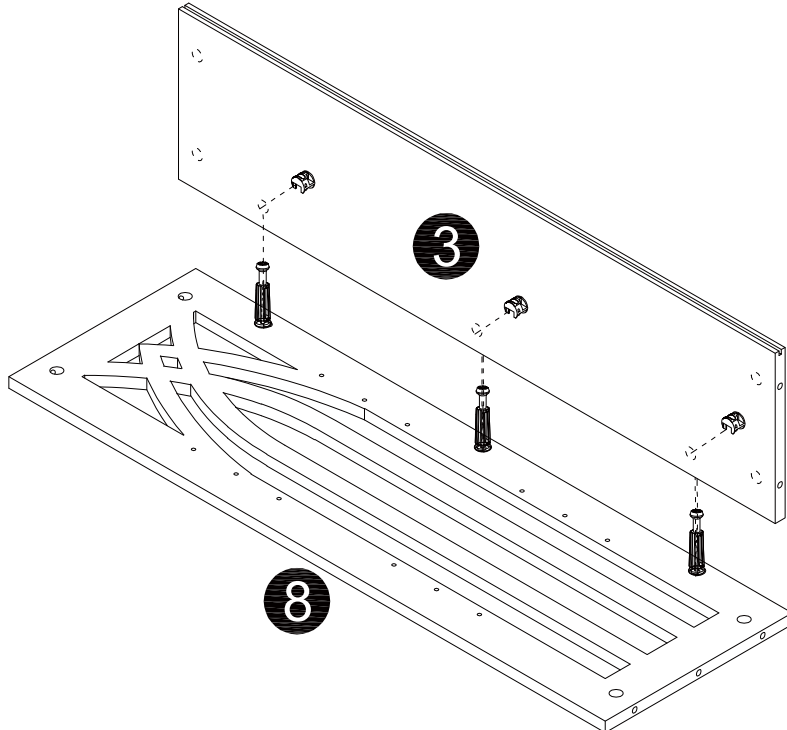
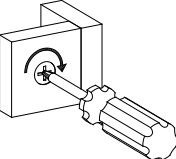

12

B

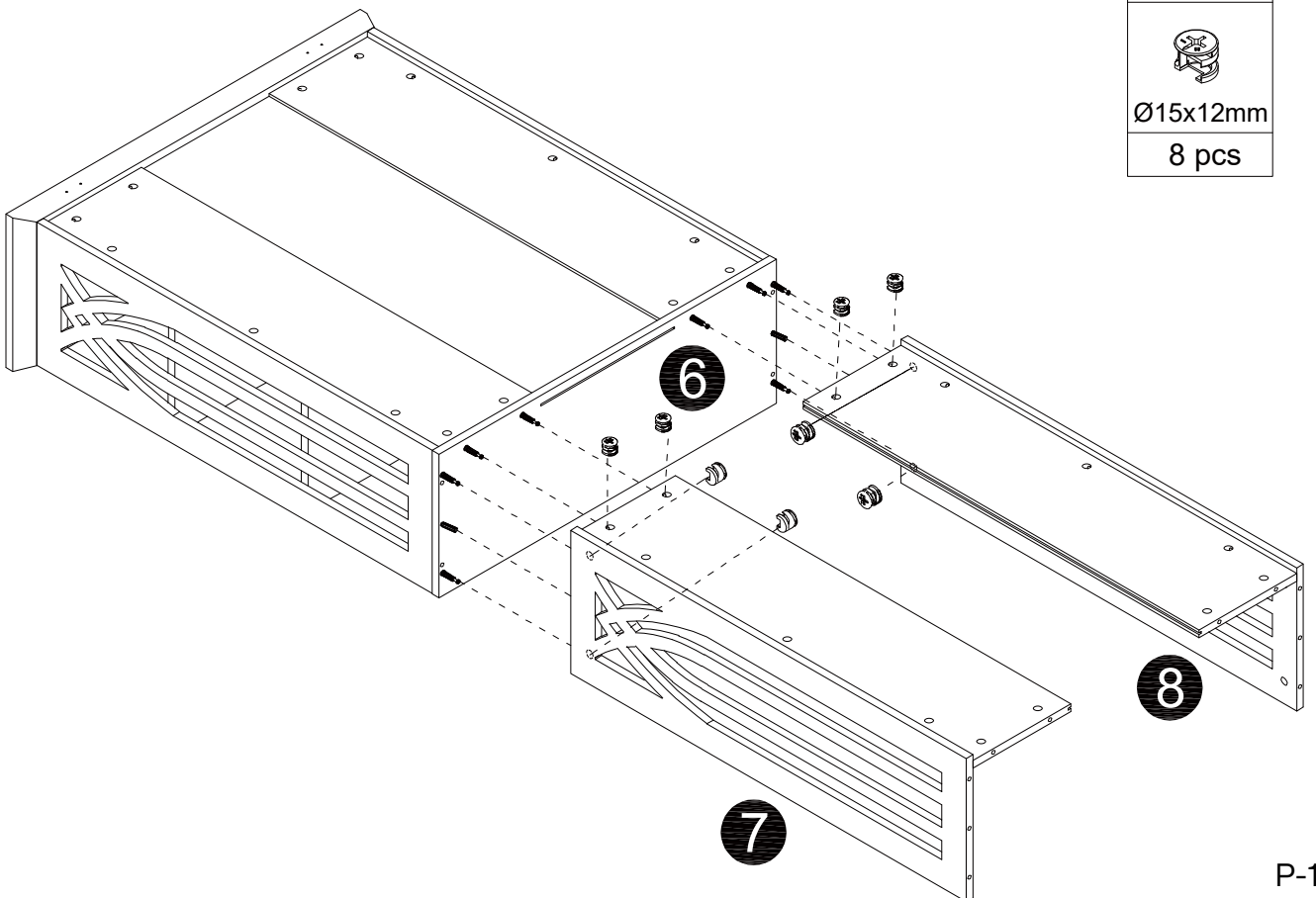
Ø15x12mm
8 pcs



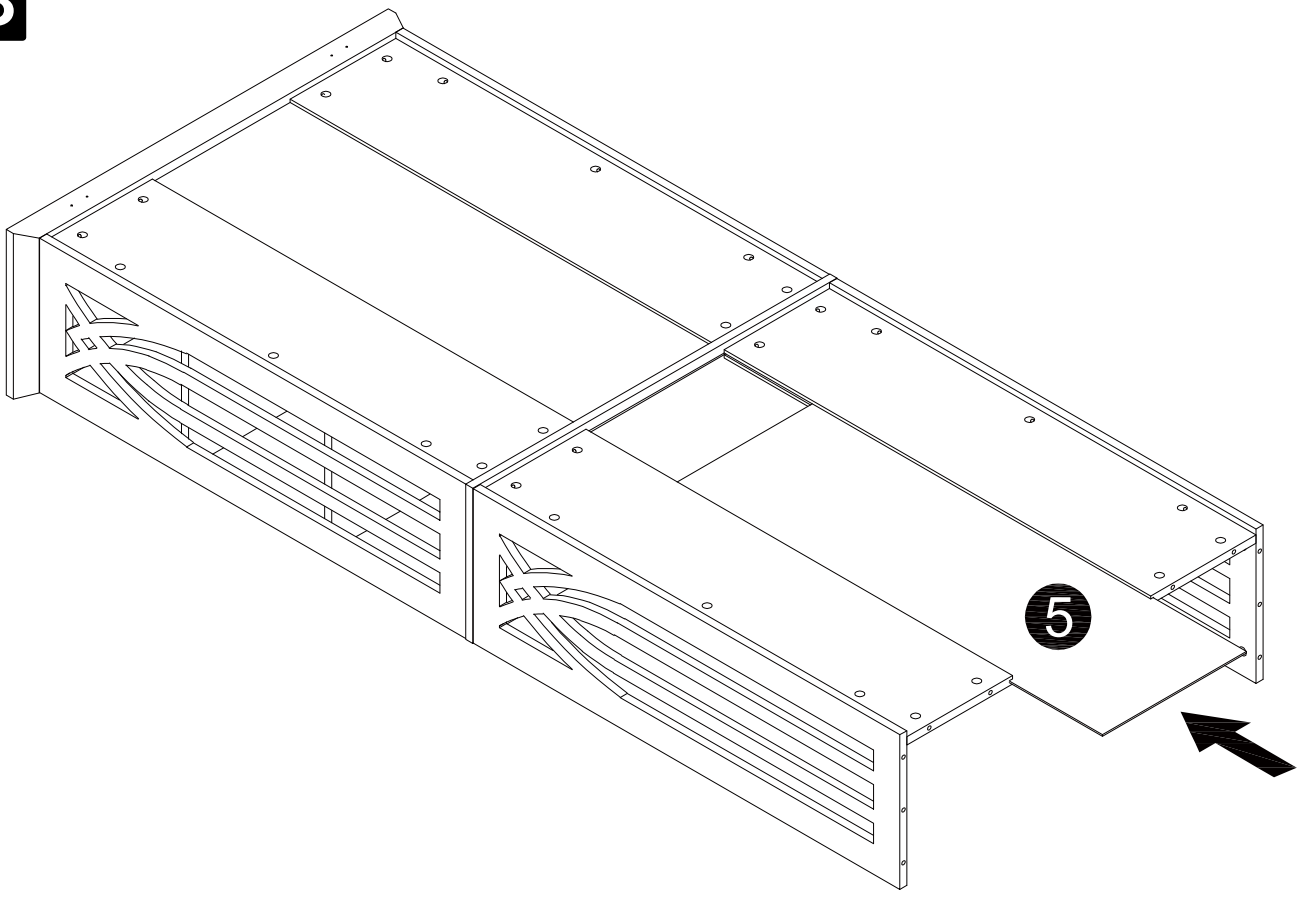

13

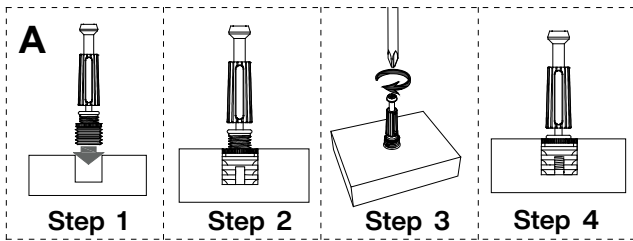

14



C	A	K
		
Ø8x30mm	M6x35mm	
2 pcs	8 pcs	

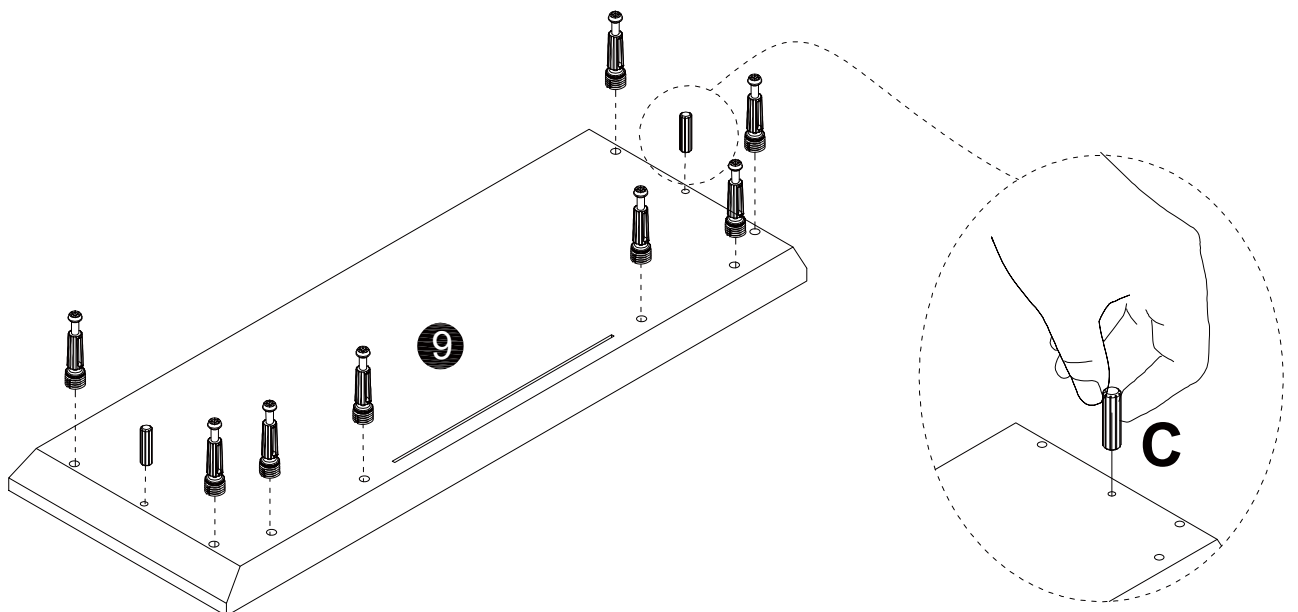

15

B

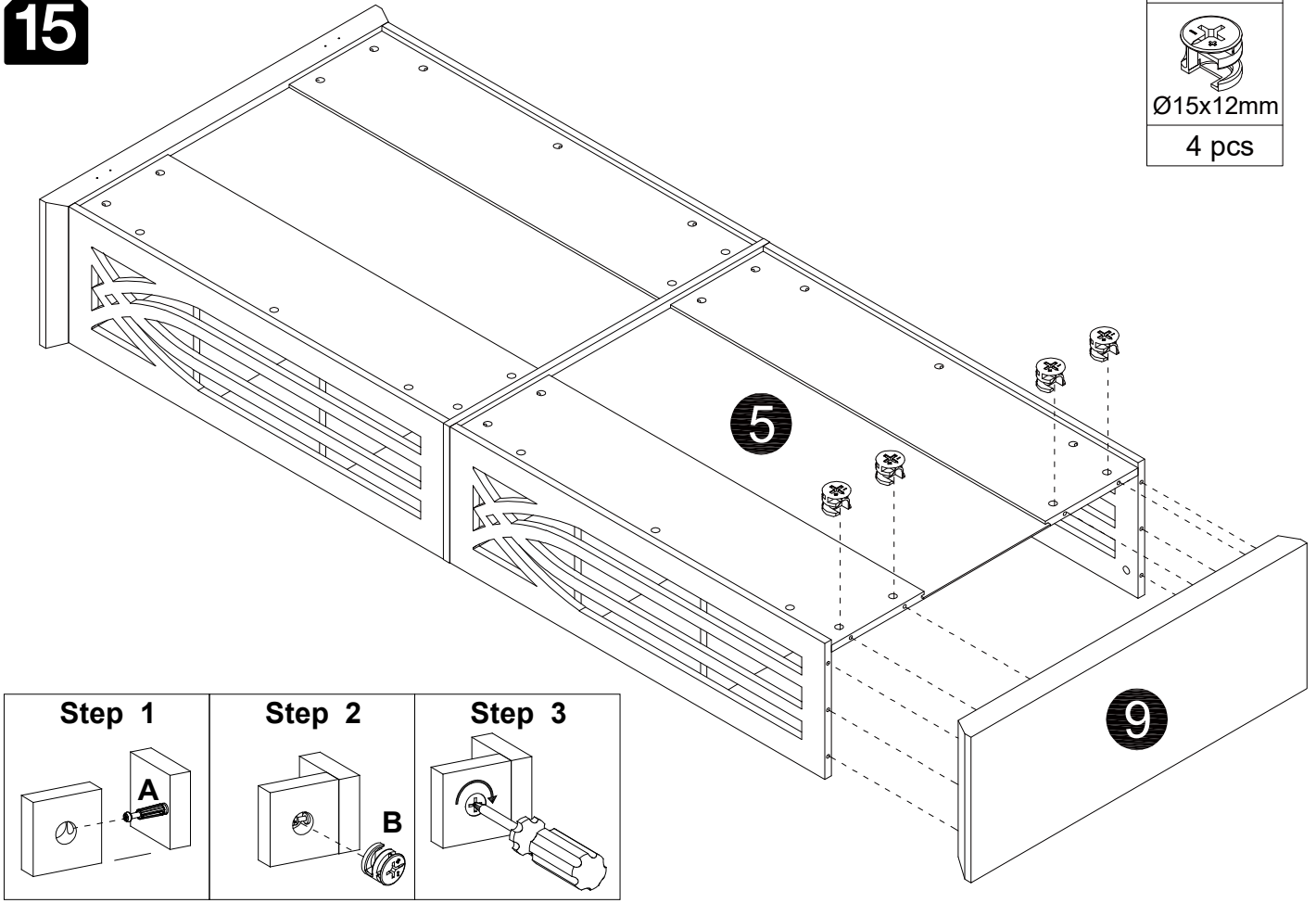
Ø15x12mm
4 pcs

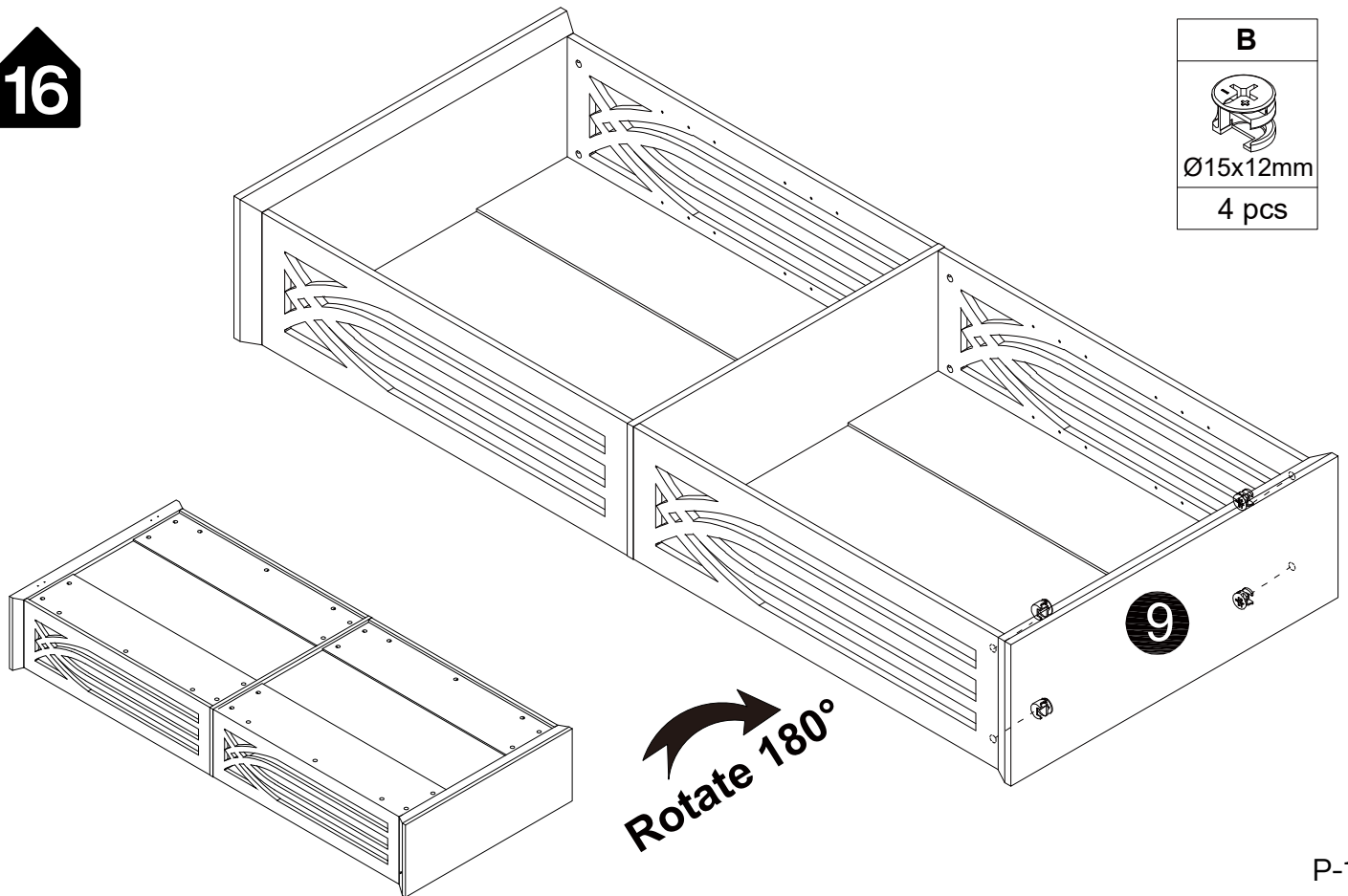

16

B

Ø15x12mm
4 pcs

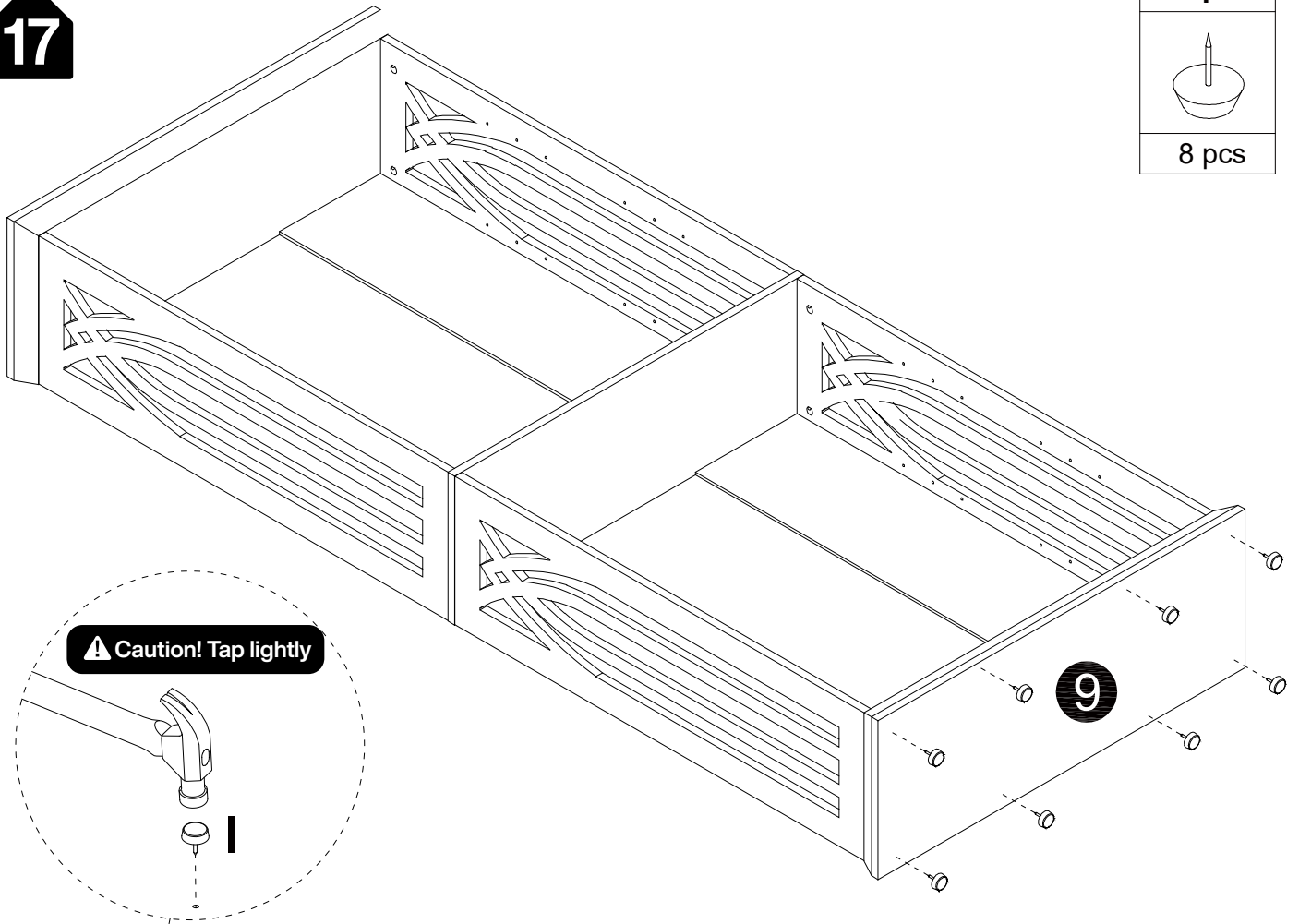

17



⚠ Caution! Tap lightly

I

8 pcs

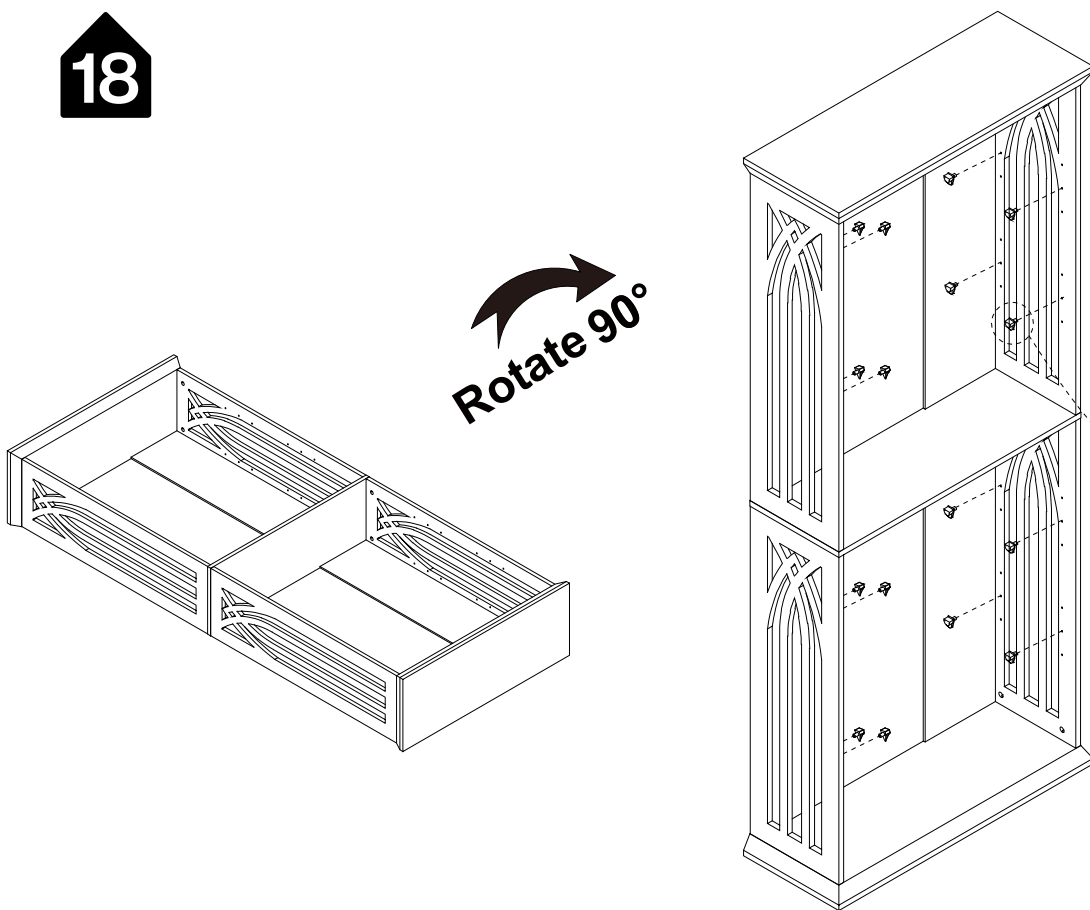
18

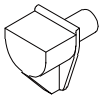

Rotate 90°

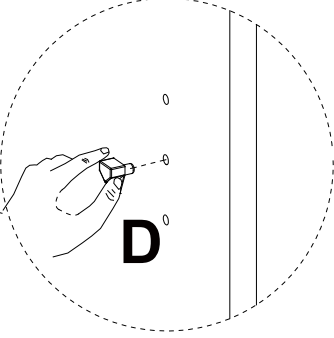
D

16 pcs



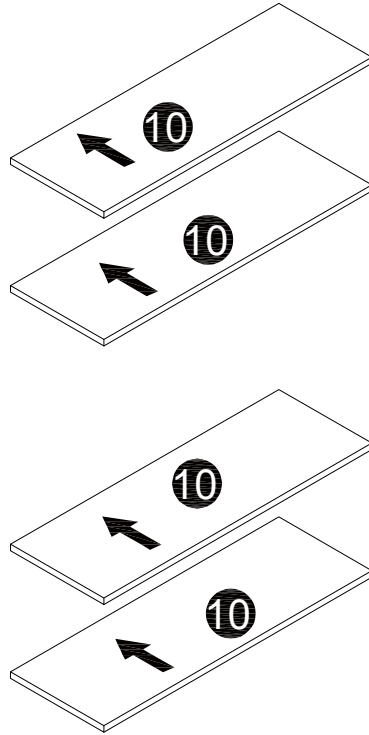
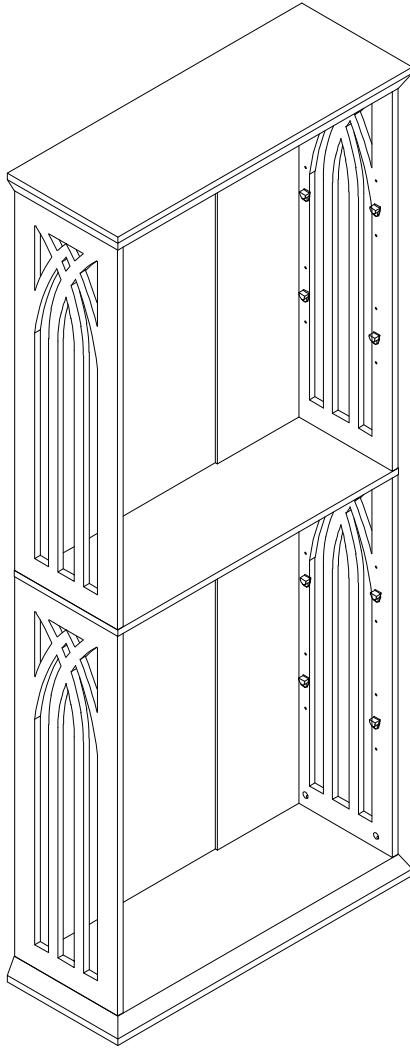

19

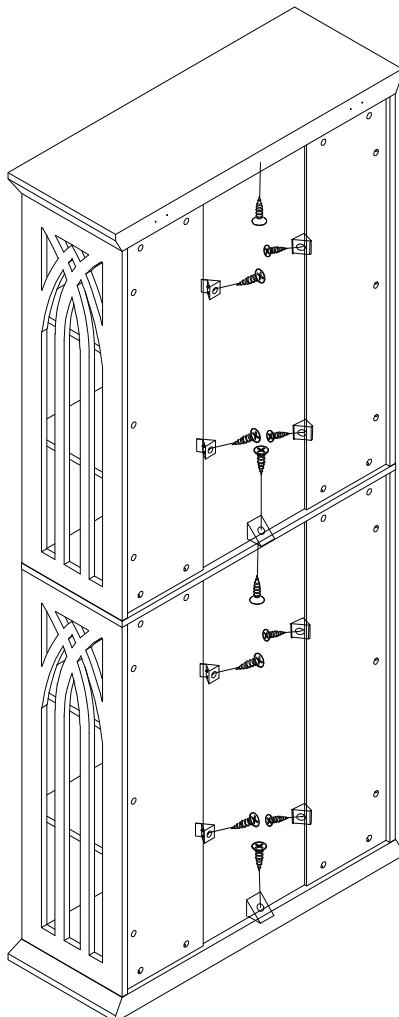

20

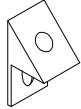

G	H
	
12 pcs	12 pcs

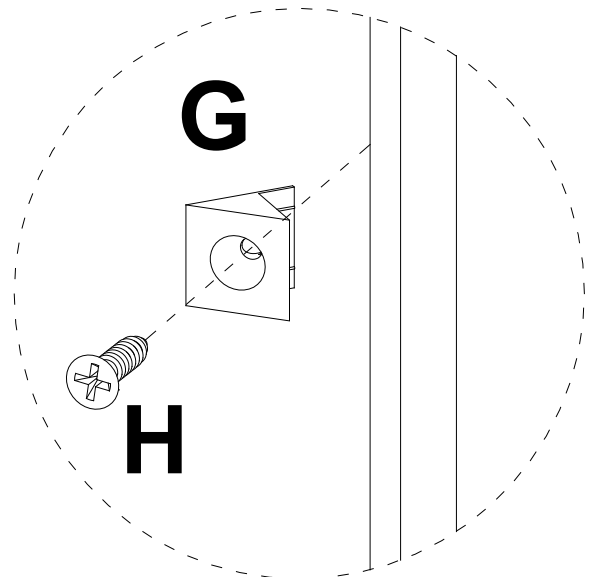

21

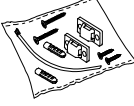
E

2 pcs

Wall

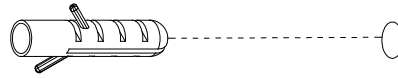
Step1

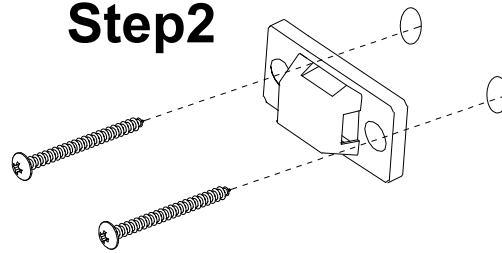

Step2



Step3

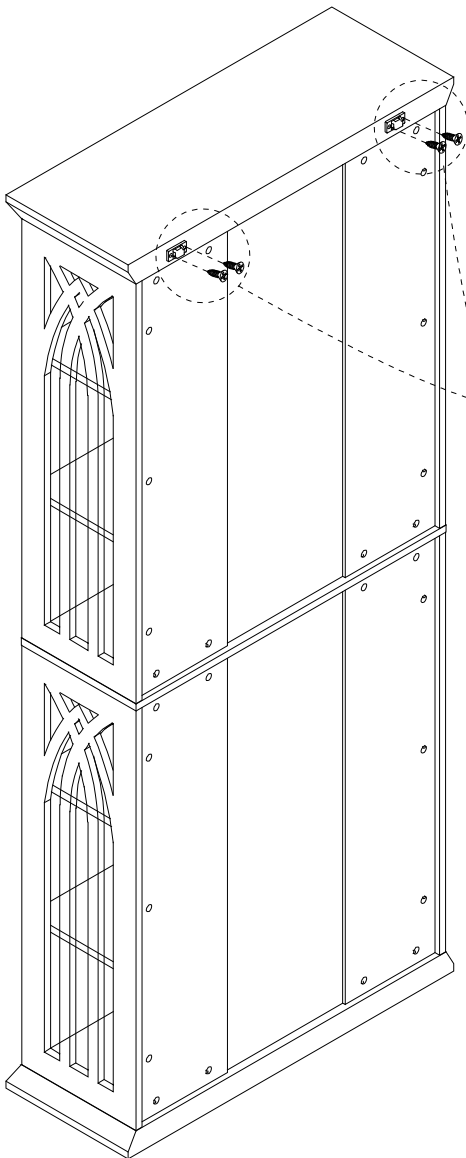
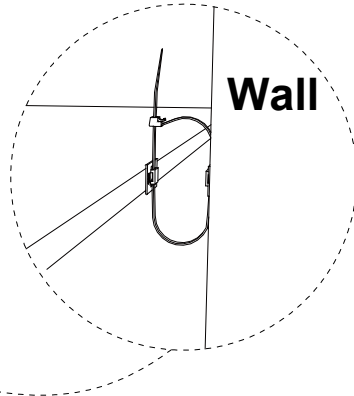

Thank you for your support!

