

Assembly Instructions

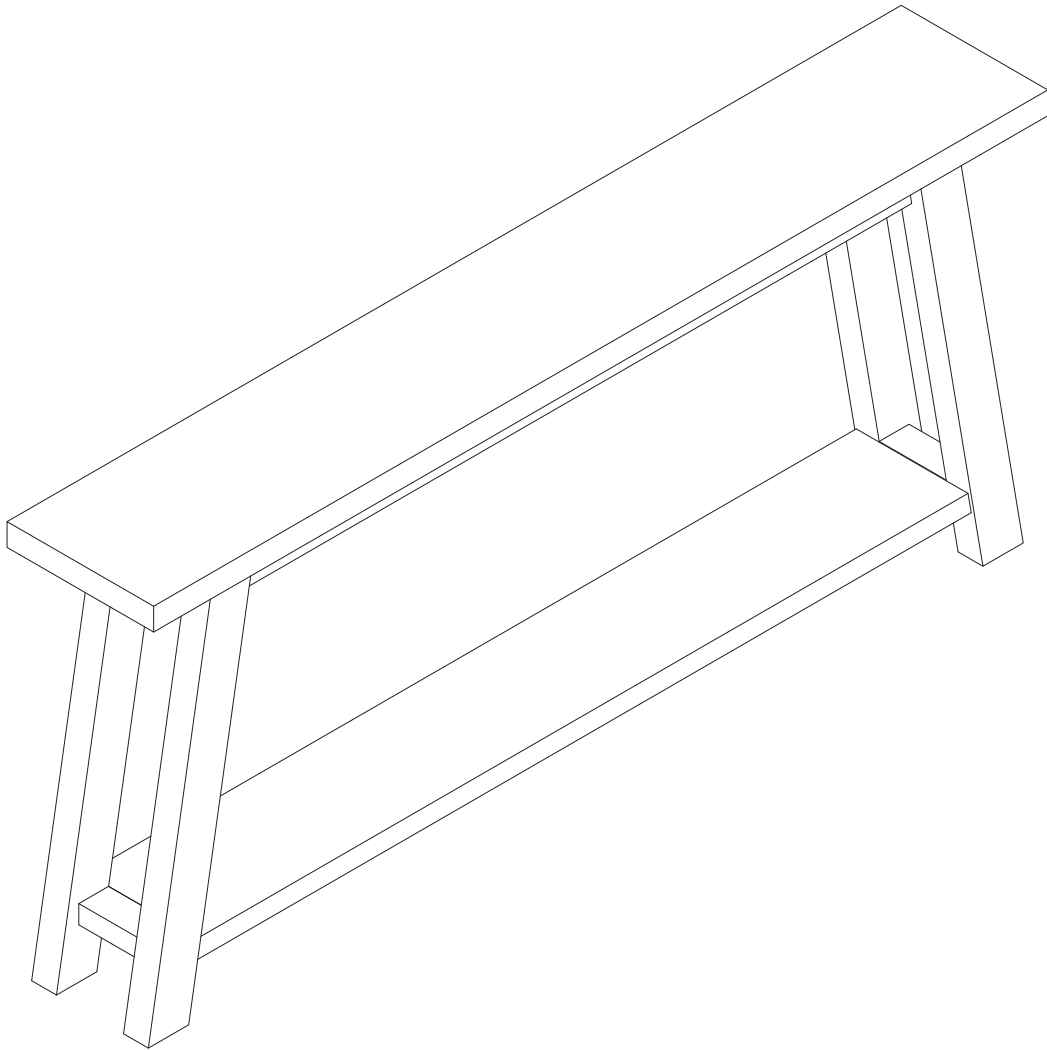

Console Table

Model No.
HOGA-F2367

Contact Us

We're here to help you.

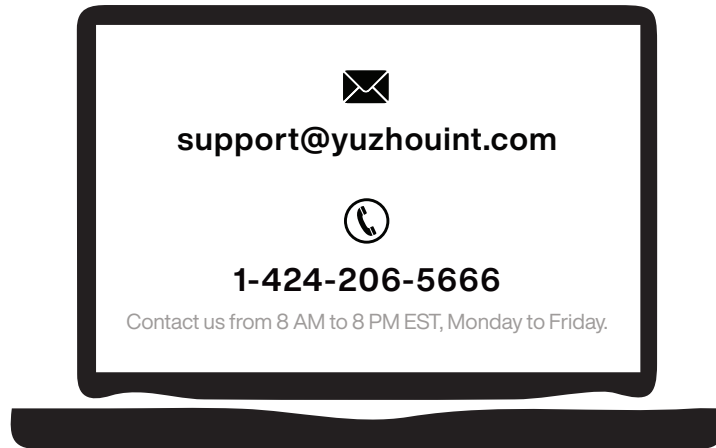

Your satisfaction is our top priority. If you encounter any issues with this product, such as missing or damaged parts, we're here to help. Please retain the original packaging and take photos of the packaging and the product, then contact us as soon as possible.

Warm Tips

1. Carefully read these instructions and keep them for future reference.
2. Check the parts list and confirm everything's there before starting assembly.
3. When assembling, put all parts on a soft, smooth surface like a carpet to avoid scratches.
4. Don't fully tighten screws until all parts are confirmed in place to avoid misalignment.

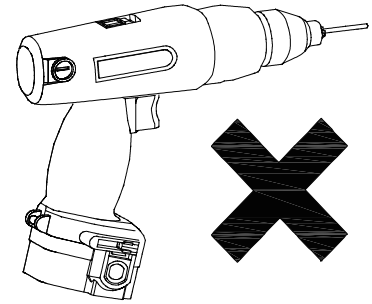
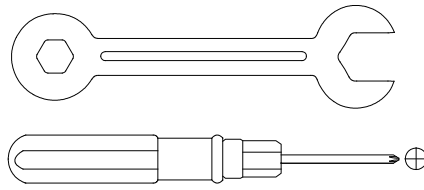
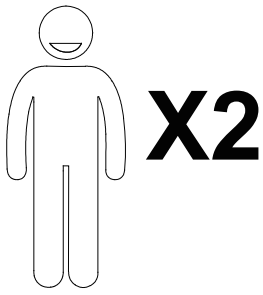

We recommend using hand tools for assembly.

If an electric screwdriver is used, reduce power and torque to avoid damage to the product.

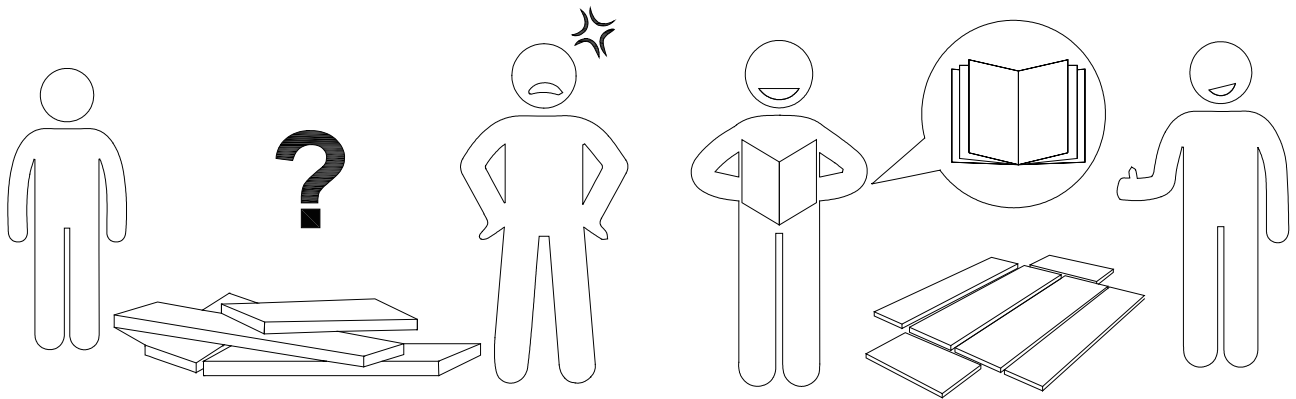

Install the Anti-Tip Straps

Using the anti-tip straps can reduce the risk of tipping over, but can not eliminate it.

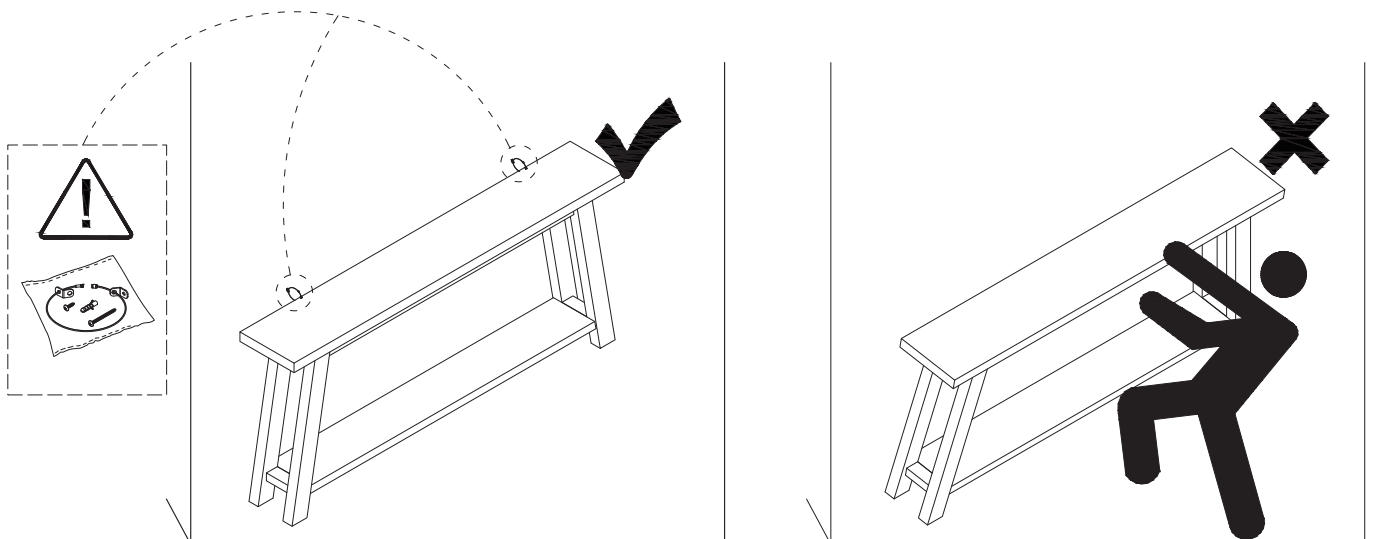

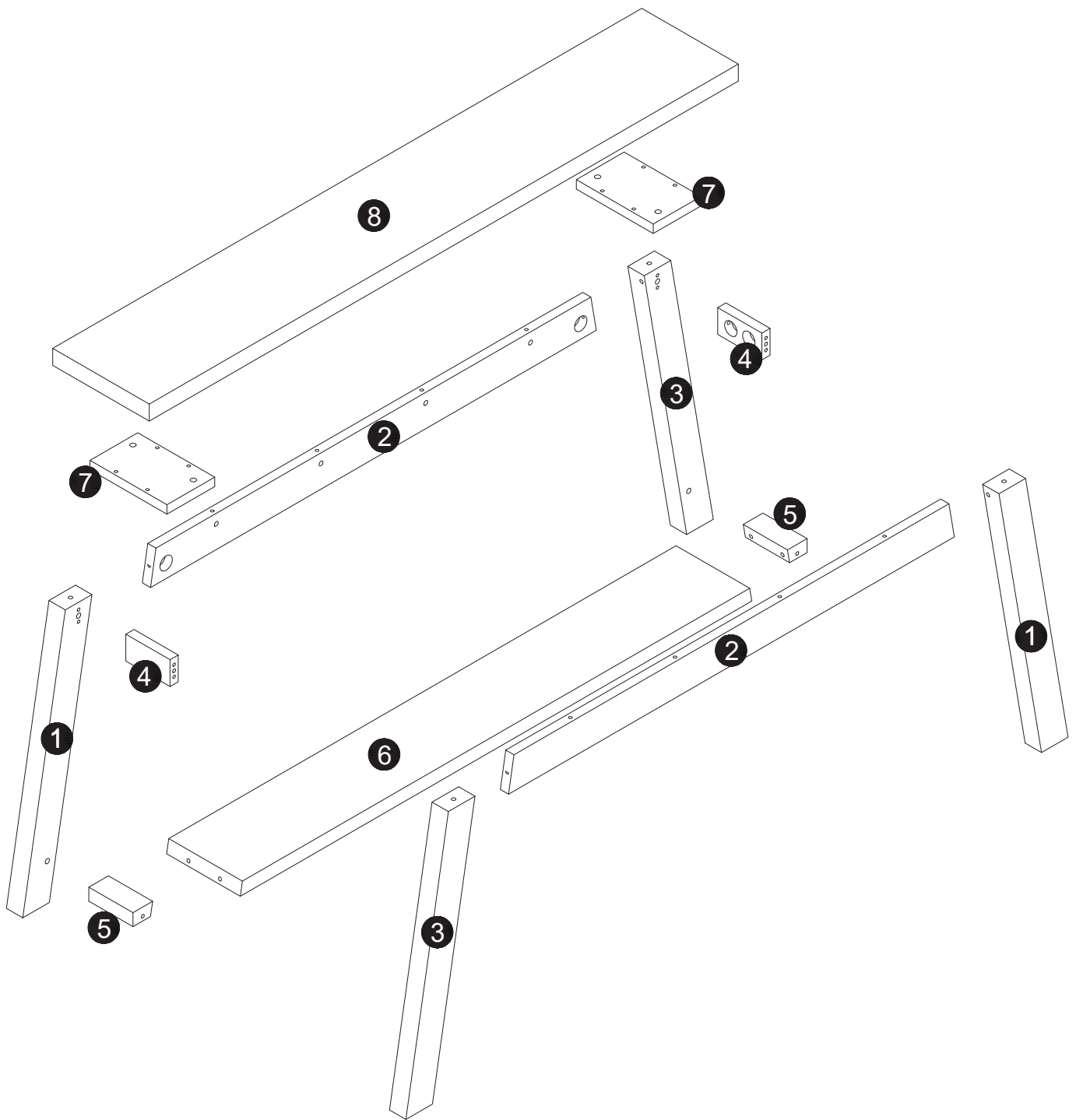





⚠ Caution

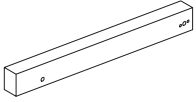
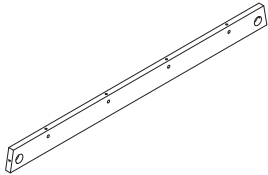
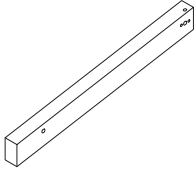
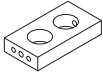
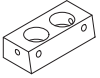
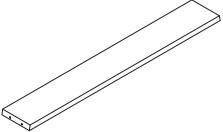
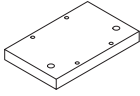
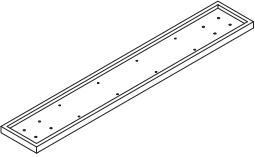



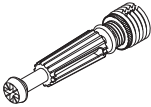

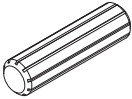
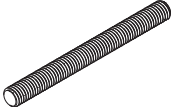
Make sure all parts are included. Most board parts are labeled or stamped on the raw edge. Contact us for a free replacement if you encounter any damaged or missing parts.

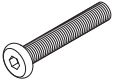
Parts List

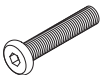
<p>1</p>  <p>2 pcs</p>	<p>2</p>  <p>2 pcs</p>	<p>3</p>  <p>2 pcs</p>	<p>4</p>  <p>2 pcs</p>	<p>5</p>  <p>2 pcs</p>
<p>6</p>  <p>1 pc</p>	<p>7</p>  <p>2 pcs</p>	<p>8</p>  <p>1 pc</p>		

Hardware List

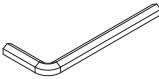
A	B	C	D	E	F	G
 <p>M6x35mm</p>	 <p>Ø12x10mm</p>	 <p>Ø8x30mm</p>	 <p>Ø8x60mm</p>	 <p>M8</p>	 <p>M8</p>	 <p>M8x55mm</p>
8+1 pcs	8+1 pcs	8+1 pcs	12+1 pcs	12+1 pcs	12+1 pcs	4+1 pcs

H	I	J	K	L	M	N
 <p>M8x40mm</p>	 <p>M8</p>			 <p>M5</p>	 <p>Wrench M8</p>	 <p>Screwdriver</p>
12+1 pcs	16+1 pcs	4+1 pcs	2 pcs	1 pc	1 pc	1 pc

Installation of Cams and Pins

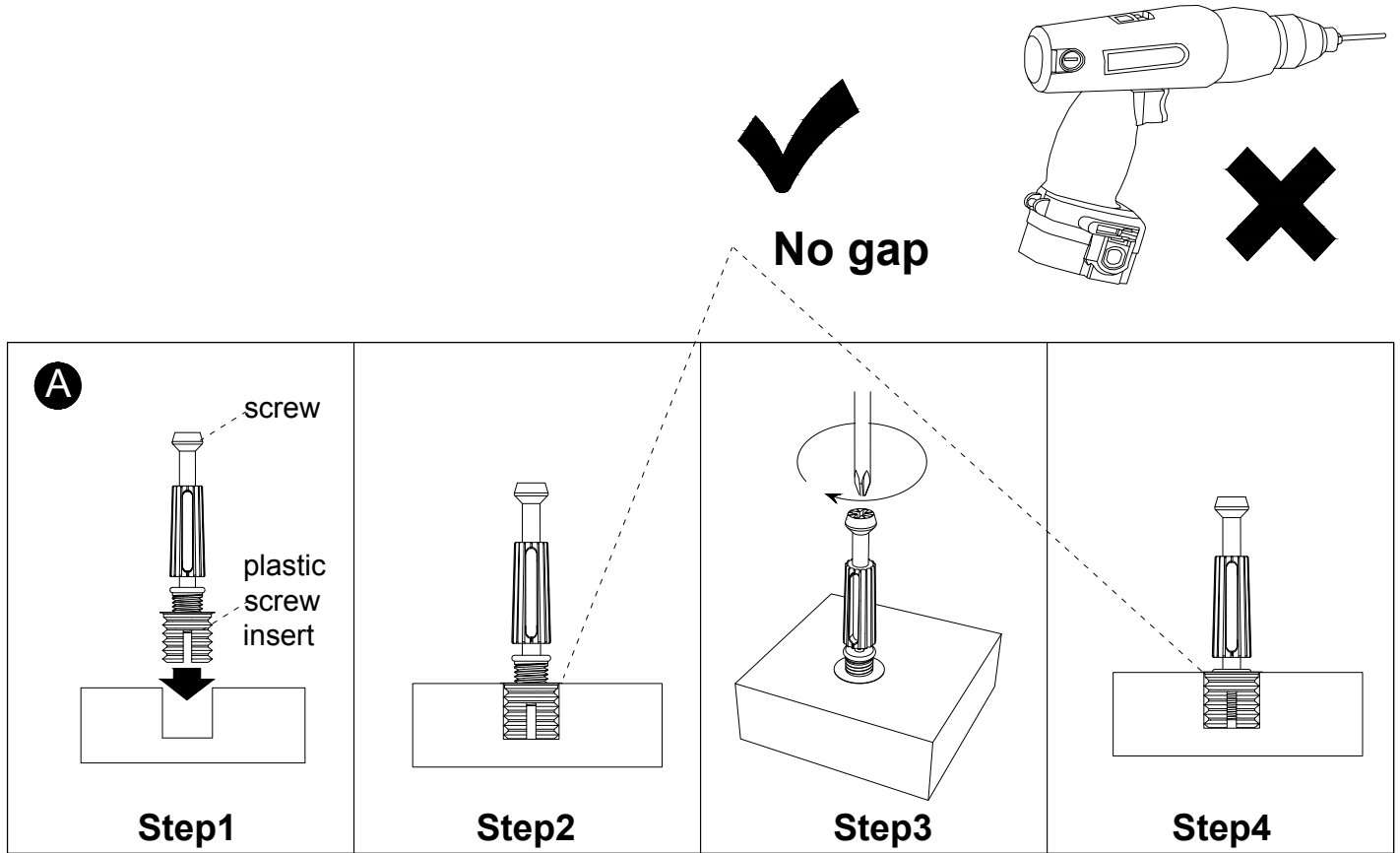

Step 1-2: Align the plastic part with the mounting hole and press it in. If you can't press it in, loosen the screw counter clockwise or completely remove the screw from the plastic part and try again.
Step 3-4: After pressing the plastic part into place, use a screwdriver to tighten the screw clockwise.

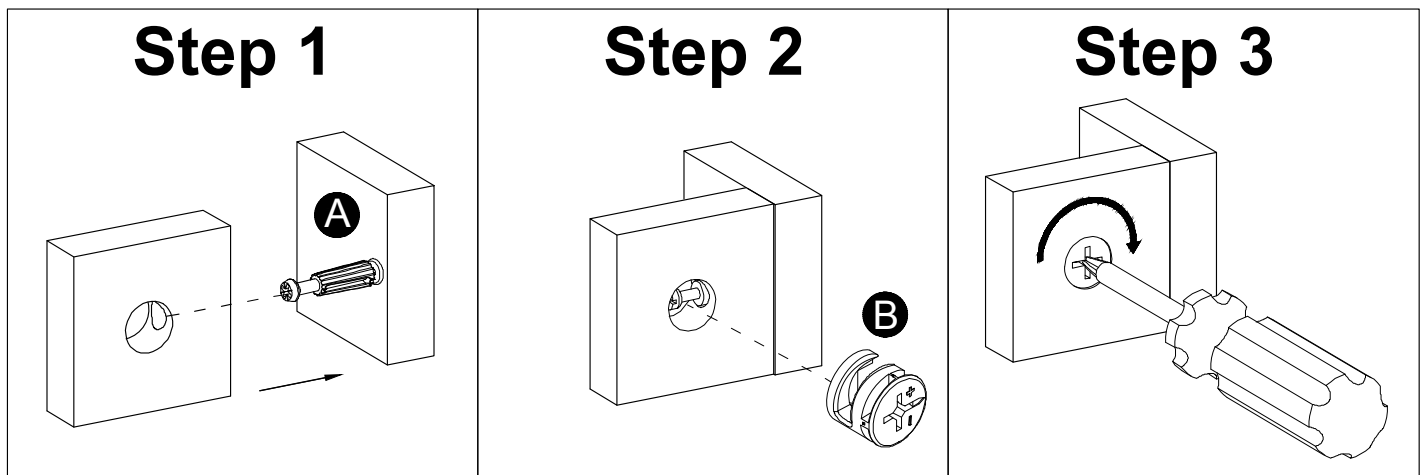

Screw the pin into the hole. Set the cams correctly by aligning the head of the cams with the lock pins. Lock the cam by turning the cam head with a screwdriver until it is tightened. Please do not use an electric screwdriver to assemble the unit.



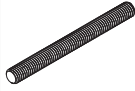

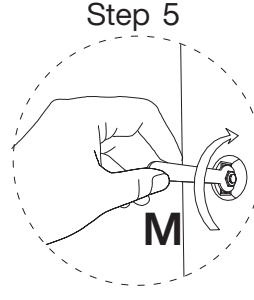
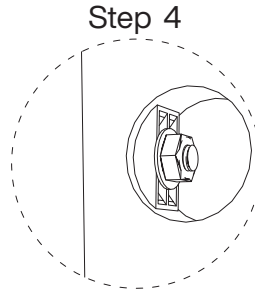
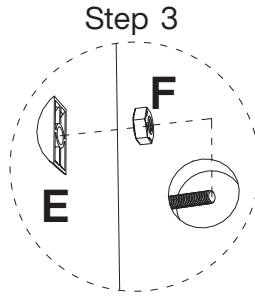
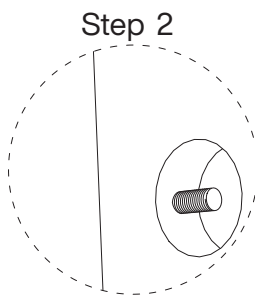
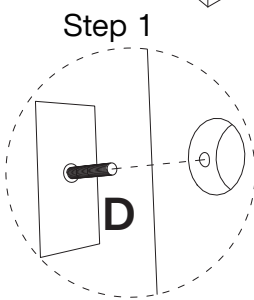
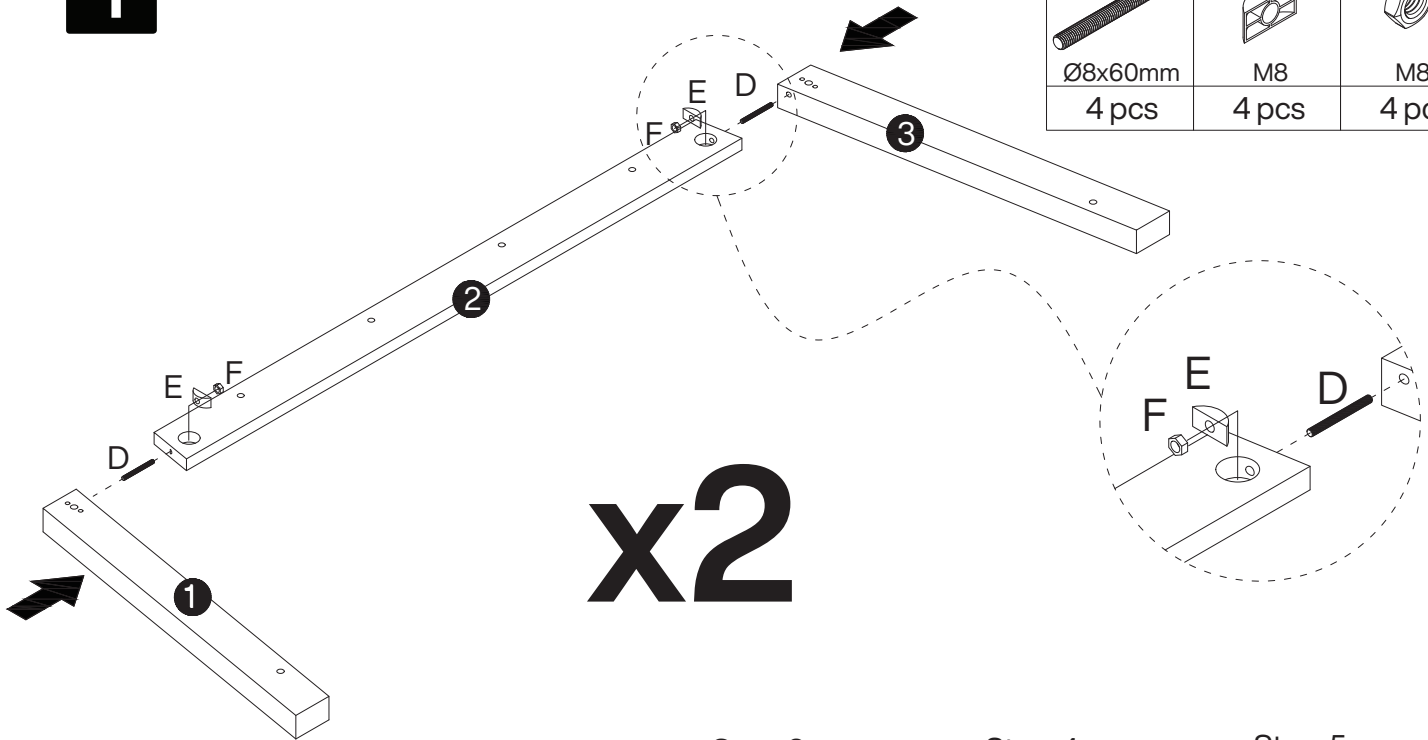

1

D	E	F
		
Ø8x60mm	M8	M8
4 pcs	4 pcs	4 pcs

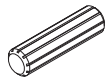



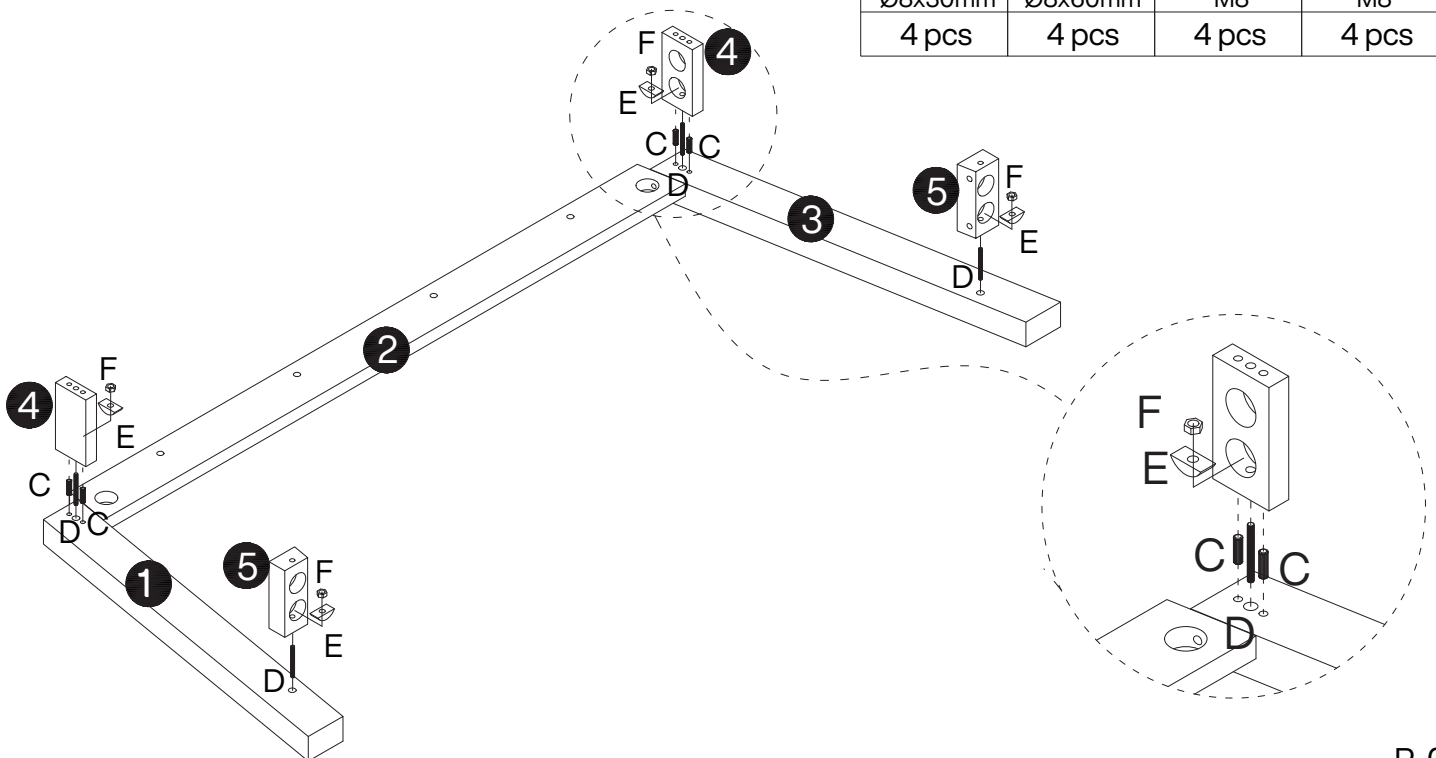

2

C	D	E	F
			
Ø8x30mm	Ø8x60mm	M8	M8
4 pcs	4 pcs	4 pcs	4 pcs



3

C	D	E	F
			
Ø8x30mm	Ø8x60mm	M8	M8
4 pcs	4 pcs	4 pcs	4 pcs

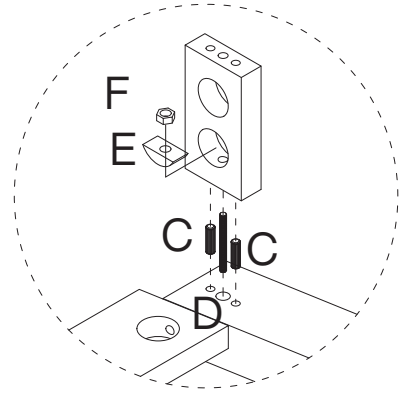
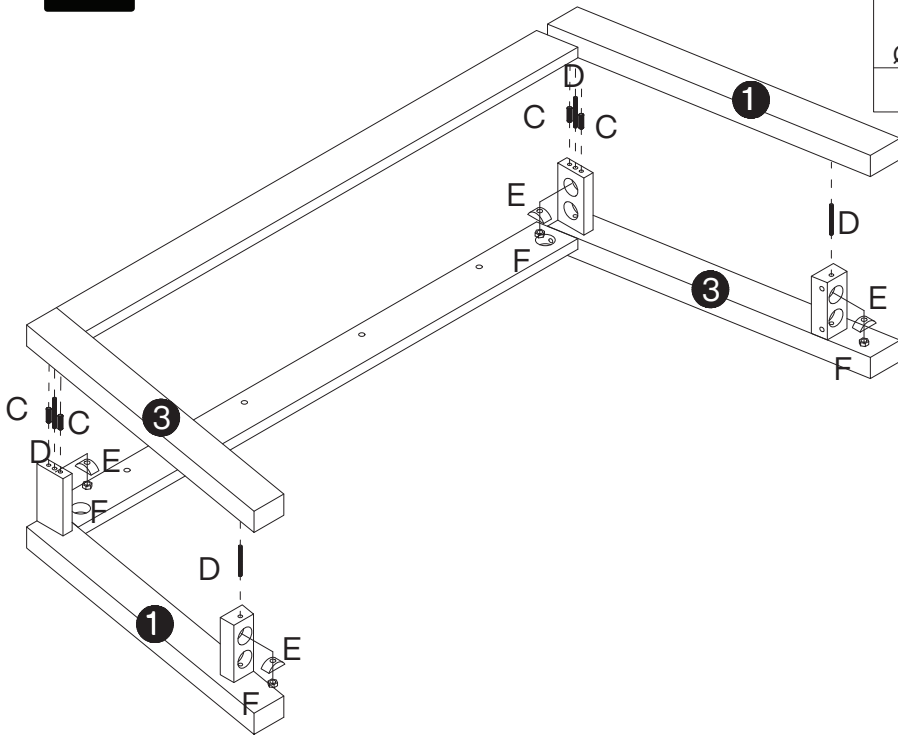

Step 1

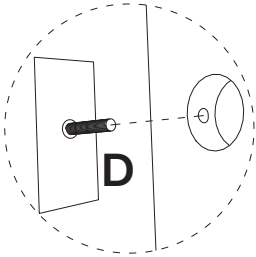

Step 2

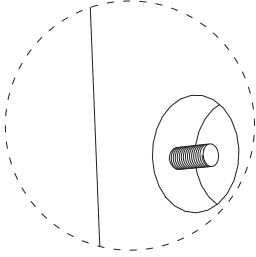

Step 3

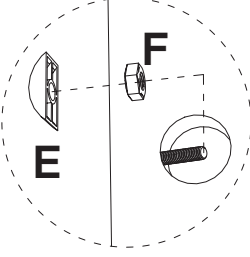

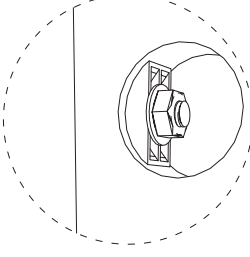

Step 4

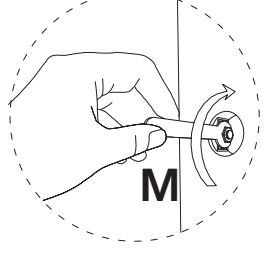

Step 5



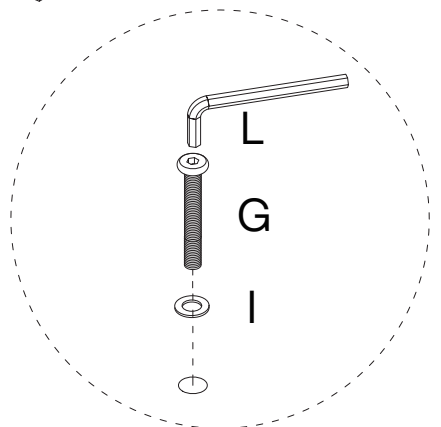
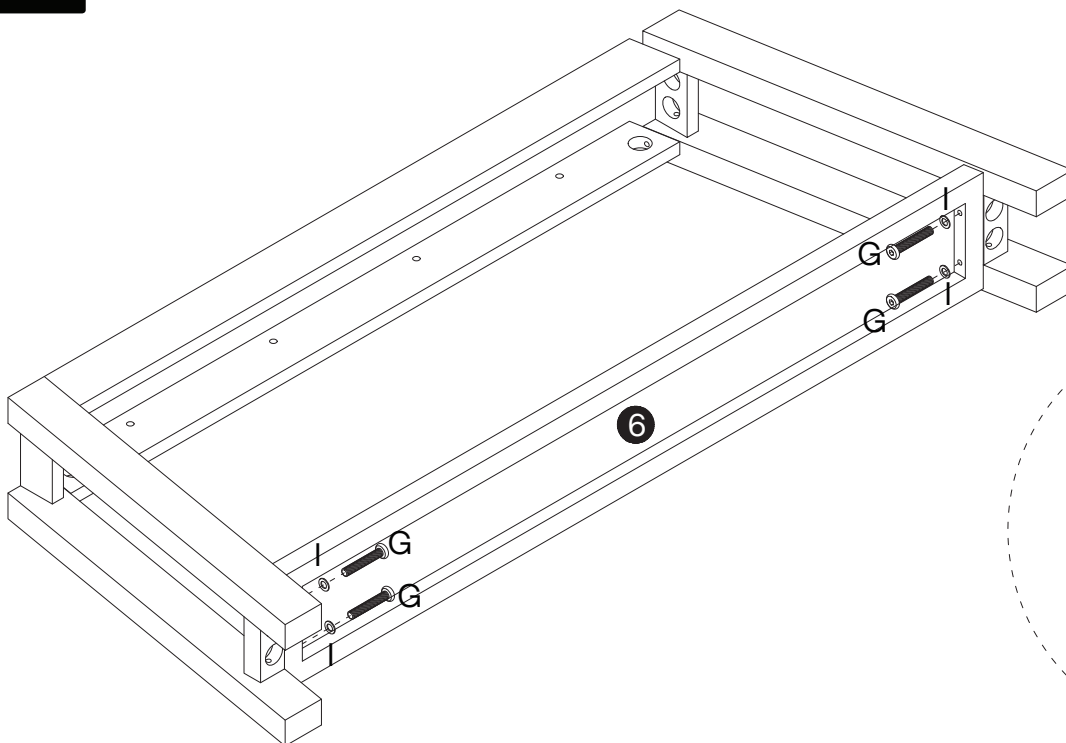

4

G	I
	
M8x55mm	M8
4 pcs	4 pcs

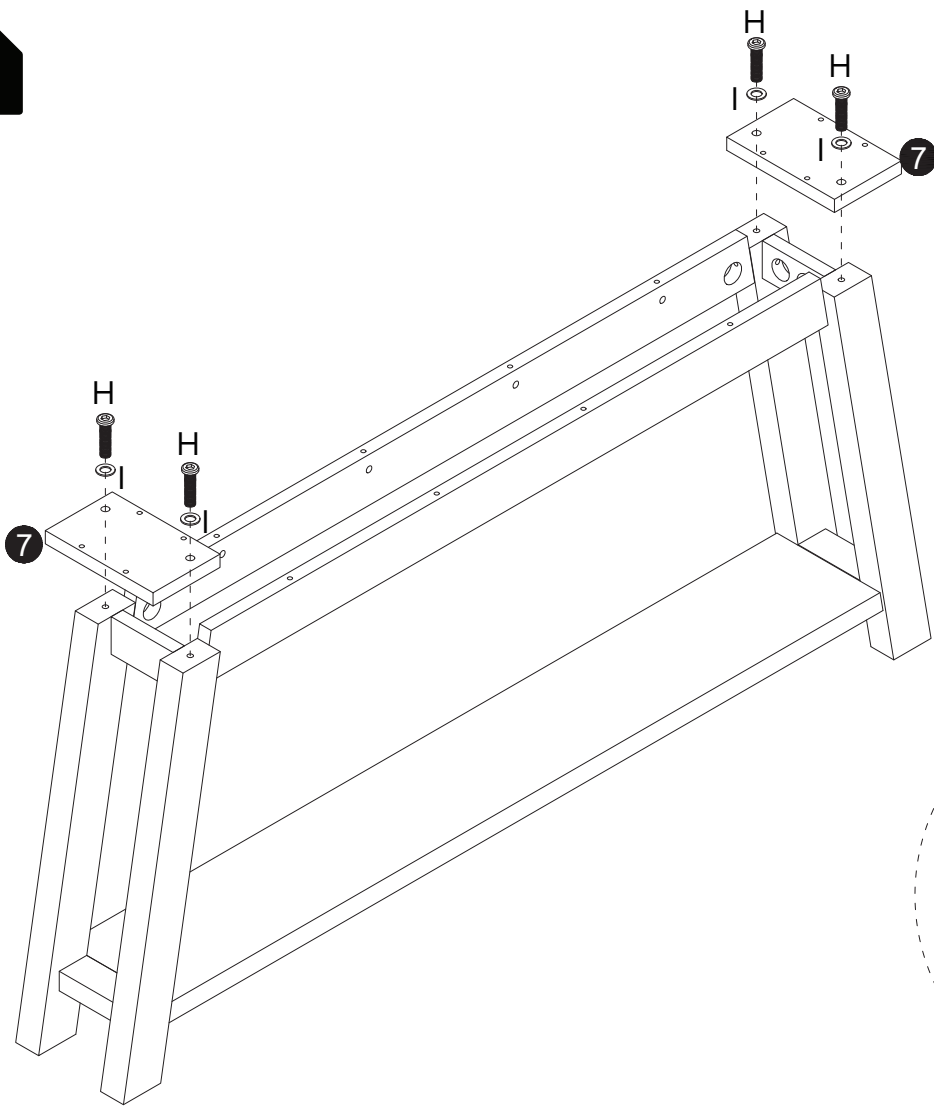

5



H	I
	
M8x40mm	M8
4 pcs	4 pcs

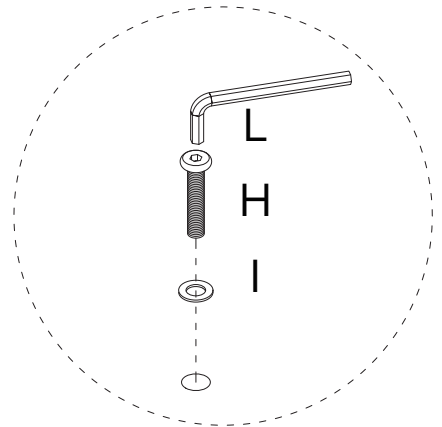

6

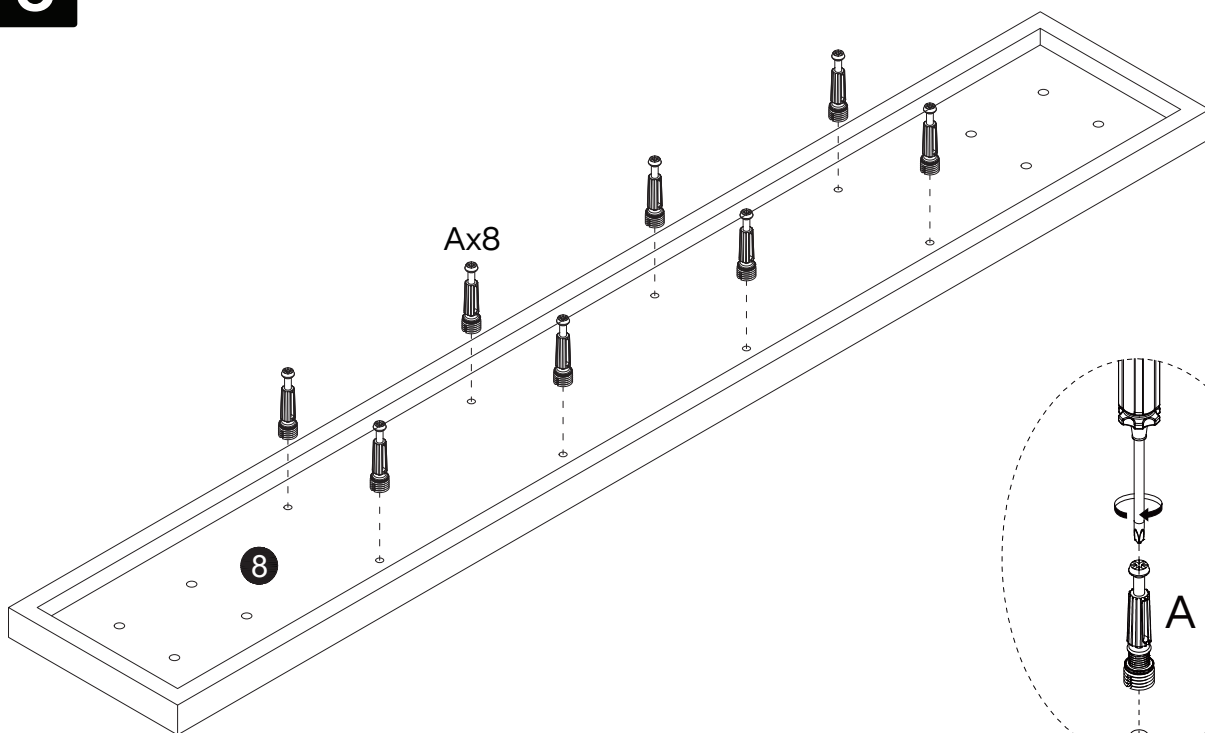

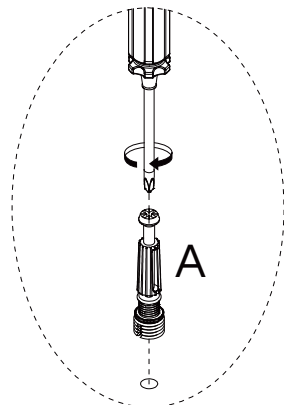

A

M6x35mm
8 pcs

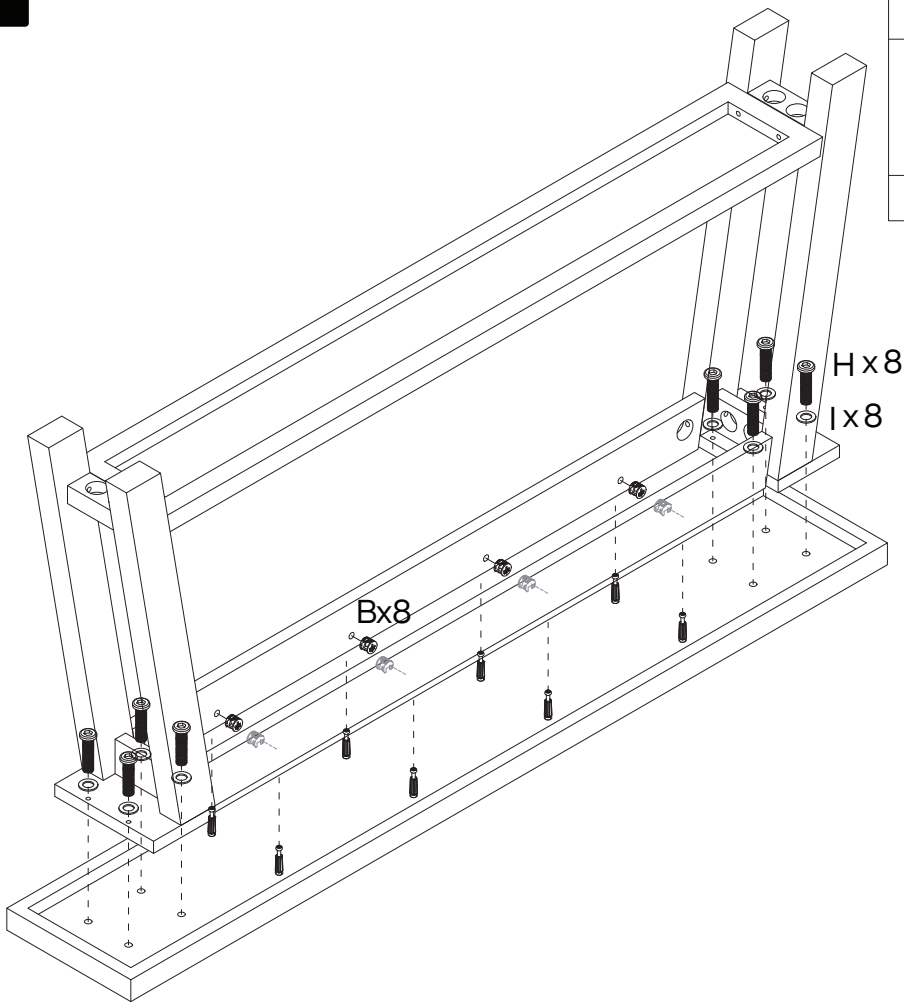

7

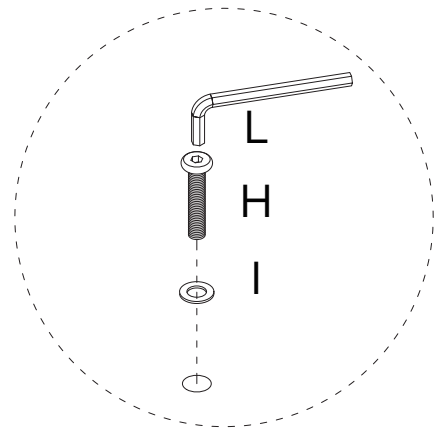

H	I	B
		
M8x40mm	M8	Ø12x10mm
8 pcs	8 pcs	8 pcs



8

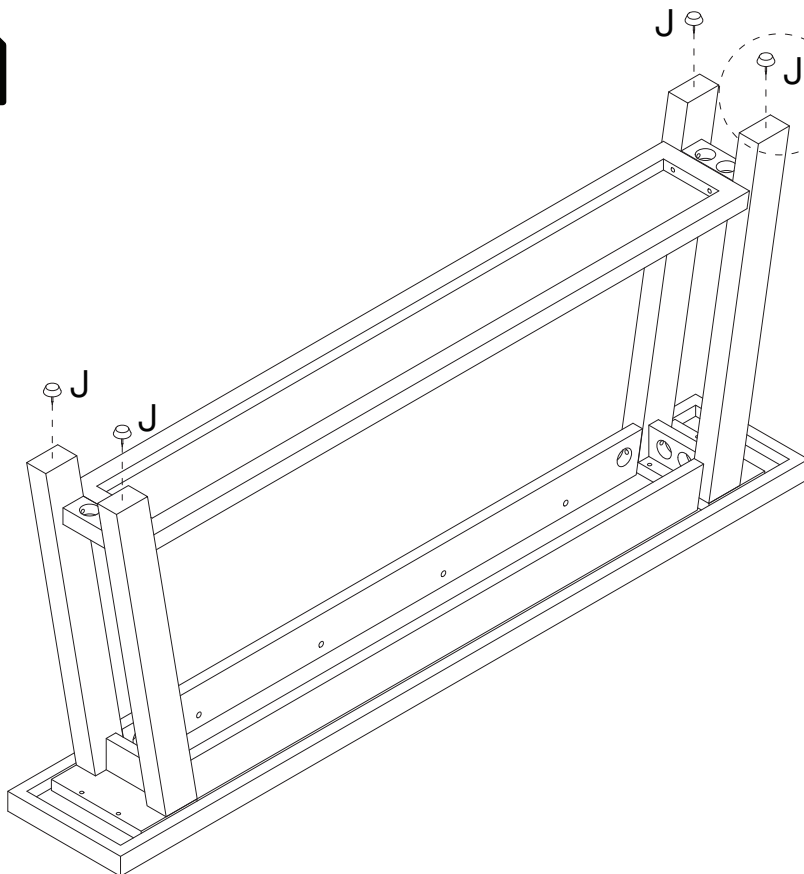

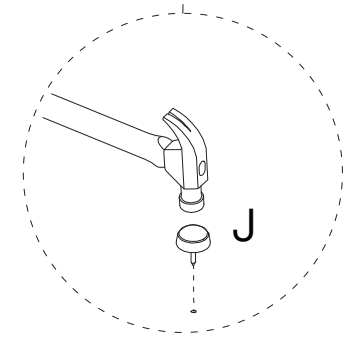

J

4 pcs

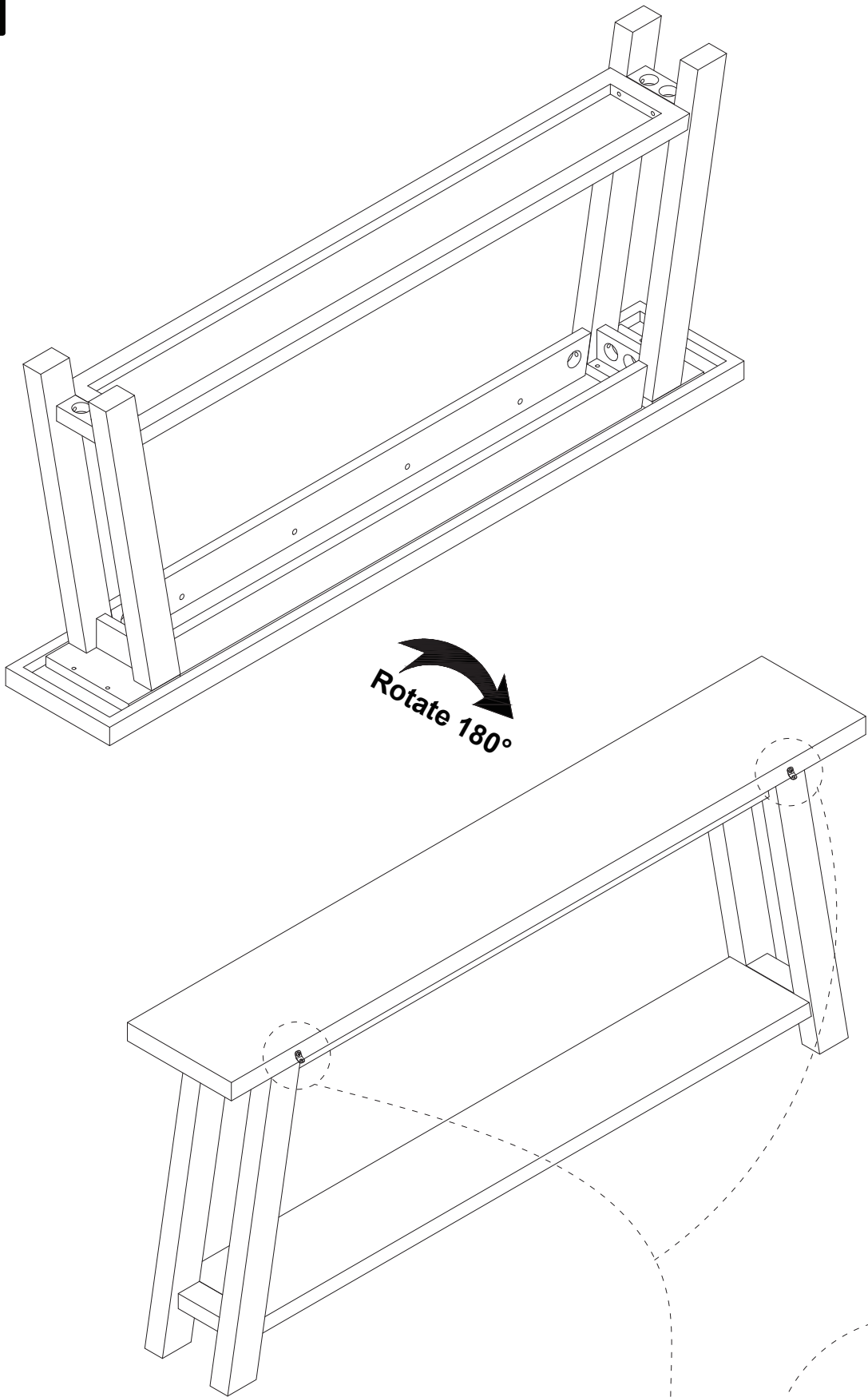

 **Caution! Tap lightly**

9

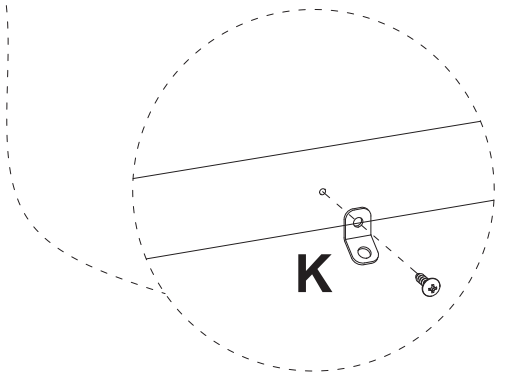

K

2 pcs

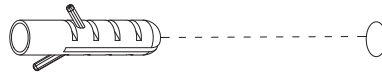

Step1

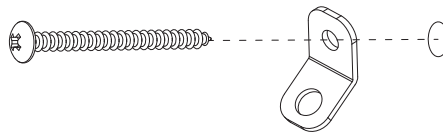

Step2



Step3

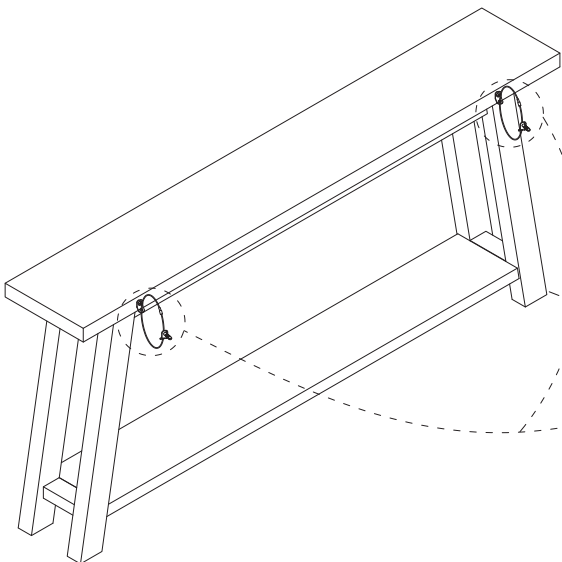
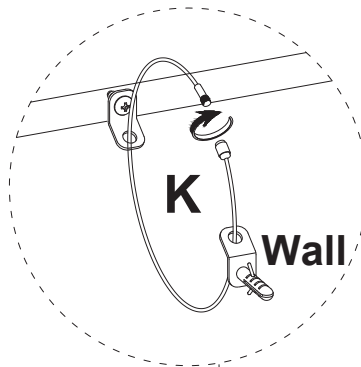

Thank you for your support!

