

# Assembly Instructions

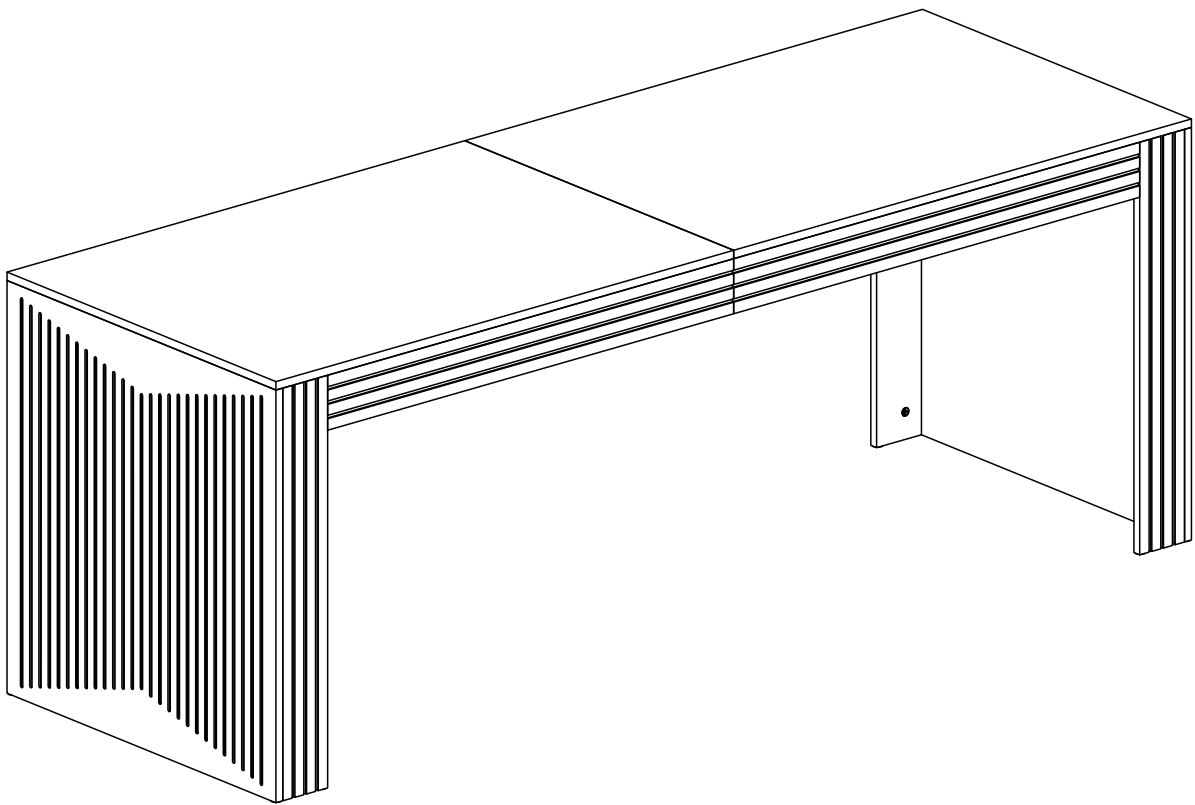

---

**Conference Table**

Model No.  
**HOGA-J0319**  
**HOGA-J0417**

---

# Contact Us

## We're here to help you.

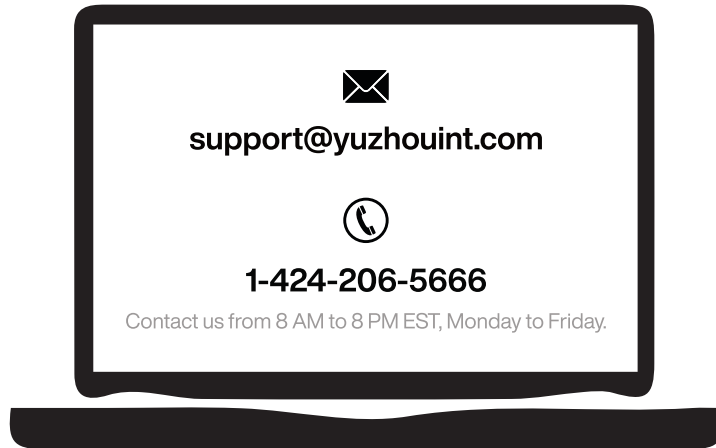

Your satisfaction is our top priority. If you encounter any issues with this product, such as missing or damaged parts, we're here to help. Please retain the original packaging and take photos of the packaging and the product, then contact us as soon as possible.

### Warm Tips

1. Carefully read these instructions and keep them for future reference.
2. Check the parts list and confirm everything's there before starting assembly.
3. When assembling, put all parts on a soft, smooth surface like a carpet to avoid scratches.
4. Don't fully tighten screws until all parts are confirmed in place to avoid misalignment.

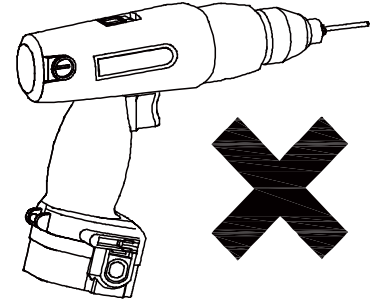
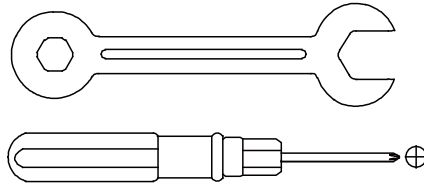
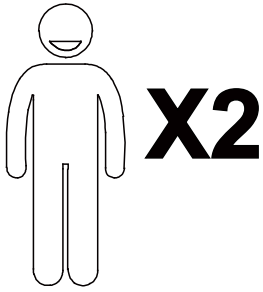

We recommend using hand tools for assembly.

If an electric screwdriver is used, reduce power and torque to avoid damage to the product.

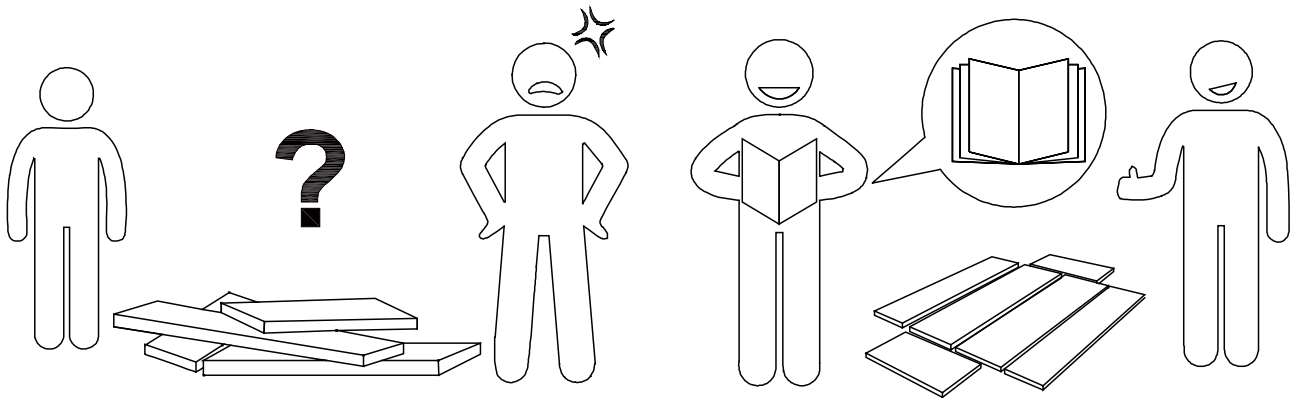

## AVOID SCRATCHES

In order to avoid scratching, this furniture should be assembled on a soft surface, such as a rug.

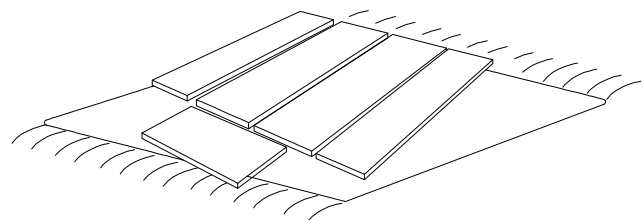
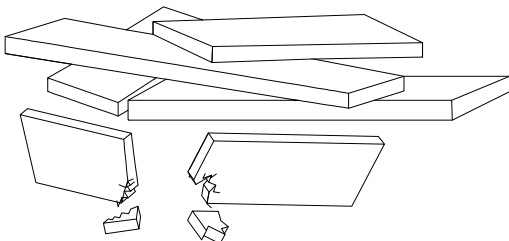

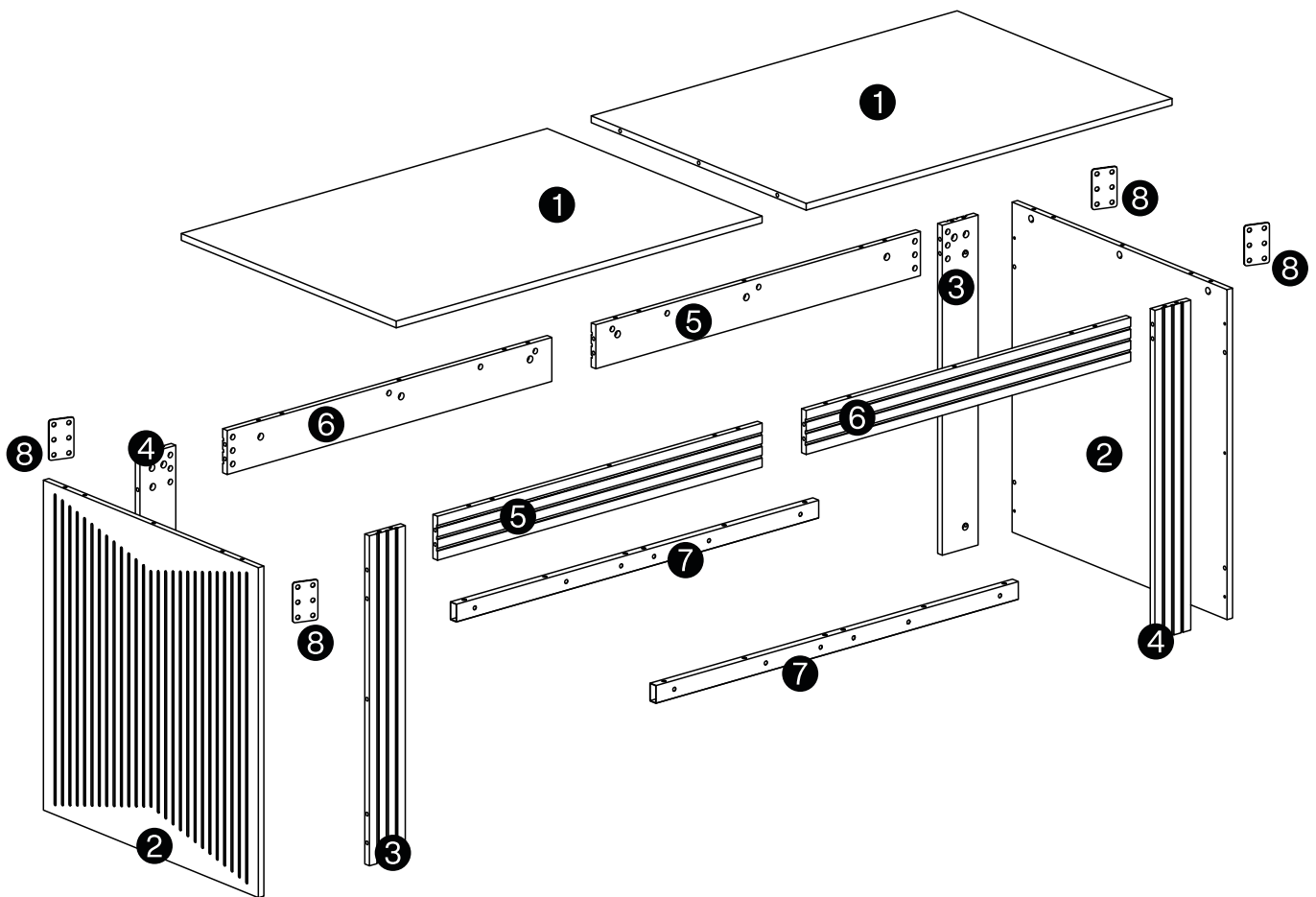



**⚠ Caution**

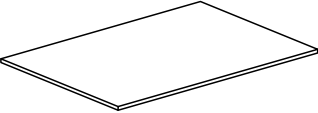
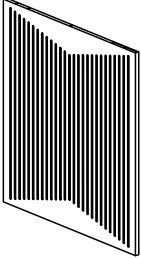
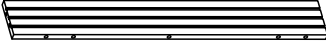
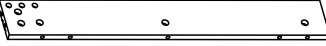
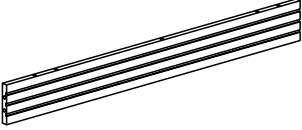
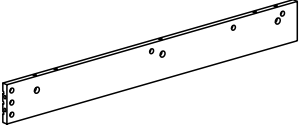
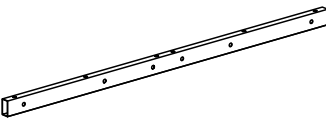
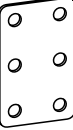

Make sure all parts are included. Most board parts are labeled or stamped on the raw edge. Contact us for a free replacement if you encounter any damaged or missing parts.

## Parts List

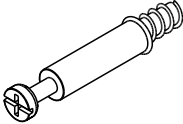
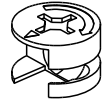
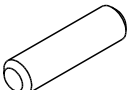
<p><b>1</b></p>  <p>2pcs</p>	<p><b>2</b></p>  <p>2pcs</p>	<p><b>3</b></p>  <p>2pcs</p>	<p><b>4</b></p>  <p>2pcs</p>
<p><b>5</b></p>  <p>2pcs</p>	<p><b>6</b></p>  <p>2pcs</p>	<p><b>7</b></p>  <p>2pcs</p>	<p><b>8</b></p>  <p>4pcs</p>

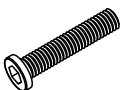
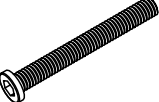
## Hardware List

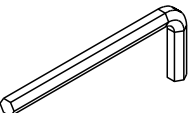
A	B	C	D	E	F
 <p>Ø6x45 mm</p>	 <p>Ø15x12 mm</p>	 <p>Ø8x30 mm</p>	 <p>M6x12 mm</p>	 <p>M6x30 mm</p>	 <p>M6x50 mm</p>
38 pcs + 2 pcs	38 pcs + 2 pcs	35 pcs + 2 pcs	28 pcs + 2 pcs	12 pcs + 1 pc	12 pcs + 1 pc

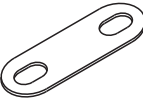
G	H	I
 <p>4 mm</p>		
1 pc	8 pcs	2 pcs

1

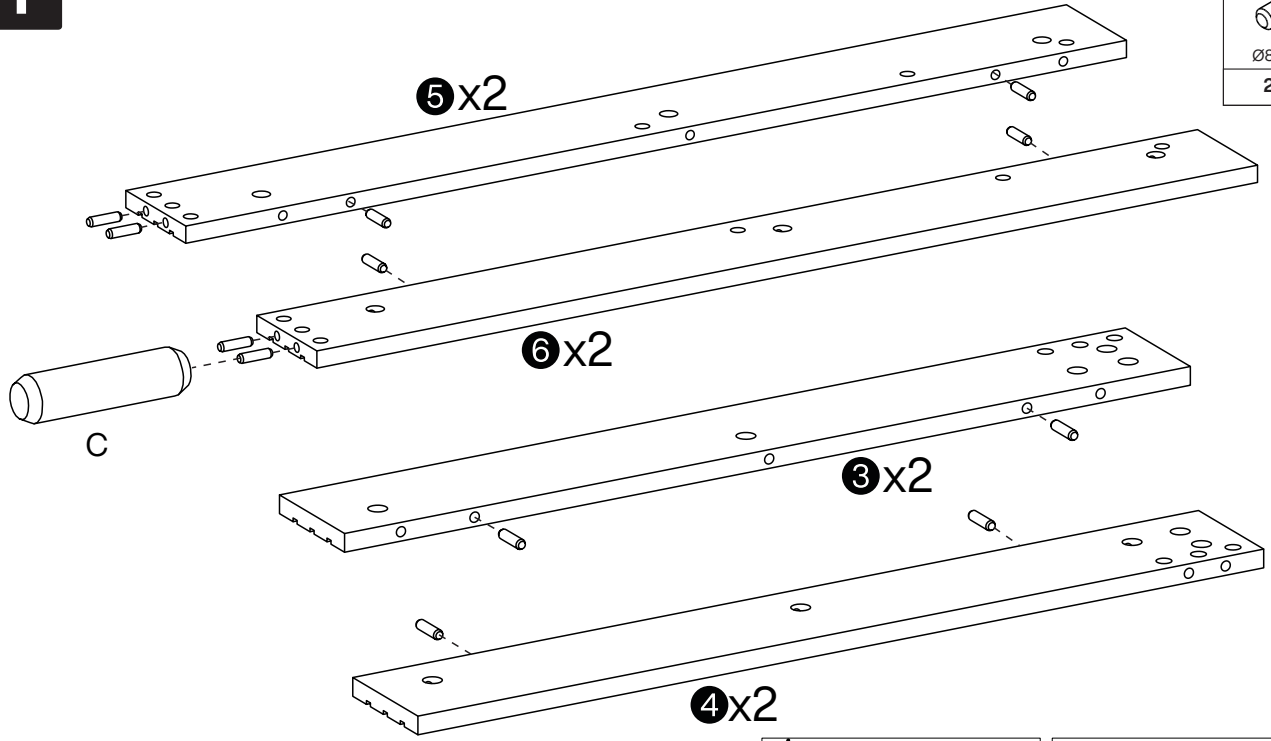

C

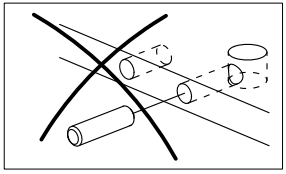
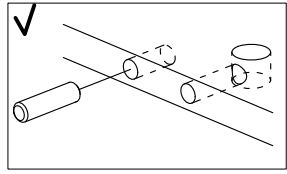
Ø8x30 mm
24 pcs

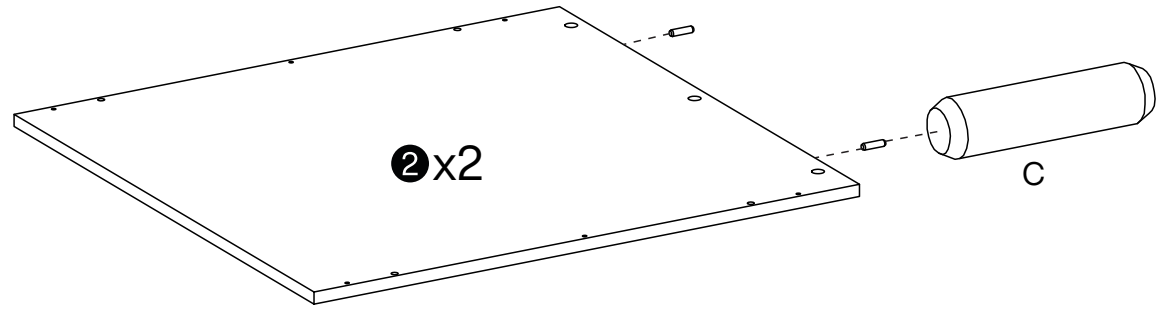

2

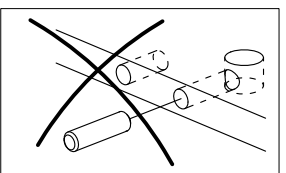
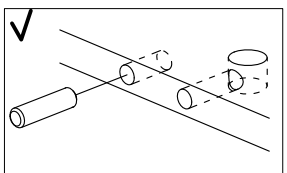

C

Ø8x30 mm
4 pcs

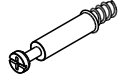

3

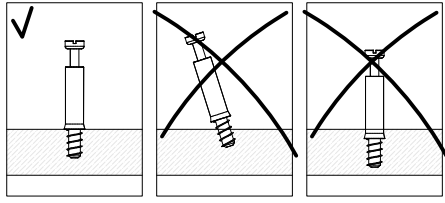
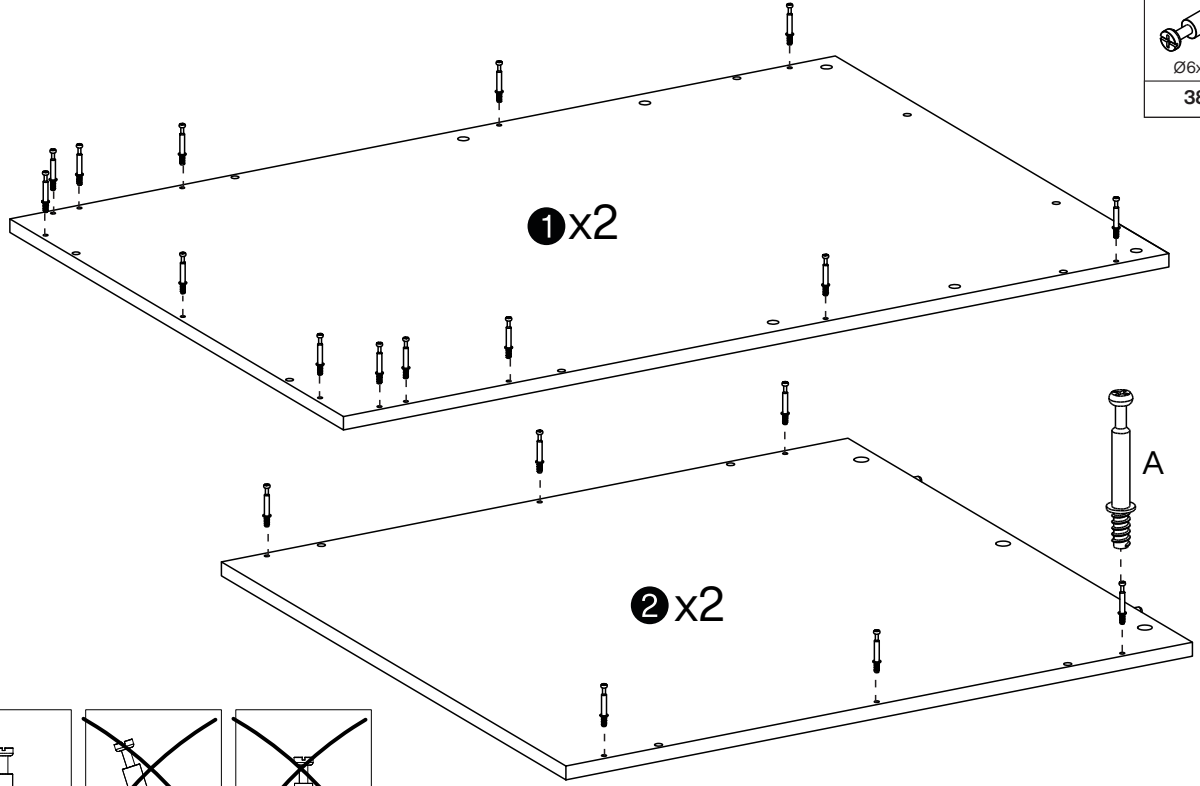
<b>A</b>

Ø6x45 mm
38 pcs

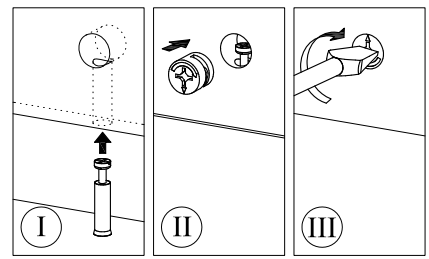
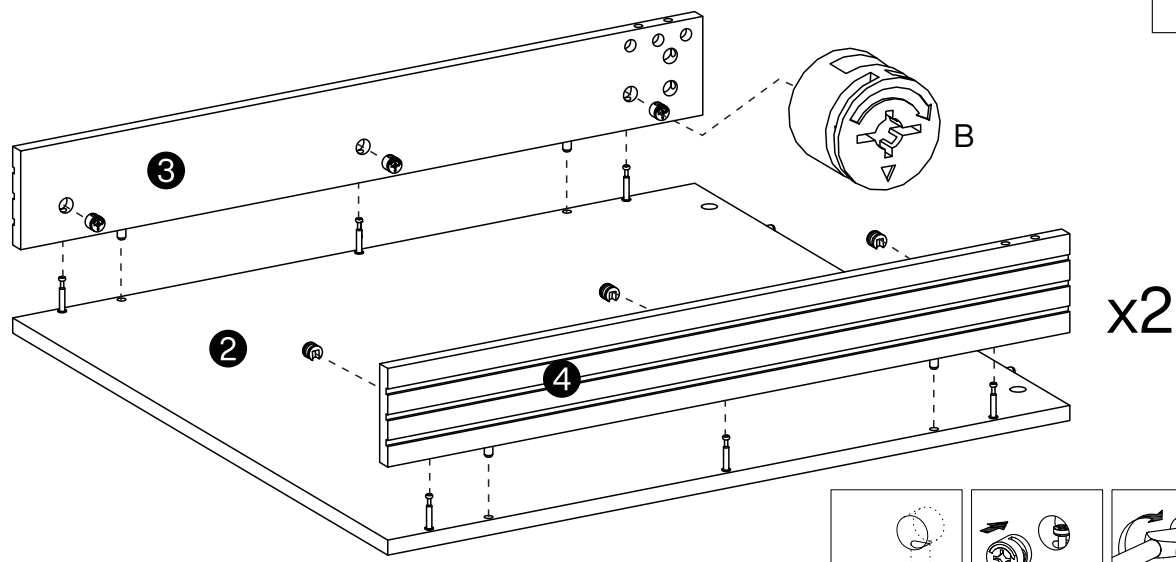

4

<b>B</b>

Ø15x12 mm
12 pcs

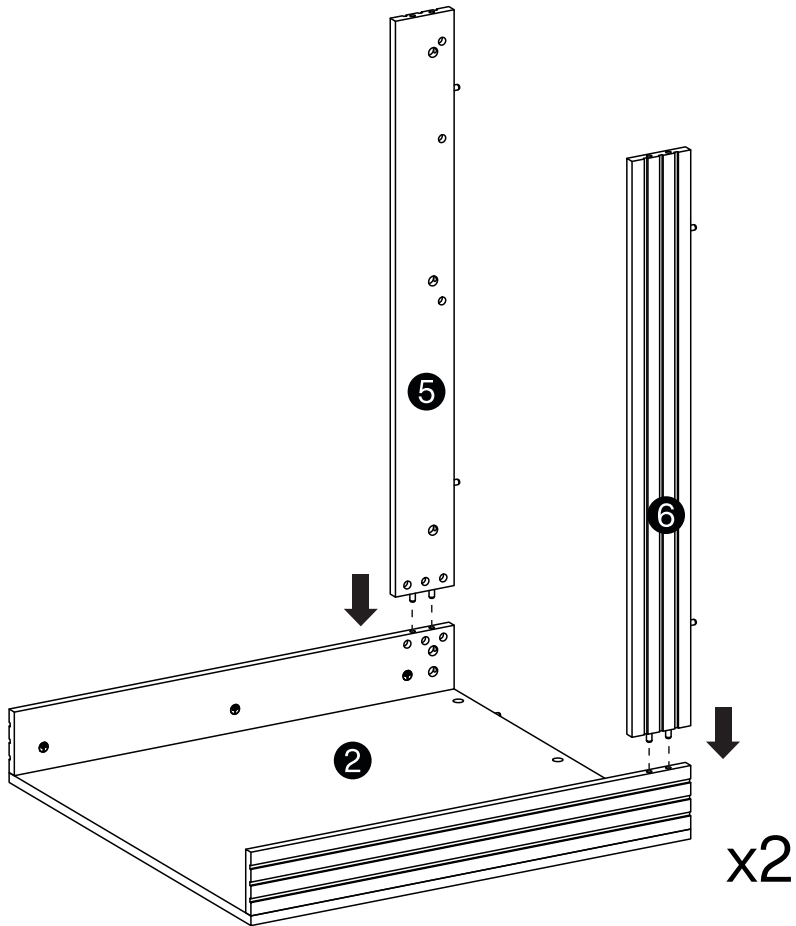

5

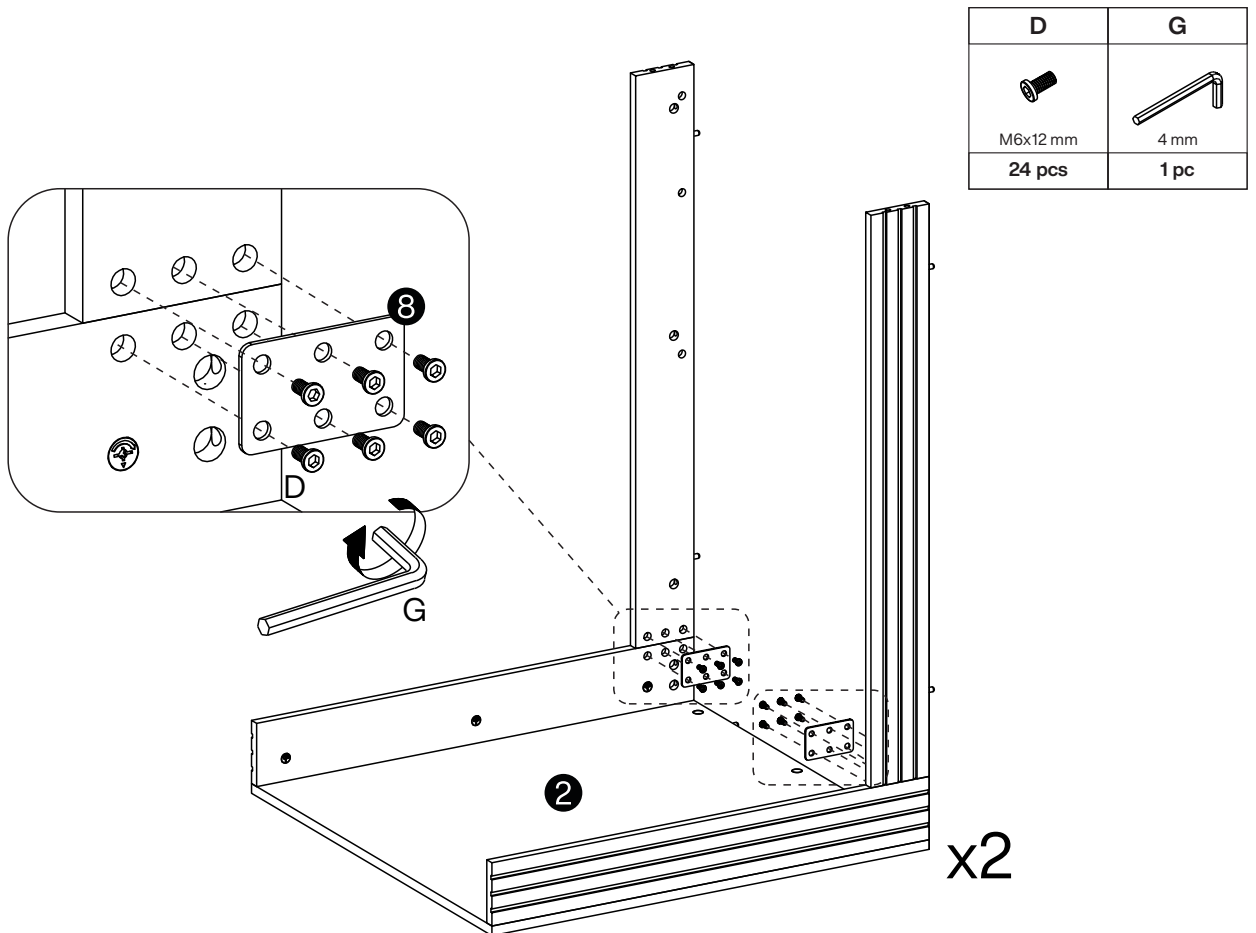

6



7

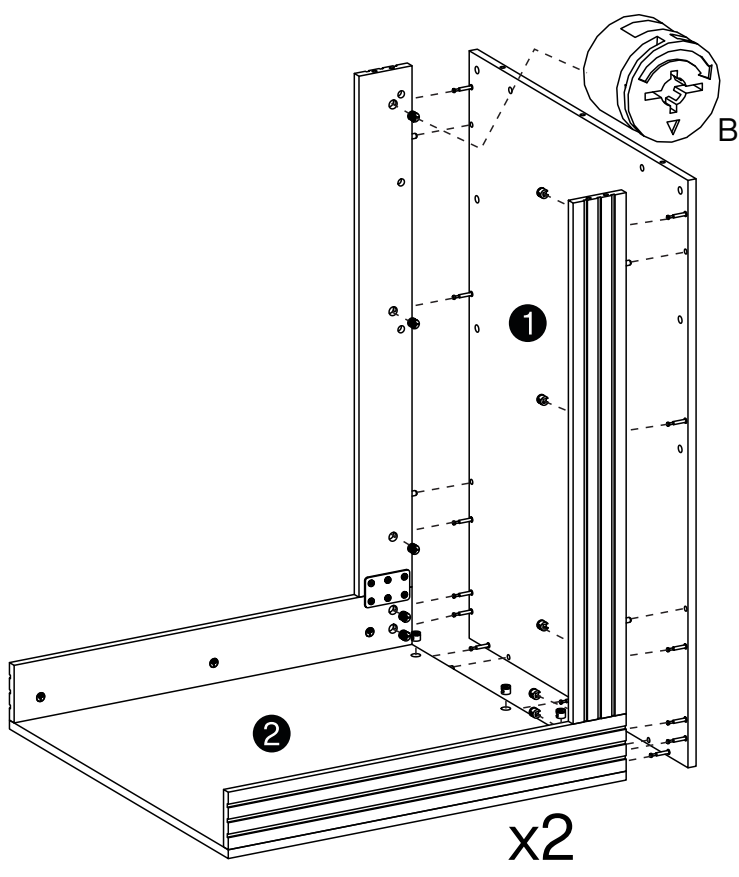

<b>B</b>

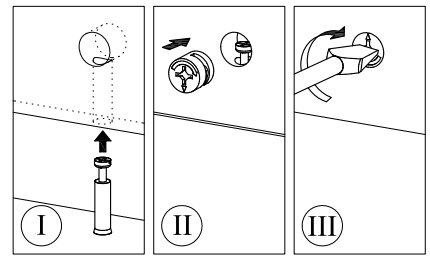
Ø15x12 mm
26 pcs



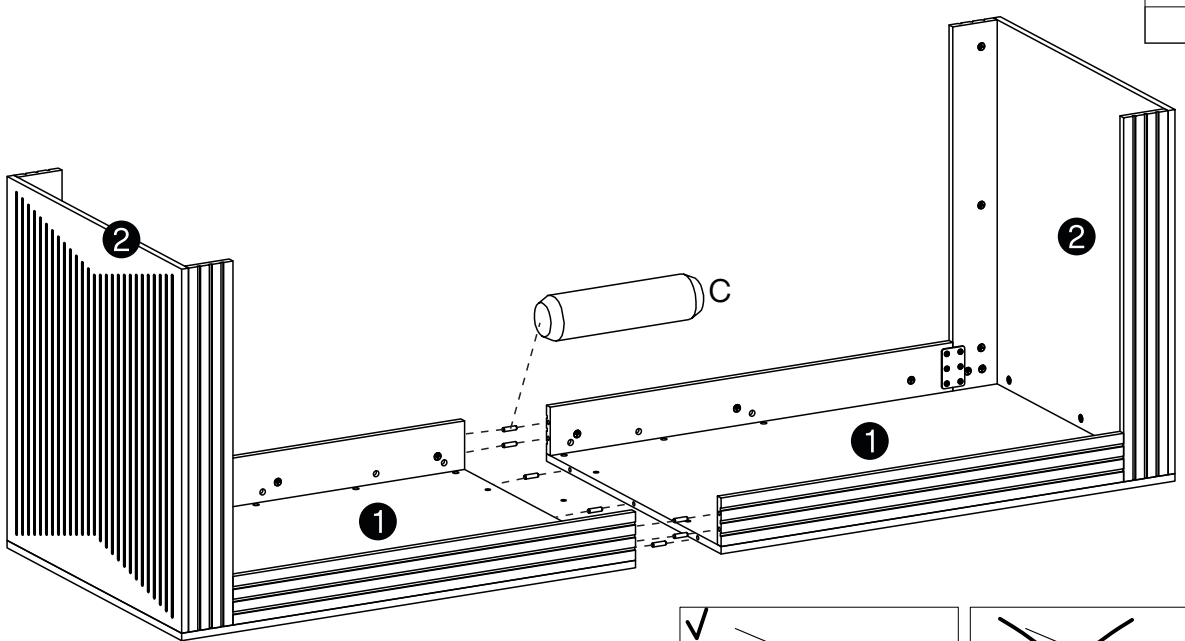

8

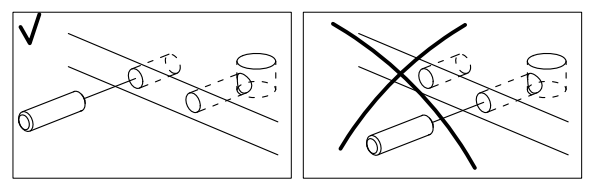

<b>C</b>

Ø8x30 mm
7 pcs



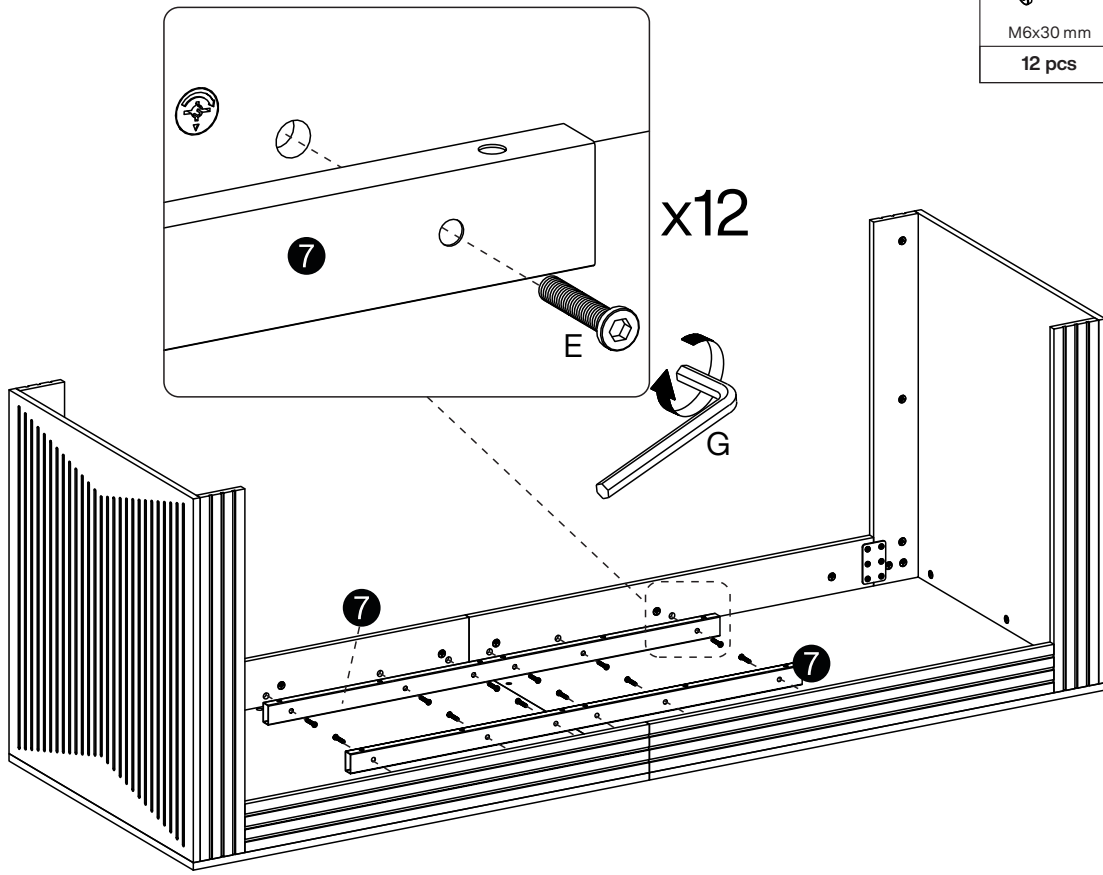

9

E	G
 M6x30 mm	 4 mm
12 pcs	1 pc





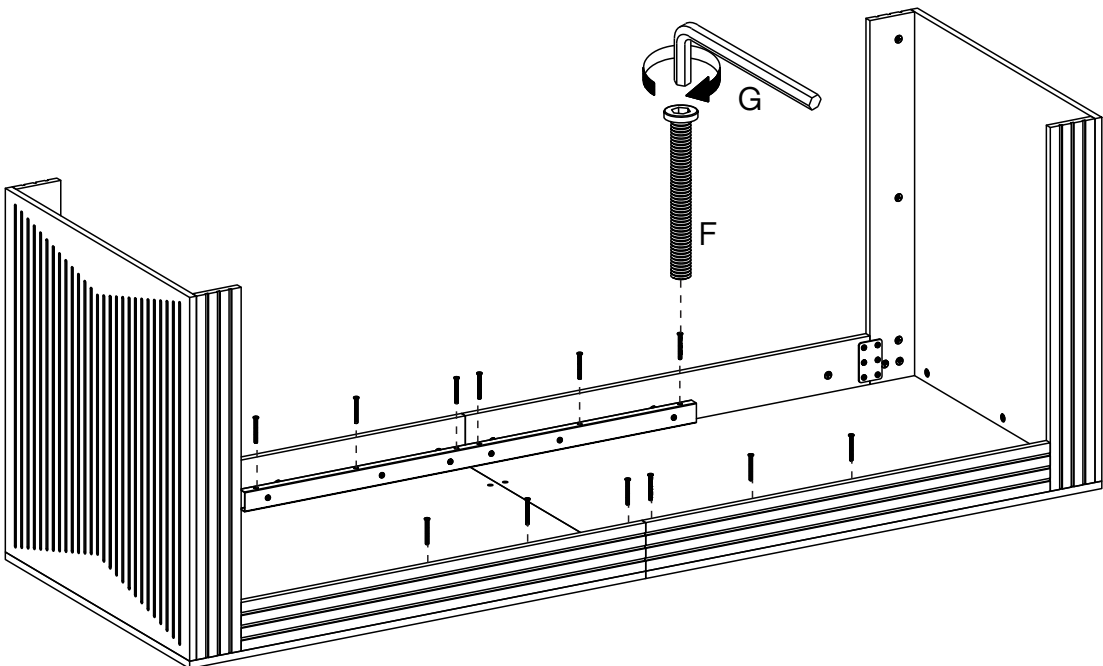

10

F	G
 M6x50 mm	 4 mm
12 pcs	1 pc



11

D	G	H	I
 M6x12 mm	 4 mm		
4 pcs	1 pc	8 pcs	2 pcs

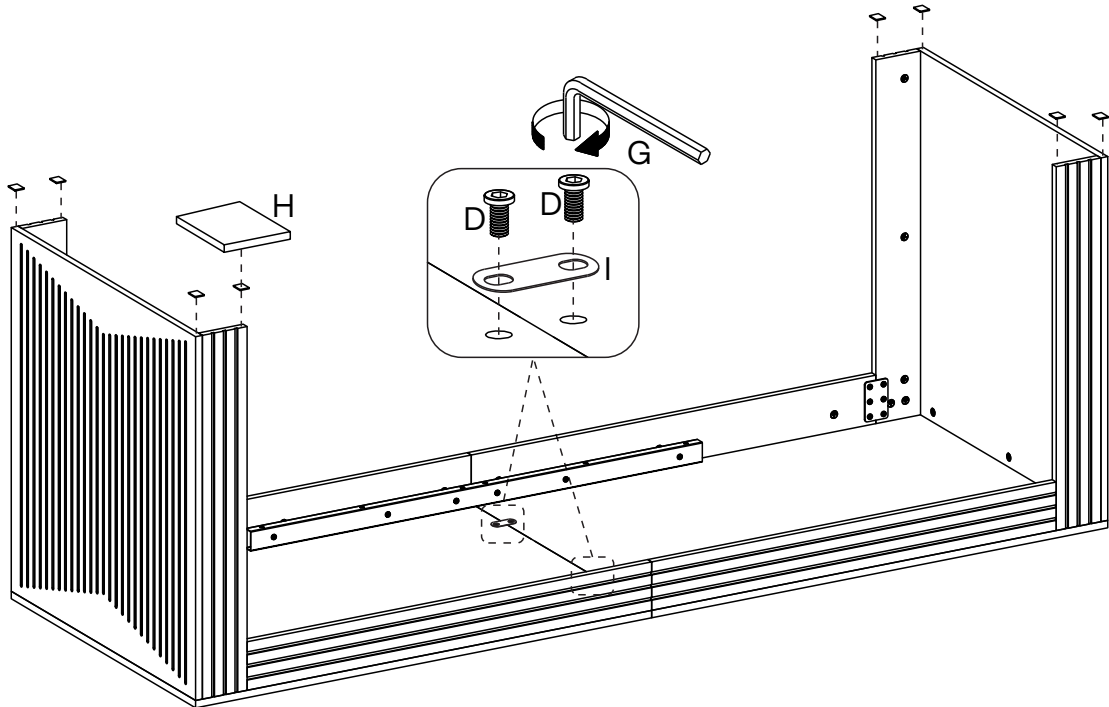

12

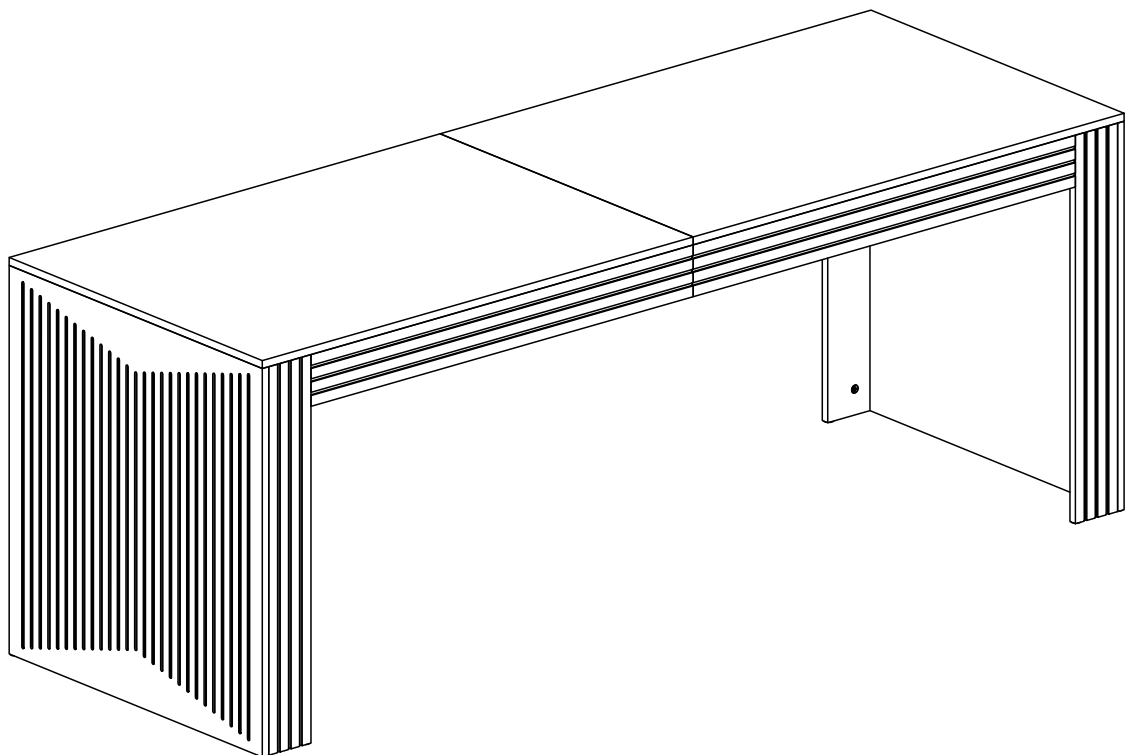

**Thank you for your support!**

